



**Reservedele • Spare parts  
Ersatzteile • Pièces détachées**



**KEW**  
Hobby  
*Hobby X-tra*

"Positionsnummer" der henviser til tegning.  
 "Reference number" which refers to drawing.  
 "Positionsnummer", die auf Zeichnung hinweist.  
 "Numéro de repaires" qui se réfère au plan.

"Produktbetegnelse"  
 "Product designation"  
 "Produktbezeichnung"  
 "Désignation du produit"

Pos. Ref.	Nr. No.	Betegnelse Bezeichnung	Designation Désignation	80 bar	100 bar	120 bar
40	6122652	Rep.kit, skrårskive - 50 Hz Rep.kit, wobble disc Rep.satz, Taumelscheibe Kit de rép., disque oblique	(S)			1
41	6122653	Rep.kit, leje Rep.kit, bearing Rep.satz, Lager Kit de rép., palier		1	1	1
42	6122317	Cylinderblok, komplet Cylinder block, complete Zylinderblock, komplett Bloc-cylindre, complet		x	x	x
43	6123721	Rep.sæt stempel Rep. kit, piston Rep. satz, Kolben Kit de rép., piston		3	3	3
44	3003654	O-ring O-ring O-Ring Joint torique		1	1	1
45	6122313	Prop med O-ring Plug with O-ring Pfropfen mit O-Ring Manchon avec joint torique		2	2	2

"Reparationssæt" indeholder udvalgte reservedele, der er indrammet på tegningen.

"Repair kits" contain selected spare parts, which are boxed in on drawing.

"Reparatursätze" enthalten ausgewählte Ersatzteile, die auf der Zeichnung eingerahmt sind.

"Kit de réparation" contient des pièces détachées sélectionnées, qui sont encadrées sur le plan.

Angiver **antal** dele der indgår i maskinen/hovedkomponenten.

Et "**x**" angiver at artiklen indeholder dele, der også forhandles som løse dele.

States the **number** of parts which form part of the machine/main component.

An "**x**" states that the article contains parts, which are also available as separate parts.

Gibt **Anzahl** Teile an, die im Gerät/in den Hauptkomponenten eingehen.

Ein "**x**" gibt an, daß der Artikel Teile enthält, die auch als Ersatzteile verhandelt werden.

**Nombre** de parts qui font partie du composant primaire.

Une "**x**" dit, que l'article contient des pièces, qui sont aussi vendus séparément.

# KEW Hobby, *Hobby X-tra*

Reservedele • Spare parts  
Ersatzteile • Pièces détachées

## Indholdsfortegnelse Index Inhaltsverzeichnis Sommaire

Side Page Seite Page	Betegnelse Designation Bezeichnung Désignation
4 - 5	Kabinet Cabinet Gehäuse Capot
6 - 7	EI-enhed, Instruktionsbog Electric unit, Instruction manual Elektrische Komponenten, Betriebsanleitung Éléments électriques, Livret d'instructions
8 - 9	Motor, Cylinderblok, Topstykke Motor, Cylinder block, Cylinder head Motor, Zylinderblock, Zylinderkopf Moteur, Bloc-cylindre, Culasse
10 - 11	Omløbsventil, Kabinetbund By-pass valve, Bottom cabinet Umlaufventil, Unterteil des Gehäuses Soupape by-pass, Dessous du capot
12 - 13	Kørevogn Trolley Transportwagen Chariot de transport

Hobby 80/100/120,  
80 X-tra, 100 X-tra, 120 X-tra,  
Special, Basic, Classic

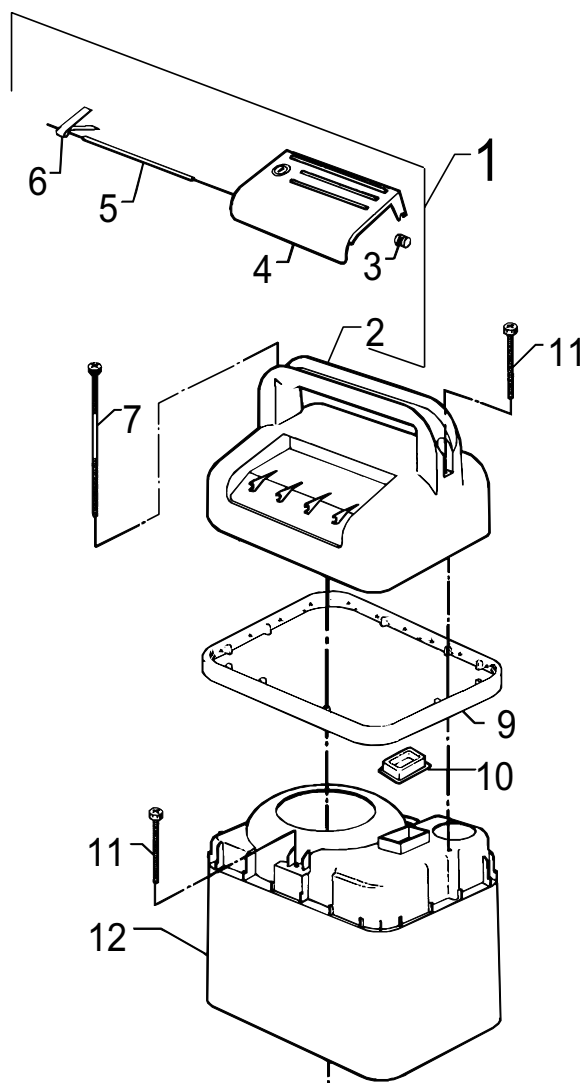

Hobby 1000 / 2000 / 3000  
Hobby 1100 / 2100 / 3100  
X-tra 2500 / X-tra 3500  
X-tra 2600 / X-tra 3600

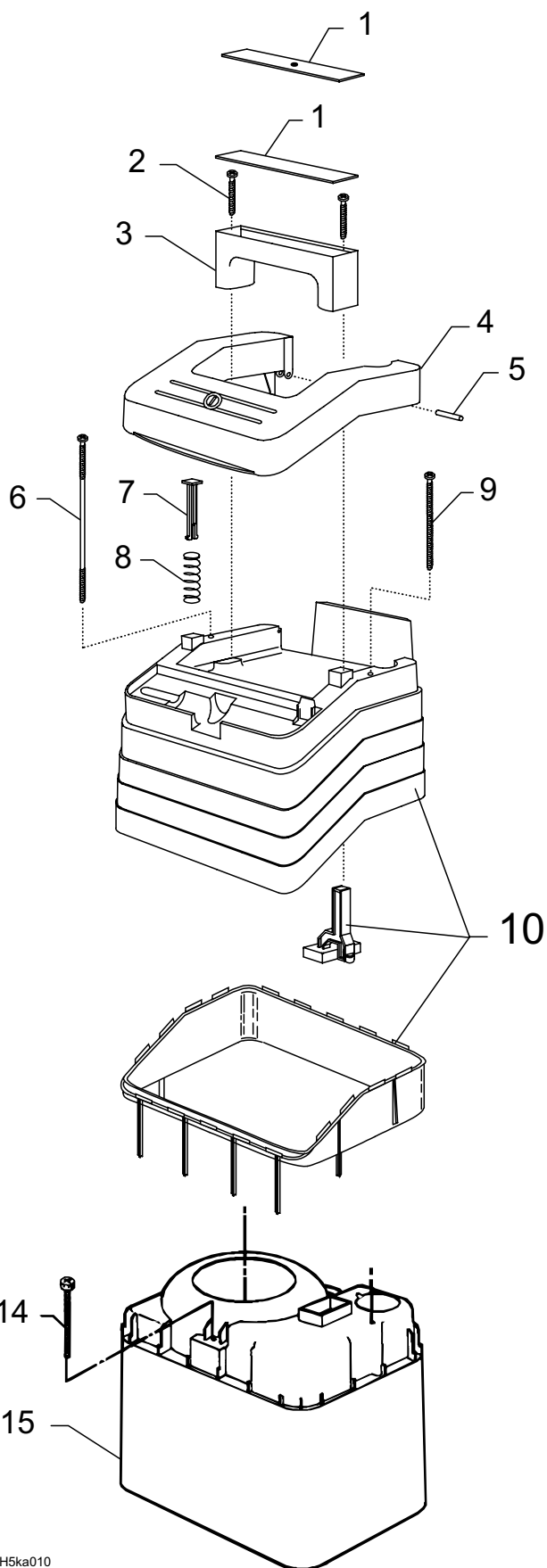

1H5ka010

Pos. Ref.	Nr. No.	Betegnels Bezeichnung	Designation Désignation	80 bar	100 bar	120 bar
1	-	Kabinettop, komplet Top cabinet, compl. Oberteil des Gehäuses, kompl. Dessus du capot, compl.				
-	6122827		80/100/120/Basic/Classic	x	x	x
-	6122843		80 X-tra, 100 X-tra, 120 X-tra	x	x	x
-	6122801		USA/CDN	x		
-	6123709		Special		x	
-	6125546		TopGun		x	
2	-	Kabinettop Top cabinet Oberteil des Gehäuses Dessus du capot				
-	6122725		80/100/120/Basic/Classic	1	1	1
-	6122730		80 X-tra, 100 X-tra, 120 X-tra	1	1	1
-	6122708		USA/CDN	1		
-	6122745		Special		1	
-	6122749		TopGun		1	
3	6122715	Rulle for kontakt Roll for switch Rolle für Schalter Rouleau p. interrupteur		1	1	1
4	6122704	Trykknop Pushbutton Drucktaste Bouton-pression		1	1	1
5	6122713	Aksel Spindle Spindel Arbre		1	1	1
6	6122712	Fjeder Spring Feder Ressort		1	1	1
7	6122522	Skrue Screw Schraube Vis		1	1	1
9	-	Topfender Top fender Toppfender Sommet de amortisseur		1	1	1
-	6122719		80/100/120/Basic/Classic	1	1	1
-	6122732		80/100/120 X-tra	1	1	1
-	6122755		Special		1	
-	6122734		USA/CDN	1		
-	6122759		TopGun		1	
10	6122549	Gummihætte for kabinet Rubber cap for cabinet Gummikappe für Gehäuse Manteau caoutchouc p. capot		1	1	1
11	1809821	Skrue Screw Schraube Vis		3	3	3
12	-	Kabinet, mellemdel Cabinet, intermediate part Kabinett, Zwischenteil Partie intermed., capot				
-	6125535	KEW - blå, blue, blau, bleu		1	1	1
-	6125537	KEW - sort, black, schwarz, noir		1	1	1
-	6125540	KEW - rød, red, rot, rouge			1	
-	6125541	KEW - blue	f. USA/CDN	1		
-	6125538	orange		1		

Pos. Ref.	Nr. No.	Betegnels Bezeichnung	Designation Désignation	80 bar	100 bar	120 bar
1	6128581	Dæksel Cover Deckel Couvercle		1	1	1
-	6523043	Dæksel, s/s Cover, s/s Deckel, S/S Couvercle, m/a			1	1
2	1814276	Skrue Screw Schraube Vis		2	2	2
3	6128578	Håndtag Handle Griff Poignée		1	1	1
-	6523044	Håndtag, s/s Handle, s/s Griff, S/S Poignée, m/a			1	1
4	6122774	Trykknop Pushbutton Drucktaste Bouton-pression		1	1	1
5	1814250	Kærvstift Slotted pin Schlitzstift Goupille à encoches		2	2	2
6	1814300	Skrue Screw Schraube Vis		1	1	1
7	6128585	Fjederarm Arm for spring Arm für Feder Bras pour ressort		1	1	1
8	2602381	Fjeder Spring Feder Ressort		1	1	1
9	1814292	Skrue Screw Schraube Vis		1	1	1
10	6128360	Kabinettop, kompl. Top cabinet, compl. Oberteil des Gehäuses, kompl. Dessus du capot, compl.		1	1	1
-	6125534	Kabinettop, kompl. Top cabinet, compl. Oberteil des Gehäuses, kompl. Dessus du capot, compl.	USA/CDN	1		
-	6523012	Kabinettop f. s/s, kompl. Top cabinet f. s/s, compl. Oberteil des Gehäuses f. S/S, kompl. Dessus du capot p. m/a, compl.			1	1
14	1809821	Skrue Screw Schraube Vis		2	2	2
15	-	Kabinet, mellemdel Cabinet, intermediate part Kabinett, Zwischenteil Partie intermed., capot				
-	6125535	KEW - blå, blue, blau, bleu		1	1	1
-	6125537	KEW - sort, black, schwarz, noir		1	1	1
-	6125541	KEW - blue	f. USA/CDN	1		

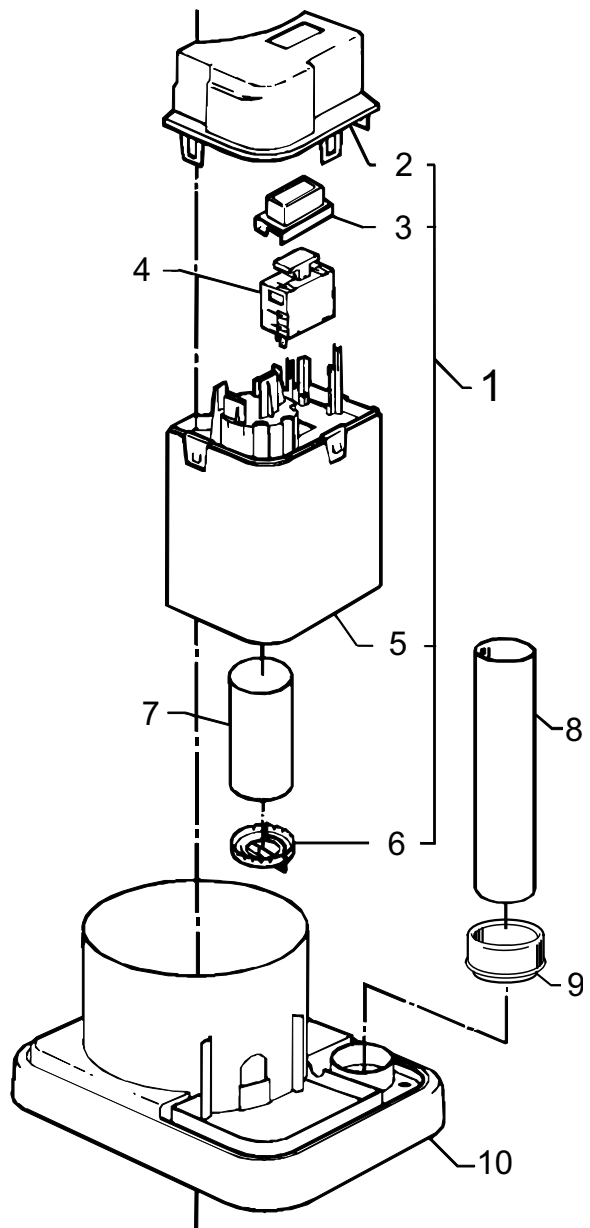
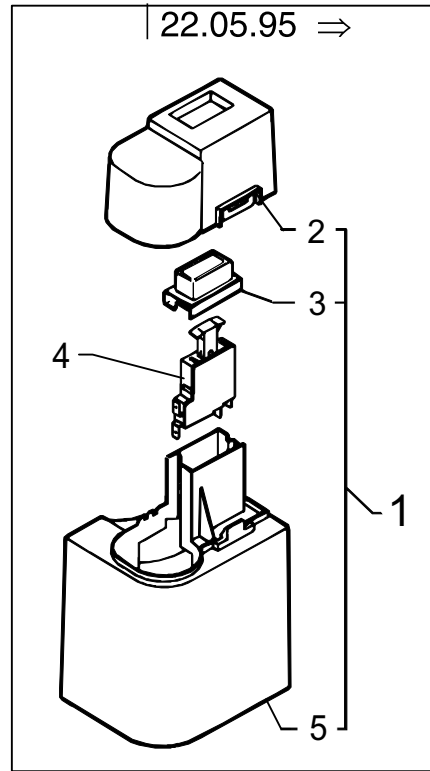
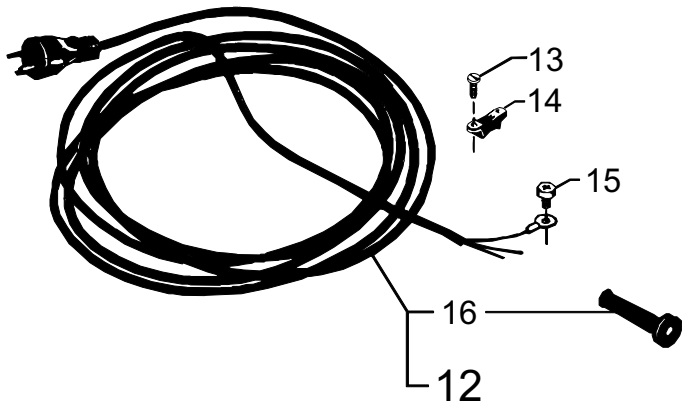
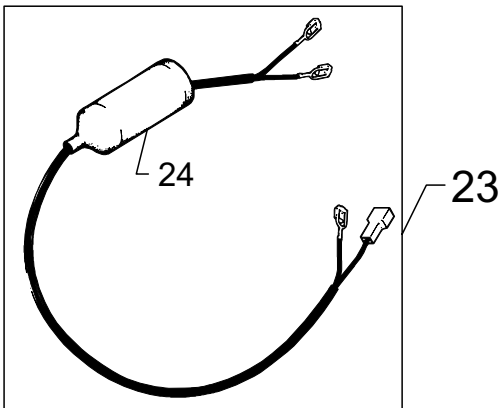
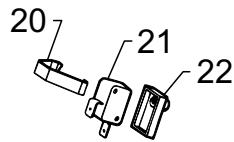
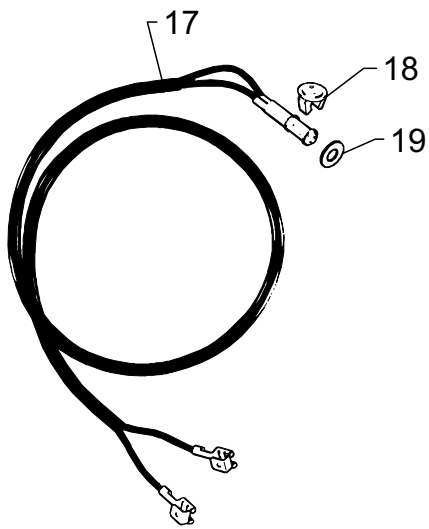

1H3ov000

Pos. Ref.	Nr. No.	Betegnels Bezeichnung	Designation Désignation	80 bar	100 bar	120 bar
1	* 6125548	El-enhed, komplet El. unit, compl. El. Einheit, komplett Unité électrique	22.05.95 ⇒	x	x	x
1	** 6122650	El-enhed, komplet El. unit, compl. El. Einheit, komplett Unité électrique	⇒ 22.05.95   USA, CDN	x	x	x
2	6122153	Top for el-enhed Top for el. unit Oberteil der el. Einheit Dessus de l'unité électrique	22.05.95 ⇒	1	1	1
2	6122108	Top for el-enhed Top for el. unit Oberteil der el. Einheit Dessus de l'unité électrique	⇒ 22.05.95   USA, CDN	1	1	1
3	6122105	Gummihætte Rubber cap Gummikappe Manteau caoutchouc		1	1	1
4	3817004	Trykkontakt, 50 Hz - 9,5 A Pushbutton switch Druckschalter Interrupteur-poussoir	⇒ 22.05.95	1		
4	3819620	Trykkontakt ,50 Hz - 9,8 A Pushbutton switch Druckschalter Interrupteur-poussoir	⇒ 22.05.95		1	1
4	3821346	Trykkontakt, 9,8 A Pushbutton switch Druckschalter Interrupteur-poussoir	22.05.95 ⇒	1	1	1
4	3817012	Trykkontakt Pushbutton switch Druckschalter Interrupteur-poussoir	Hobby 80, USA/CDN 60 Hz - 15 A	1		
5	6122150	Sokkel for el. enhed Socket for el. unit Gestell für el. Einheit Base p. unité électrique	22.05.95 ⇒	1	1	1
5	6122106	Sokkel for el. enhed Socket for el. unit Gestell für el. Einheit Base p. unité électrique	⇒ 22.05.95   USA, CDN	1	1	1
6	6122107	Låseskive Lock washer Federtellerscheibe Circlip	⇒ 22.05.95   USA, CDN	1	1	1
7	3816691	Kondensator Capacitor Kondensator Condensateur	25 µF, 50 Hz	1	1	1
-	3816709	Kondensator Capacitor Kondensator Condensateur	USA/CDN 60 µF, 60 Hz	1		
8	6122710	Rør Tube Rohr Tube		1	1	1
9	6122584	Gummitætning for rør Rubberseal f. tube Gummidichtung f. Rohr Support caoutchouc p. tube		1	1	1
10	6122703	Kabinettfender Cabinet fender Gehäusefender Amortisseur capot		1	1	1

Pos. Ref.	Nr. No.	Betegnels Bezeichnung	Designation Désignation	80 bar	100 bar	120 bar
12	-	El-kabel med stik El. cable with plug Anschlusskabel mit Stecker Câble électrique + prise				
-	6128155	HO7RN-F 3G 1.0, DK		1	1	1
-	6122202	HO7RN-F 3G 1.0/TDV 3G 1.0, CH		1	1	1
-	6122246	HO7RN-F 3G 1.0, I		1	1	1
-	6122204	HO5VV-F 3G 1.0, GB, SGP		1	1	1
-	6122205	SJTOW-A AVG 14/3, USA		1		
-	6122206	SJOW AVG 14/3, CDN,CN,ROK		1		
-	6122207	HO5VV-F, AUS, NZ		1	1	
-	6122210	HO5VV-F 3G 10, HK		1	1	
-	6122211	HO7RN-F 3G 1.0 D,A,F,N,S,B,NL,P,E,GR,IL,SF,CSSR		1	1	1
13	6122531	Skrue Screw Schraube Vis		2	2	2
14	3806262	Trækafastning Cable lead-in Zugentlastung Dispositif d'attaque auxil.		1	1	1
15	1809847	Jordskrue Earth screw Erdschraube Bloque câble		1	1	1
16	6122101	Gummitülle Rubber bush Gummitülle Douille p. câble, caoutchouc		1	1	1
17	6522758	Lampeledning , s/s Cable f. light indicator, s/s Lampekabel, S/S Câble p.lampe, m/a			1	1
18	6522788	Lampeglass, s/s Glass f. light indicator, s/s Lampenglas, S/S Verre de témoin lumineux, m/a			1	1
19	6522767	Pakning for ledning, s/s Gasket f. cable, s/s Dichtung f. Kabel, S/S Joint p. câble, m/a			1	1
20	6522759	Bøjle for kontakt, s/s Bracket for switch, s/s Bügel für Schalter, S/S Garniture p. contacteur, m/a			1	1
21	3821510	Kontakt, s/s Micro switch, s/s Schalter, S/S Contacteur, m/a			1	1
22	6522765	Kontaktfixtur, s/s Fixture f. switch, s/s Schalterfixtur, S/S Fixation p. contacteur, m/a			1	1
23	3821394	Mellemedning f. s/s, kompl. Interconnecting cable f. s/s, compl. Zwischenkabel f. S/S, kompl. Câble de connection p. m/a, compl.			1	1
24	6523047	Gummitülle Rubber bush Gummitülle Douille p. câble, caoutchouc			1	1
-	-	Instruktionsbog Instruction manual Betriebsanweisung Livret d'instructions				
-	6129804	DK, GB, D, F, N, S, NL, SF, E, I, GR, P 1100, 2100, 3100, X-tra 2600 - 3600		1	1	1
-	6129809	DK, GB, D, F, N, S, NL, SF, E, I, GR, P TopGun, Special, Classic			1	
-	6129312	DK, GB, D, F, N, S, NL, SF, E, I 80/100/120 Hobby, Basic, X-tra, 100 Special		1	1	1
-	6128995	DK, GB, D, F, N, S, NL, SF, E, I, GR, P 1000, 2000, 3000, X-tra 2500, X-tra 3500		1	1	1
-	6129265	US		80	1	
-	6128998	US		1000	1	

598 61 00 - 00.11

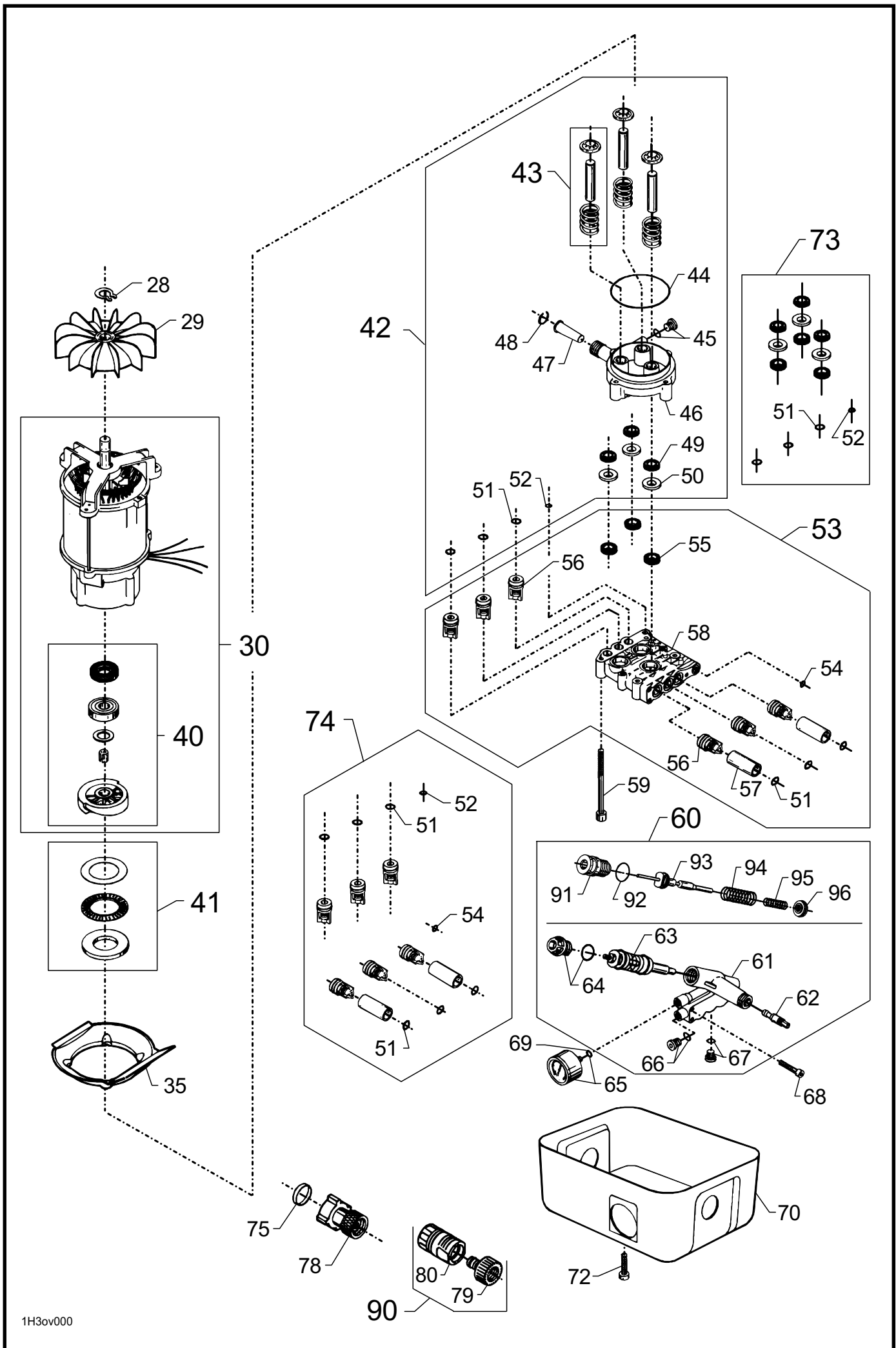

1H3ov000



Pos. Ref.	Nr. No.	Betegnels Bezeichnung	Designation Désignation	80 bar	100 bar	120 bar
28	1809839	Låsering Circlip Schliessring Circlip		1	1	1
29	6122476	Ventilator Fan Ventilator Ventilateur		1	1	1
30	-	<b>Motor m. skråskive, komplet</b> <b>Motor w. wobble disc, complete</b> <b>Motor m. Taumelscheibe, komplett</b> <b>Moteur avec disque obl., compl.</b>				
-	6122322	230V, 50 Hz f. <b>A,B,CH,D,DK,E,F,GR,HK,I,IL,IS</b> <b>N,NL,P,S,SF,SGP,ZA,CSSR</b>	(R)	x		
-	6122325	230V, 50 Hz f. <b>A,B,CH,D,DK,E,F,GR,HK,I,IL,IS</b> <b>N,NL,P,S,SF,SGP,ZA,CSSR</b>	(T)		x	
-	6123678	230V, 50 Hz f. <b>A,B,CH,D,DK,E,F,GR,HK,I,IL,IS</b> <b>N,NL,P,S,SF,SGP,ZA,CSSR</b>	(S)			x
-	6125554	230V, 50 Hz (Hobby 3100 - 3499 / 3520 - 3999 / Power)	(F)			x
-	6122322	240V, 50 Hz f. <b>GB,AUS,NZ</b>	(R)	x		
-	6122326	240V, 50 Hz f. <b>GB,AUS,NZ</b>	(T)		x	
-	6123679	240V, 50 Hz f. <b>GB,AUS,NZ</b>	(S)			x
-	6125555	240V, 50 Hz (Hobby 3100 - 3499 / 3520 - 3999 / Power)	(F)			x
-	6122324	115V, 60 Hz f. <b>USA,CDN,CN,ROK</b>	(S)	x		
35	6122727	Skørt Shirt Schürze Jupon		1	1	1
40	-	<b>Rep.kit, skråskive - 50 Hz</b> <b>Rep.kit, wobble disc</b> <b>Rep.satz, Taumelscheibe</b> <b>Kit de rép., disque oblique</b>				
.	6122651	230V, 50Hz - 240V, 50Hz	(R)	1		
-	6122652	115V, 60Hz - 240V, 50Hz	(S)	1		1
-	6122662	230V, 50Hz - 240V, 50Hz	(T)		1	
-	6123681	230V, 50Hz - 240V, 50Hz (Hobby 3100 - 3499 / 3520 - 3999 / Power)	(F)			1
41	6122653	<b>Rep.kit, leje</b> <b>Rep.kit, bearing</b> <b>Rep.satz, Lager</b> <b>Kit de rép., palier</b>		1	1	1
42	6122317	<b>Cylinderblok, komplet</b> <b>Cylinder block, complete</b> <b>Zylinderblock, komplett</b> <b>Bloc-cylindre, complet</b>		x	x	x

Pos. Ref.	Nr. No.	Betegnels Bezeichnung	Designation Désignation	80 bar	100 bar	120 bar
43	6123721	<b>Rep.sæt stempel</b> <b>Rep. kit, piston</b> <b>Rep. satz, Kolben</b> <b>Kit de rép., piston</b>		3	3	3
44	3003654	O-ring O-ring O-Ring Joint torique		1	1	1
45	6122313	Prop med O-ring Plug with O-ring Pfropfen mit O-Ring Manchon avec joint torique		2	2	2
46	7181005	Cylinderblok Cylinder block Zylinderblock Bloc-cylindre		1	1	1
47	6125144	Filter Filter Filter Filtre		1	1	1
48	1807833	Springring Spring ring Klemmring Anneau à ressort		1	1	1
49	3003696	Oliemanchet Oil sleeve Ölmanschette Rondelle d'huile		3	3	3
50	6122486	Trykring Thrust collar Druckring Anneau de blocage		3	3	3
51	3004222	O-ring O-ring O-Ring Joint torique		6	6	6
52	3001823	O-ring O-ring O-Ring Joint torique		1	1	1
53	6122319	<b>Topstykke, komplet</b> <b>Cylinder head, complete</b> <b>Zylinderkopf, komplett</b> <b>Culasse, compléte</b>		x	x	x
54	3003688	O-ring O-ring O-Ring Joint torique		1	1	1
55	3001914	U-manchet U-sleeve U-Manschette Joint U		3	3	3
56	6122318	Ventil, komplet Valve, complete Ventil, komplett Clapet, compl.		6	6	6
57	6122475	Afstandsstykke Spacer Zwischenstück Pièce d'espace		2	2	2
58	6124243	Topstykke Cylinder head Zylinderkopf Culasse		1	1	1
59	1809862	Skruer Screw Schraube Vis		4	4	4

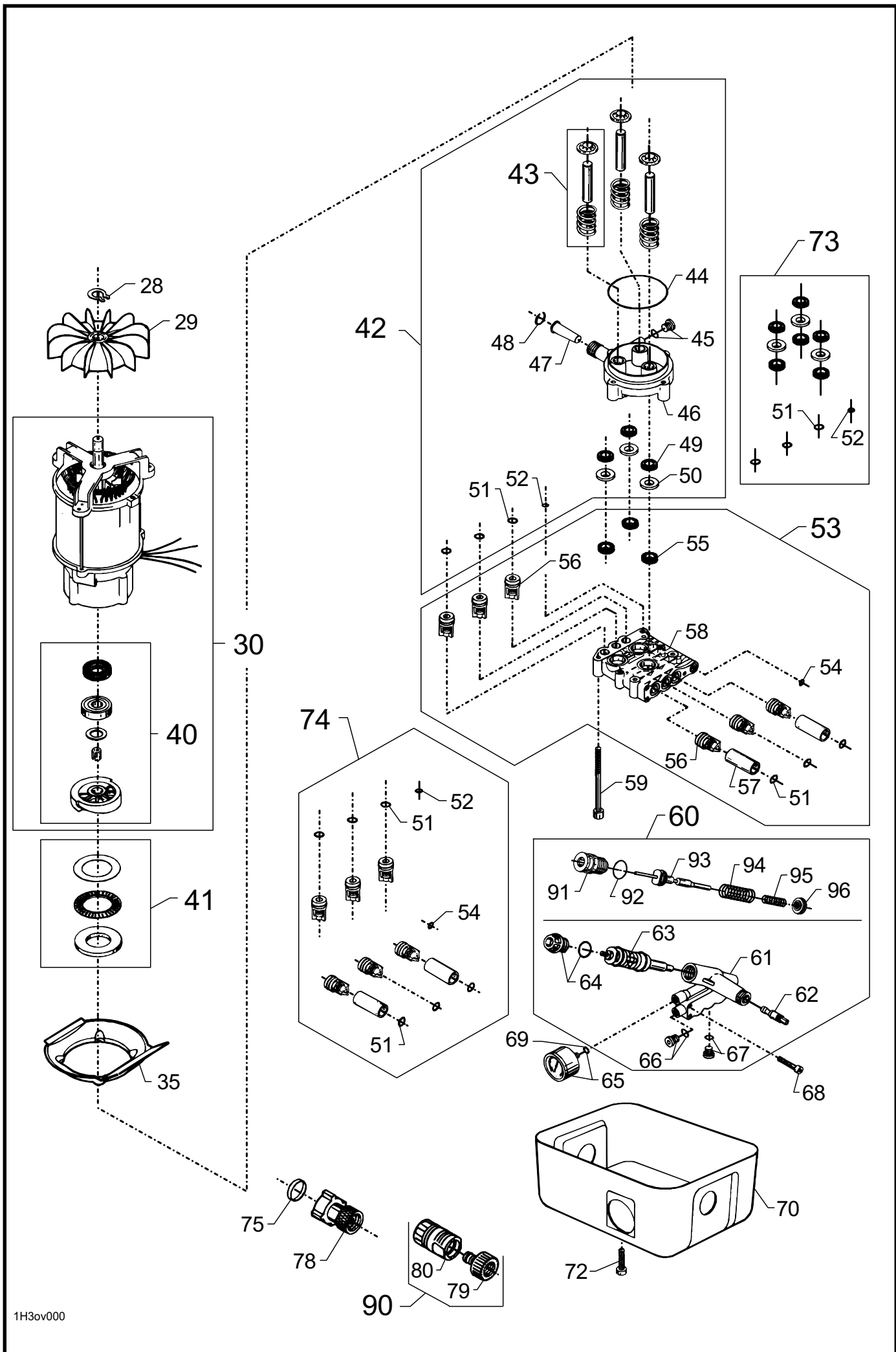

1H3ov000

Pos. Ref.	Nr. No.	Betegnelse Bezeichnung	Designation Désignation	80 bar	100 bar	120 bar
60	-	Omløbsventil, komplet By-pass valve, complete Umlaufventil, komplett Soupape by-pass, compl.				
-	6122320	80 bar		x		
-	6122364	100 bar			x	
-	6123656	120 bar				x
-	6128344	(Hobby 3100 - 3499 / 3520 - 3999 / Power)				x
60	-	Omløbsventil f. s/s, komplet By-pass valve f. s/s, complete Umlaufventil f. S/S, komplett Soupape by-pass p. m/a, compl.				
-	6523010	100 bar			x	
-	6523011	120 bar				x
61	6122536	Ventilhus Valve housing Ventilgehäuse Boîte de soupape		1	1	1
62	-	Styredyse Steering nozzle Steuerdüse Buse de guidage				
-	6122314	hvid/white/weiß/blanc	80 bar	1		
-	6122365	grøn/green/grün/vert	100 bar		1	
-	6123658	orange	120 bar			1
-	6124311	blå/bleu/blau/bleu (Hobby 3100 - 3499 / 3520 - 3999 / Power)				1
63	6122311	Ventilkegle, komplet Valve cone, complete Ventilkegel, komplett Cône p. clapet, compl.	80 & 100 bar	1	1	
-	6123657	Ventilkegle, komplet Valve cone, complete Ventilkegel, komplett Cône p. clapet, compl.	120 bar			1
64	6122312	Prop med O-ring Plug with O-ring Pfropfen mit O-Ring Manchon avec joint torique	80 & 100 bar	1	1	
-	6123654	Prop med O-ring Plug with O-ring (aluminium) Pfropfen mit O-Ring Manchon avec joint torique	120 bar			1
65	6122315	Manometer med O-ring Pressure gauge with O-ring Manometer mit O-Ring Manomètre avec joint torique		1	1	1
-	3003662	O-ring for manometer O-ring for pressure gauge O-ring für Manometer Joint torique p. manomètre		1	1	1
66	6123655	Prop med O-ring Plug with O-ring Pfropfen mit O-Ring Manchon avec joint torique		1	1	1
-	6125549	Prop med O-ring Plug with O-ring Pfropfen mit O-Ring Manchon avec joint torique	TopGun		1	
67	6123655	Prop med O-ring Plug with O-ring Pfropfen mit O-Ring Manchon avec joint torique		1	1	1
68	1810092	Skrue Screw, M6x30 Schraube Vis	80 & 100 bar ⇒ 01.04.93	3	3	
-	1814573	Skrue Screw, M6x35 Schraube Vis	120 bar 80 & 100 bar 01.04.93 ⇒	3	3	3

Pos. Ref.	Nr. No.	Betegnelse Bezeichnung	Designation Désignation	80 bar	100 bar	120 bar
70	6122352	Kabinetbund, komplet Bottom cabinet, complete Unterteil des Gehäuses, kompl. Dessous du capot, compl.		x	x	x
72	1809896	Skrue Screw Schraube Vis		2	2	2
73	6123720	Rep.kit, tætningssystem Rep.kit, sealing system Rep.satz, Dichtungssystem Kit de rép., système d'étanchéité		x	x	x
74	6122655	Rep.kit, ventilsystem Rep.kit, valve system Rep.satz, Ventilsystem Kit de rép., clapet		x	x	x
75	3002128	Pakning Gasket Dichtung Joint	USA/CDN	x		
78	1605948	Skruekobling, komplet Screw coupling, complete Schraubekupplung, komplett Raccord visse, compl.	USA/CDN	x		
79	1402809	Lynkoblingsnippel Quick coupling, nipple Schnellkupplung, Nippel Raccord rapide, entrée	Hobby/X-tra	1	1	1
80	1608629	Lynkobling Quick coupling Schnellkupplung Raccord rapide mâle	X-tra	1	1	1
90	6410056	Lynkobling, komplet Quick coupling, compl. Schnellkupplung, komplett Raccord rapide, compl.	X-tra	x	x	x
91	6523000	Pakdåse, kompl. Stuffing box, compl. Stopfbuchse, kompl. Presse-étoupe, compl.			1	1
92	3004245	O-ring O-ring O-Ring Joint torique			1	1
93	6523001	Stempel f. s/s, kompl. Piston f. s/s, compl. Kolben f. S/S, kompl. Piston p. m/a, compl.			1	1
94	2602431	Fjeder, stor Spring, big Feder, gros Ressort, gros		1	1	
95	2602449	Fjeder, lille Spring, small Feder, klein Ressort, petit		1	1	
96	6523002	Sæde f. s/s, kompl. Seat f. s/s, compl. Sitz f. s/s, kompl. Siège p. m/a, compl.			1	1
-	5301425	KEW Pump Oil 46, 1x1 l		x	x	x

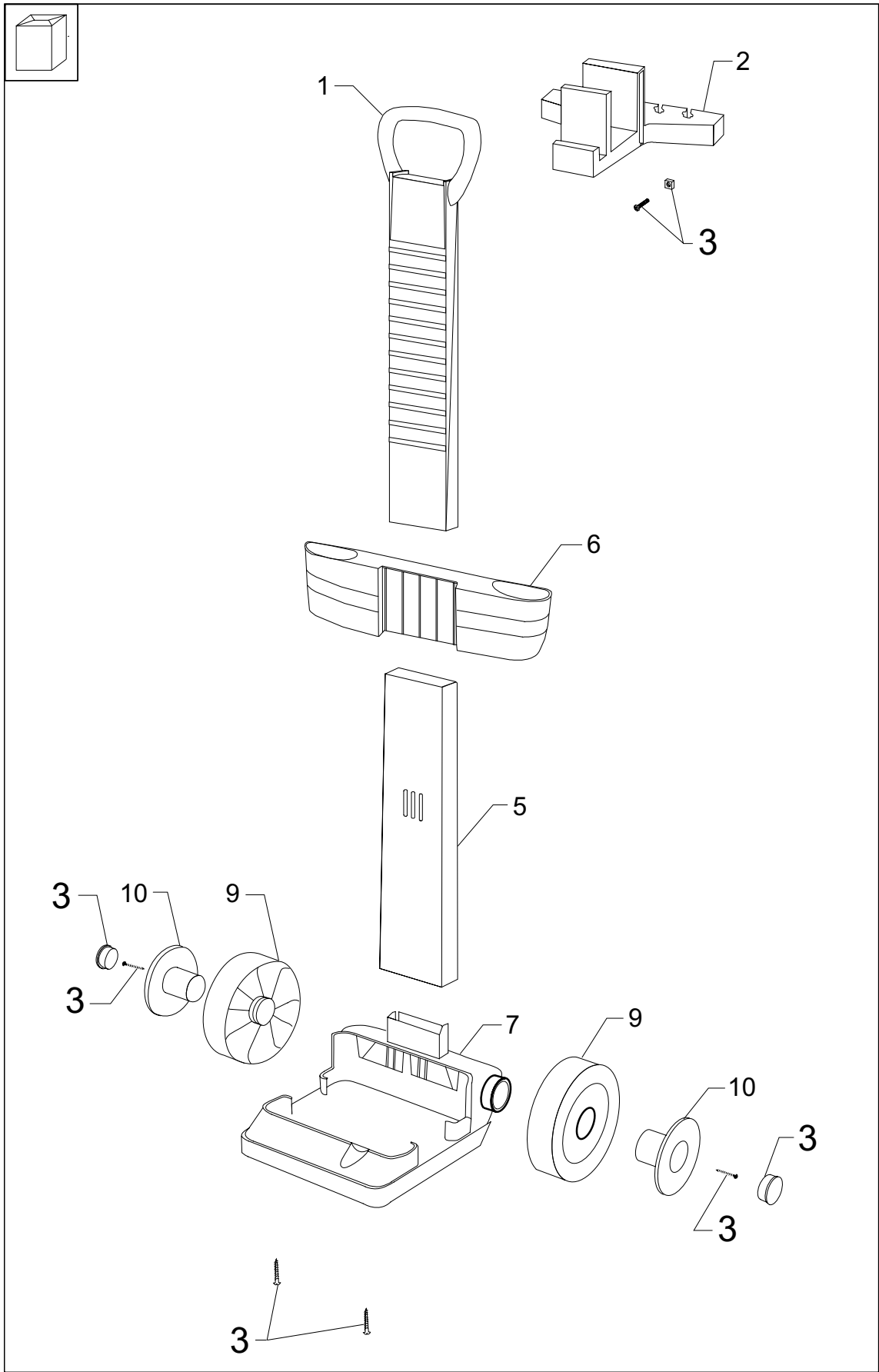

1Tlvog01

