

N/G-6000A/6400A/6600A

Reservedelsliste
Spare parts list
Ersatzteilliste
Liste de pièces détachées

Karosse / Body / Karosserie / Carrosserie	2
Supertrin / Steam block / Dampfstrufe / Etage vapeur	6
Kedel / Boiler / Kessel / Chaudière	8
Svømmer / afkalkning / Float / Decalcification / Swimmer / Entkalknung / Flotteur / Détartrage	11
Oliefyr / Oliburner / Ölbrenner / Brulerur	13
Pumpe / Pump / Pumpe / Pomp	17
Vandtank / Flowstyring / Water tank / Flowstyring / wasserkasten / Stroemungskontrolle / Cuve dea	21
Motor 6000/6400/6600 / Motor 6000/6400/6600 / Motor 6000/6400/6600 / Moteur 6000/6400/6600	25
El-komponenter / Electric components / Elektrische komponente / Composantes électrique	29
Pistol 98 / Pistol 98 / Pistole 98 / Pistolet 98	34
Pistol / Pistol / Pistole / Pistolet	36
Spulerør / Lances / Lanzen / Lance	38

Karosserie / Body / Carrosserie

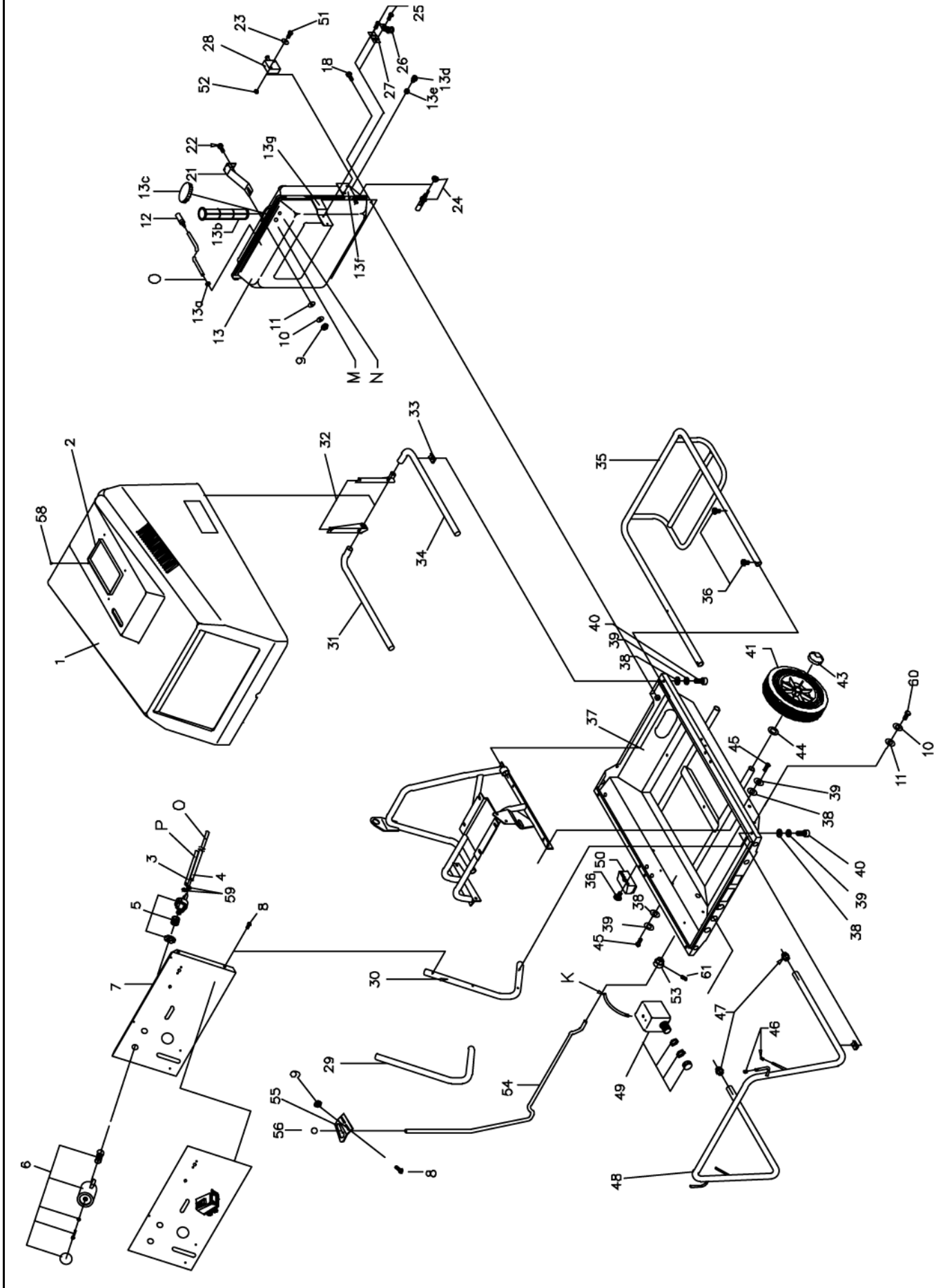

Karosserie / Body / Karosserie / Carrosserie

Pos.	Ref. no.	Betegnelse Description	Bezeichnung Description	6000 A	6400 A	6600 A
0	06301098	TYPESKILT, 100X57 TYPE PLATE, 100X57	TYPESCHILD PLAQUE SIGNALETIQUE	1	1	1
0	06301106	TRANSFER, INSTRUMENTPANEL TRANSFER, INSTRUMENT PANEL	KLEBSTREIFEN F. AMATURENBRETT AUTOCOLLANT TABLEAU DEDE DE CONTROLE	1	1	1
0	06301835	TRANSFER NILFISK 6000 AUT, BLÅ TRANSFER NILFISK 6000 AUT, BLUE	AUTOCOLLANT NILFISK 6000 AUT, BLEU	2		
0	06301862	TRANSFER NILFISK 6400 TRANSFER NILFISK 6400	AUTOCOLLANT NILFISK 6400	2		
0	06301863	TRANSFER NILFISK 6600 TRANSFER NILFISK 6600	AUTOCOLLANT NILFISK 6600			2
0	06301865	TRANSFER GERNI 6000 TRANSFER IGERNI 6000	AUTOCOLLANT GERNI 6000	2		
0	06301912	TRANSFER , 6600A TRANSFERS , 6600A	AUTOCOLLANT , 6600A			2
0	06301923	TRANSFERS GERNI TRANSFERS GERNI	KLEBSTREIFEN GERNI AUTOCOLLANT GERNI	2	2	2
01	06240218	KAROSSE GRÅ, N-6000 BODY GREY, N-6000	KAROSSERIE N-6000 CARROSSERIE N 6000 GRISE	1	1	1
01	06240286	KAROSSE GRØN, G-6000 BODY GREEN, G-6000	CARROSSERIE G 6000 VERTE	1	1	1
02	06060558	DÆKPLADE FOR SKORSTEN , 208X308X1,5 COVER PLATE FOR CHIMNEY, 208X308X1.5	DECKPLATTE FUER SCHORNSTEIN, GALV. PLAQUE COUVERT.P.CHEMINEEMINEE GALV.	1	1	1
03	06261147	KEMISLANGE KPL., 1100 MM DETERGENT HOSE CPL., 1100 MM	REINIGUNGSMITTELSCHLAUCH 1100 MM KPL. TUYAU DE DETERGENT 1100 MM CPL.	1	1	1
04	06261146	KEMISLANGEKIT KPL, 2900 MM G6000 DETERGENT HOSE KIT CPL., 2900 MM G6000	REINIGUNGSMITTELSCHLAUCHKIT 2900 MM KPL. KIT TUYAU DETERGENT 2900 2900 MM CPL.	1	1	1
05	06211201	PLASTVENTIL KOMPLET PLASTIC DETERGENT VALVE CPL.	PLASTIK REINIGUNGSMITTELVENTIL KPL VANNE PLASTIQUE G-2000/60ST. CPL.	1	1	1
06	06260724	PLASTKNAPKIT BUTTON KIT, PLASTIC	KNOPFKIT, PLASTIK KIT BOUCHON PLASTIC (R.06	1	1	1
07	06211137	INSTRUMENTPANEL INSTRUMENT PANEL	INSTRUMENTPANEEL KPL. TABLEAU DE CONTROLE CPL	1	1	1
08	06070393	SKRUE, 6X10 SCREW, 6X10	TAP TITE PIK, GALV. VIS ROBINET P/H GALV.	4	4	4
09	06080058	MØTRIK, M6 NUT, M6	MUTTER, GALV. ECROU	1	1	1
10	06080114	SKIVE, M6 WASHER, M6	STERNSCHEIBE RONDELLE A DENTS	5	5	5
11	06080016	SPÆNDESKIVE, 6 MM TENSION DISC, 6 MM	FEDERSCHEIBE, GALV. RONDELLE DE SERRAGE	5	5	5
12	06100316	FILTER FOR KEMI DETERGENT FILTER	REINIGUNGSMITTELFILTER ASPIRATION DETERGENT	1	1	1
13	06261512	BRÆNDSTOFTANK, KPL. FUEL TANK, CPL.	BRENNSTOFFTANK KPL. RESERVOIR GAS-OIL CPL.CPLCPL. NG-6000	1	1	1

Karosserie / Body / Karosserie / Carrosserie

Pos.	Ref. no.	Betegnelse Description	Bezeichnung Description	6000 A	6400 A	6600 A
13A	06120295	KABELGENNEMFØRING, 10X13X18 CABLE GROMMET, 10X13X18	KABELDURCHFUEHRUNG TRAVERSEE DE CABLE	1	1	1
13B	06100317	BRÆNDSTOFFFILTER FUEL FILTER	BRENNSTOFFFILTER FILTRE CUVE GAS-OILE E	1	1	1
13C	06150093	LAG FOR BRÆNDSTOFFTANK COVER FOR FUEL TANK	DECKEL F. BRENNSTOFFTANK COUVERCLECOMBUSTIB. COMBUSTIB.	1	1	1
13D	06180579	BUNDPROP, Ø24X20 BOTTOM CAP, Ø24X20	BODENPFROPFEN F. OELTANK PRISE SUPERIEURE DE RESERA FUEL	1	1	1
13E	06120232	O-RING, 15X3 O-RING, 15X3	O-RING JOINT	1	1	1
13F	06061066	BESLAG FOR KONTAKT KAROSSE, 102X38X1 GALV. FITTINGS FOR SWITCH - BODY, 102X38X1 GALV.	BESCHLAG F. SCHALTER KAROSSERIE ARMATURE POUR CONTACTEUR CARROSSE	1	1	1
13G	06061017	HOLDER FOR BRÆNDSTOFFFILTER, 50X165X1,5 GAL. HOLDER FOR FUEL FILTER, 50X165X1,5 GAL.	HALTER F. BRENNSTOFFFILTER SUPPORT POUR FILTRE A COMBUSTIBLE	1	1	1
21	06061001	HOLDER FOR OLIETANK, 40X188X2 HOLDER FOR OIL TANK, 40X188X2	HALTER F. OELTANK PATTIE DE LIAISONHUILE HUILE	1	1	1
22	06070742	SKRUE, 6X16 SCREW, 6X16	SCHRAUBE VIS 6X16 GALV.	1	1	1
23	06080046	STJERNESKIVE, M4 TOOTH LOCK WASHER, M4	STERNESCHEIBE, GALV. RONDELLE	2	2	2
24	06170136	NIVEAUFØLER, 2 M CABLE LEVEL CONTROL, 2 M CABLE	NIVEAUWAECHTER JAUGE DE NIVEAU	1	1	1
25	06070392	SKRUE, 5X10 SCREW, 5X10	TAP TITE P/K, GALV. TAP TITE T/L GALV.	2	2	2
26	06080179	RØRHOLDER, 6 MM PIPE HOLDER, 6 MM	ROHRHALTER SUPPORT DE TUYAU	1	1	1
27	06061014	BESLAG, MINI-HOT FITTINGS, MINI-HOT	BESCHLAG F. OELFILTER ARMAT.P.FILTRE HUILE MINIILE	1	1	1
28	06170156	KONTAKT, 16A 250V T85 SWITCH, 16A 250V T85	SCHALTER CONTACTEUR CAPOT 6000	1	1	1
29	06050801	RØR FOR INSTRUMENTPANEL, HØJRE, Ø25X2X631 PIPE FOR INSTRUMENT PANEL, RIGHT, Ø25X2X631	ROHR F. INSTRUMENTPANEEL RECHT TUYAU POUR TABLEAU DE CONTROLE DROITE	1	1	1
30	06050797	RØR FOR INSTRUMENTPANEL, VENSTRE, 25X2X631 PIPE FOR INSTRUMENT PANEL, LEFT, 25X2X631	ROHR F. INSTRUMENTPANEEL LINKS TUYAU POUR TABLEAU DE CONTROLE GAUCHE	1	1	1
31	06050798	RØR FOR HÆNGSEL HØJRE, Ø25X2X580 PIPE FOR HINGE RIGHT, Ø25X2X580	ROHR F. ANGEL RECHT TUYAU POUR CHARNIERE DROITE	1	1	1
32	06261145	HÆNGSELKIT KPL. HINGE KIT CPL.	ANGELKIT KPL. KIT DE CHARNIERE CPL.	1	1	1
33	06200103	AFSTANDSSTYKKE DISTANCE PIECE	ZWISCHENSTUECK ENTRETOISE	1	1	1
34	06050799	RØR FOR HÆNGSEL VENSTRE, Ø25X2X580 PIPE FOR HINGE LEFT, Ø25X2X580	ROHR F. ANGEL LINKS TUYAU POUR CHARNIERE GAUCHE	1	1	1
35	06211136	KEMI BAGAGEBÆRER KPL. DETERGENT CARRIER CPL.	REINIGUNGSMITTELHALTER KPL. DETERGENT PORTE-BAGAGE CPL.	1	1	1

Karosserie / Body / Karosserie / Carrosserie

Pos.	Ref. no.	Betegnelse Description	Bezeichnung Description	6000 A	6400 A	6600 A
36	06070393	SKRUE, 6X10 SCREW, 6X10	TAP TITE P/K, GALV. VIS ROBINET P/H GALV.	6	6	6
37	06211134	BUNDRAMME, KPL, G 6000 BOTTOM FRAME, CPL., G 6000	BODENRAHMEN KPL. CADRE DE FOND	1	1	1
38	06080004	SPÆNDESKIVE, 8,4X17X1,6 TENSION DISC, 8,4X17X1,6	FEDERSKIBE, GALV. RONDELLE	4	4	4
39	06080018	STJERNESKIVE, M8 TOOTH LOCK WASHER, M8	FEDERTELLERSKIBE, GALV. RONDELLE D'ETOILE	9	9	9
40	06070452	UNBRACO SKRUE, M8X20 ALLEN SCREW, M8X20	IMBUSSBOLZEN, GALV. INTRAVIS 8X20 GALV.	4	4	4
41	06130222	HJUL, 25/65-275/70 WHEEL, 25/65-275/70	ROUE PLEINE DURE	4	4	4
43	06280200	LÅSESKIVE, Ø25 LOCK WASHER, Ø25	ENJOLIVEUR ROUE	4	4	4
44	06080075	SPÆNDESKIVE, 45X25,5X1,5 TENSION DISC, 45X25,5X1,5	FEDERSKIBE F. RAD, GALV. RONDELLE DE SERRAGE POUR UUE	4	4	4
45	06070287	SÆTSKRUE, M8X20 SET SCREW, M8X20	VIS D'ARRET, M8X20	5	5	5
46	06200020	DUPSKO, 8 CAP, 8	ZWINGE BOU	4	4	4
47	06200050	RØRSAMLER PIPE JOINT	ROHRSAMMLER COLLECTEUR DE TUYAU	2	2	2
48	06211140	KØREHÅNDTAG OPERATION HANDLE	FAHRHANDGRIFF KPL. BRANCARD	1	1	1
49	06261148	SLAMGLASKIT, 6000 OIL WASTE GLASS KIT, 6000	SCHLAMMGLASKIT KIT VERRE HUILE	1	1	1
50	06060947	SPULERØRSHOLDER LANCE HOLDER	LANZENHALTER SUPPORT DE LANCE	1	1	1
51	06080056	MØTRIK, M4 NUT, M4	MUTTER, GALV. ECROU	2	2	2
52	06070222	SKRUE, 4X20 SCREW, 4X20	SCHRAUBE, Z/K, GALV. VIS A TETE CYL. GALV.	2	2	2
53	06181005	BØSNING, Ø25X22 SLEEVE, Ø25X22	BUCHSE F. BREMSE G-6000 MANCHON POUR FREINS G-6000	2		
55	06061132	LÅSEBESLAG FOR BREMSER, *D LOCK FITTINGS FOR BRAKE, *D	SCHLIESSBESCHLAG F. BREMSE GARNITURE DE SERRURE P. FREINS	1		
56	06200288	KUGLE, M10 Ø32 BALL, M10 Ø32	KUGEL, SCHWARZ BOULETTE(NTE) NTE)	1		
57	06070141	UNBRACO PINOLSKRUE, M6X10 ALLEN POINTED SCREW, M6X10	IMBUSSREITSTOCKSCHRAUBE VIS PIVOT	2		
58	06070873	SKRUE, 4,8X9,5 SCREW, 4,8X9,5	VIS (4,8 X 9,5) DE PLAQUE		4	4
59	06070141	UNBRACO PINOLSKRUE, M6X10 ALLEN POINTED SCREW, M6X10	IMBUSSREITSTOCKSCHRAUBE VIS PIVOT	2	2	2

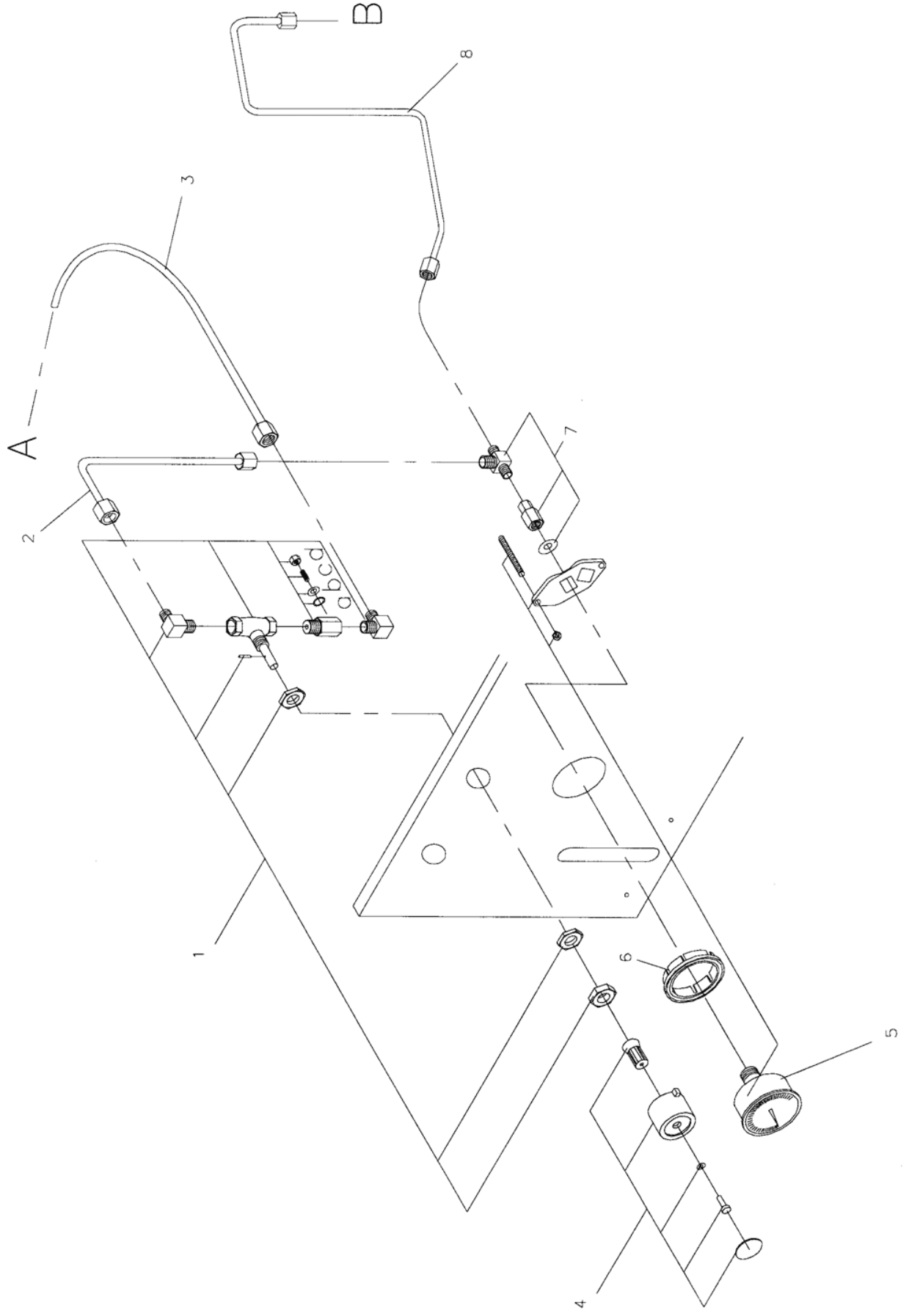

Supertrin / Steam block / Dampfstrufe / Etage vapeur

Pos.	Ref. no.	Betegnelse Description	Bezeichnung Description	6000 A	6400 A	6600 A
01	06262007	DAMPTRINSHANE KIT STEAM DEVICE COCK KIT	KIT DE SUPER-PALIER	1	1	1
01A	06120087	O-RING, 5,28X1,78 O-RING, 5,28X1,78	O-RING JOINT TORIQUE	1	1	1
01B	06080022	SPÆNDESKIVE, M5 TENSION DISC, M5	FEDERSKIBE MESSING RONDELLE DE SERRAGE LAITO	1	1	1
01C	06070138	UNBRACO PINOLSKRUE, M5X16 ALLEN POINTED SCREW, M5X16	IMBUSSREITSTOCKSCHRAUBE, ROSTFREI VIS PIVOTQUE, INOX QUE, INOX	1	1	1
01D	06080057	MØTRIK, M5 NUT, M5	MUTTER MESS ECROU LAITON	1	1	1
02	06261167	RØR FOR SUPERTRIN KPL., TILGANG, 6000 PIPE FOR STEAM BLOCK CPL., INLET, 6000	ROHR F. DAMPFSTUFE KPL. TUYAU POUR ETAGE SUPER CPL.	1	1	1
03	06261169	SERVICEKIT FOR SUPTRINSSLANGE, AFGANG, G6000 SERVICE KIT FOR STEAM BLOCK HOSE, OUTLET, G6000	SERVICEKIT F. DAMPFSTUFESCHLAUCH KIT SERVICE P. TUYAU ETAGE'ETAGE SUPER	1	1	1
04	06260724	PLASTKNAPKIT BUTTON KIT, PLASTIC	KNOPFKIT, PLASTIK KIT BOUCHON PLASTIC (R.06	1	1	1
05	06220042	MANOMETER, 250 BAR PRESSURE GAUGE, 250/3600 BAR/PSI/ETP	TURBO MANOMETER MANOMETRE	1	1	1
05	06220046	TURBO MANOMETER PRESSURE GAUGE W/HOLDER, 250/ 3600 BAR/PSI/ETP	TURBO MANOMETER MANOMETRE	1		
06	06200401	RING FOR MANOMETER RING FOR PRESSURE GAUGE	RING FÜR MANOMETER ANNEAU	1	1	1
07	06261170	SERVICEKIT FOR MANOMETERFORSKRUNING, G-6000 SERVICE KIT FOR PRES. GAUGE SCREW. C, G-6000	SERVICEKIT F. MANOMETERVERSCHRÄUBUNG KIT SERVICE RACCORD DE MA MANOMETRE	1	1	1
08	06261171	RØR FOR MANOMETER KPL. PIPE FOR PRESSURE GAUGE CPL.	ROHR F. MANOMETER KPL. TUYAU POUR MANOMETRE COMP	1	1	1

Kedel / Boiler / Kessel / Chaudière

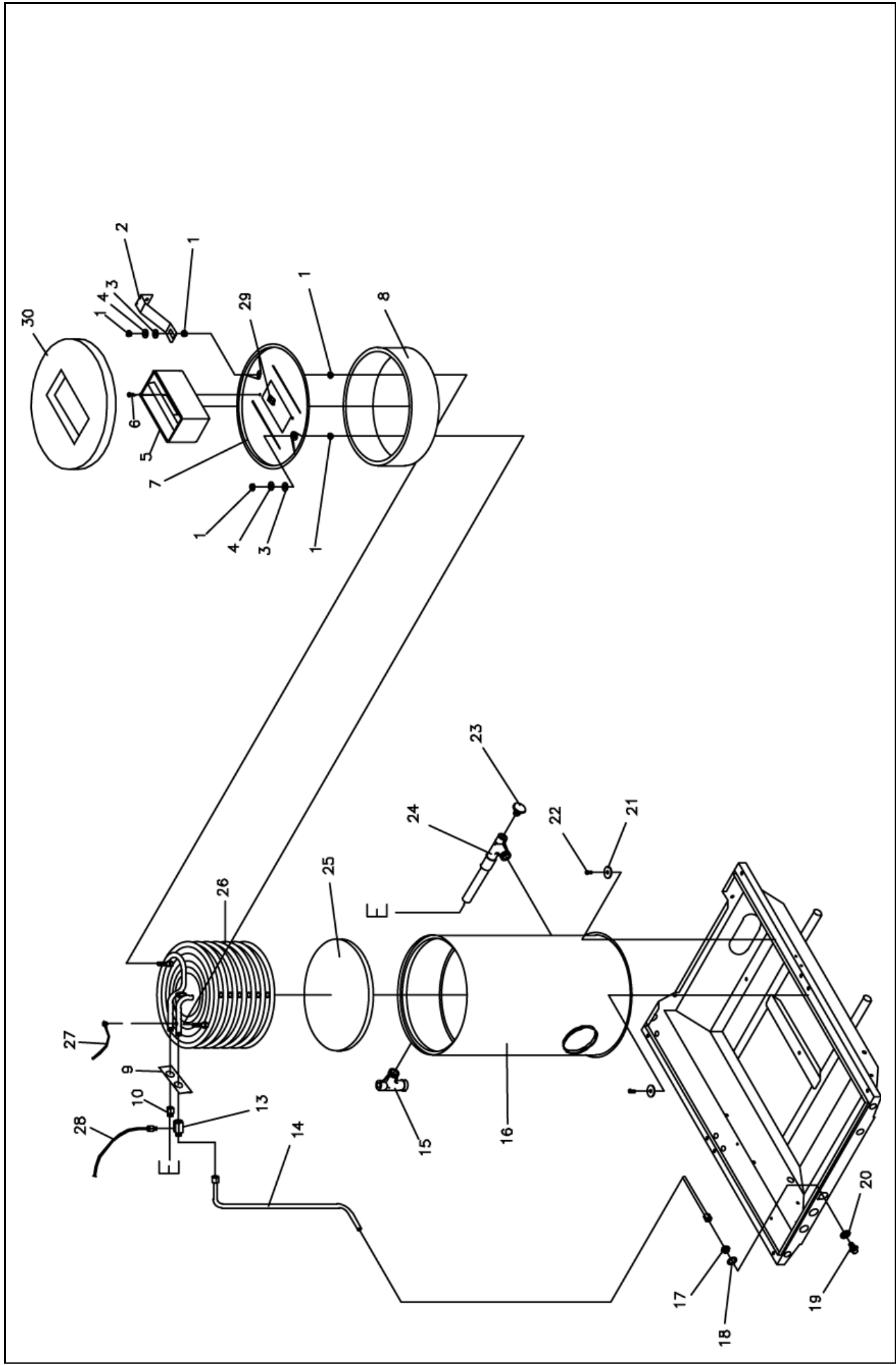

Kedel / Boiler / Kessel / Chaudière

Pos.	Ref. no.	Betegnelse Description	Bezeichnung Description	6000 A	6400 A	6600 A
01	06080007	MØTRIK, M10 NUT, M10	MUTTER, GALV. ECROU	5	5	5
02	06061001	HOLDER FOR OILTANK, 40X188X2 HOLDER FOR OIL TANK, 40X188X2	HALTER F. OILTANK PATTE DE LIAISONHUILE HUILE	1	1	1
03	06080008	SPÆNDESKIVE, 10X19X1,5 TENSION DISC, 10X19X1,5	FEDERSCHEIBE, GALV. RONDELLE DE SERRAGE GALVA	2	2	2
04	06080012	STJERNESKIVE, M10 TOOTH LOCK WASHER, M10	STERNESCHEIBE, GALV. RONDELLE A DENTS	2	2	2
05	06210802	SKORSTEN, KPL. CHIMNEY, CPL.	SCHORNSTEIN KPL. CHEMINEE G-3000	1	1	1
06	06070159	SELVSKÆRENDE SKRUE, 3/4"X14 SELF-TAPPING SCREW, 3/4"X14	SELBSTSCHNEIDENDE SCHRAUBE M.SCHEIB VISE E	2	2	2
07	06060999	TOPPLADE FOR KEDEL, Ø395 TOP PLATE FOR BOILER, Ø395	ZYLINDERPLATTE F. KESSEL ROSTFREI DESSUS CHAUDIERE INOX G 6X	1	1	1
08	06120093	ISOLERING FOR SPIRAL INSULATION FOR COIL, 1050X100X13 MM	KERLANE F. HEIZSCHLANGE HEISSWASSER KERLANE P.SERPENTIN EAU CCHAUDE	1	1	1
09	06060703	DÆKPLADE, 122X55X1 COVER PLATE, 122X55X1	DECKPLATTE F. HEIZSCHLANGEROHR 3000 PLAQUE PASSE FIL TUBESERP SERP G3000	1	1	1
10	06030004	HYDRAULIKFORSKR, 3/8"-10/12 HYDRAULIC SCREWED CONNECTION, 3/8"-10/12	HYDRAULIKVERSCHRÄUBUNG GALVANISIERT RACCORD	1	1	1
10	06030688	HYDRAULIKFORSKRUNING HYDRAULIC SCREWED CONNECTION	HYDRAULIKVERSCHRÄUBUNG JOINT HYDRAULIQUE	1	1	1
13	06180991	FORDELERKLODS, 29X52 DISTRIBUTOR BLOC, 29X52	VERTEILERKLOTZ BLOC DE DISTRIBUTION G-6000	1	1	1
14	06261166	AFGANGSRØR F. SPIRAL OUTLET PIPE FOR COIL	AUSLASSROHR F. SPIRALE KPL. TUYAU DEPART POUR SERPENTIN CPL.	1	1	1
14	06261254	AFGANGSRØR FOR SPIRAL, G-6000 SV OUTLET PIPE FOR COIL, G-6000 SV	AUSLASSROHR F. SPIRALE KPL. TUYAU DE DEPART P. SERPENTIN CPL.	1		
15	06120389	AFGANGSSTUDS, 30 MM OUTLET SOCKET, 30 MM	AUSLASS-STUTZEN ABGEKUEERTZT 30 MM TUBUL. DE DEPART ACCOUR.30CI 30 MM	1	1	1
16	06262297	KEDEL, G6000 BOILER, G6000	CHAUDIÈRE 6000-6400-6600	1	1	1
17	06190062	MØTRIK, 27X10 NUT, 27X10	GEGENMUTTER CONTRE-ECROU LAITON M22 X	1	1	1
18	06120184	PAKNING GASKET	DICHTUNG JOINT DIAM 28,5 X 22 X 2,	1	1	1
19	06180488	AFGANGSSTUDS, 24X52 OUTLET SOCKET, 24X52	AUSLASSSTUTZEN RACCORD DE SORTIE NV 27 X	1	1	1
20	06120183	PAKNING GASKET	DICHTUNG JOINT DIAM 38,5 X 27 X 2,	1	1	1
21	06080201	SPÆNDESKIVE, M8 TENSION DISC, M8	FEDERSCHEIBE, GALV. DISQUE	4	4	4
22	06070726	SKRUE, 6X10 SCREW, 6X10	SCHRAUBE, P/K VIS P/H , INOX	4	4	4

Kedel / Boiler / Kessel / Chaudière

Pos.	Ref. no.	Betegnelse Description	Bezeichnung Description	6000 A	6400 A	6600 A
23	06200134	AFTAPNINGSPROP, RØD, Ø38X27 OIL PLUG, RED, Ø38X27	ABZAPFSTOPFEN BOUCHON PLASTIQUEROUGE ROUGE	1	1	1
24	06110495	TILGANGSSLANGE, 3/4"X900 INLET HOSE, 3/4"X900	EINLASS-SCHLAUCH F. KESSEL KPL. TUYAU D'ENT.P.CHAUDIERE CRE CPL.	1	1	1
25	06120108	FIBERRONDEL, Ø335X16 INSULATION, Ø335X16	KERLANE 45 ISOLIERUNG KERLANE 45	1	1	1
26	06211158	SPIRAL, 7-L 6000 HEATING COIL, 7-L 6000	SERPENTIN G 6000	1	1	1
27	06211277	OVERKOGS-TERMOSTAT KPL., G2000/6000 PRIMING THERMOSTAT, CPL., G2000/6000	SCHALTER KPL. SONDE DE SURCHAUFFE	1	1	1
28	06211276	TEMPERATURFØLER KPL., G6000 THERMAL PROTECTOR CPL., G6000	TEMPERATURWAECHTER KPL. DETECTEUR INTERNE DE TEMPERATURE CPL.	1	1	1
29	06080106	SNU-SPEED MØTRIK, 14 SNU-SPEED NUT, 14	SNU-SPEED MUTTER ECROU CHEMINEE SERIE 6000 950	1	1	1
30	06120550	ISOLERING, Ø375X30 INSULATE, Ø375X30	ISOLATION	1	1	1

Svømmer / afkalkning / Float / Decalcification / Swimmer / Entkalkning / Flotteur / Détartrage

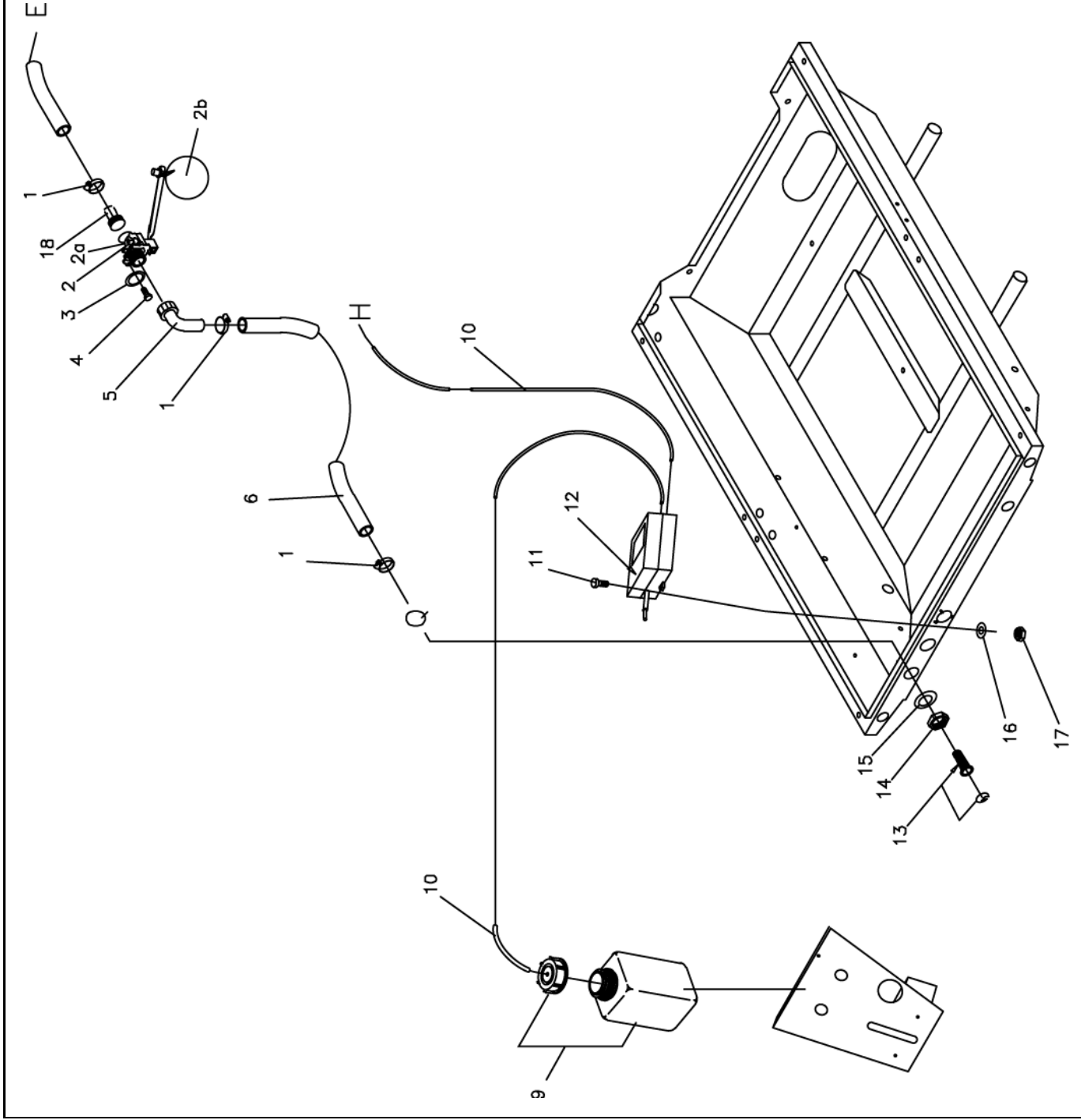

Svømmer / afkalkning / Float / Decalcification / Swimmer / Entkalkning / Flotteur / Détartrage

Pos.	Ref. no.	Betegnelse Description	Bezeichnung Description	6000 A	6400 A	6600 A
02	06100253	SVØMMERVENTIL FLOAT VALVE	SCHWIMMERTVENTIL KOMPL. VANNE FLOTTEUR	1	1	1
02A	06100312	MEMBRAN MEMBRANE	MEMBRAN F. SCHWIMMERTVENTIL MEMBRANE POS. 15F VANNE A FLOTTEUR	1	1	1
02B	06100410	KUGLE BALL	BILLE	1	1	1
03	06080014	SPÆNDESKIVE, M4 TENSION DISC, M4	FEDERSKEIBE, GALV. RONDELLE DE SERRAGE	2	2	2
04	06070481	SKRUE, 6 MM SCREW, 6 MM	BLINDNIETE STAHL RIVET TUBULAIRE D'ACIER	2	2	2
05	06030681	VINKELSTUDS, 3/4" ANGLE SOCKET, 3/4"	WINKELSTUTZEN PLASTIK RACCORD EQUERRE PLASTIQUE	1	1	1
06	06110459	ARMERET PLASTSLANGE, 700 MM ARMOURED PLASTIC HOSE, 700 MM	ARMERTER PLASTIKSCHLAUCH SCHWARZ TUYAU EN PLASTIQUE ARME NNOIR	1	1	1
09	06150099	FLASKE M. LAG BOTTLE W. COVER	KAUTEK FLASCHE M/DECKEL BOCAL P/SYSTEME ANTI CALC	1	1	1
10	06110354	PLASTSLANGE, Ø3X900 PLASTIC HOSE, Ø3X900	PLASTIKSCHLAUCH F. ENTKALKUNG BRIDE EN PLASTIQUE	2	2	2
11	06070220	SKRUE, 4X10 SCREW, 4X10	SCHRAUBE Z/K GALV. VIS T/C GALV.	1	1	1
12	06170131	DOSERINGSPUMPE, 24V/50 HZ DOSING PUMP, 24V/50 HZ	DOSIERPUMPE F. ENTKALKUNGSANLAGE POMPE DOSAGE ANTI TARTRE	1	1	1
13	06260825	VANDFILTERKIT, G-100 WATER FILTER KIT, G-100	WASSERFILTERKIT FILTRE EAU G 100	1	1	1
14	06180384	KONTRAMØTRIK, 3/4" COUNTER NUT, 3/4"	GEGENMUTTER CONTRE ECROU NV 32 X 8	1	1	1
15	06120183	PAKNING GASKET	DICHTUNG JOINT DIAM 38.5 X 27 X 2.	1	1	1
16	06080046	STJERNESKIVE, M4 TOOTH LOCK WASHER, M4	STERNSKEIBE, GALV. RONDELLE	1	1	1
17	06080056	MØTRIK, M4 NUT, M4	MUTTER, GALV. ECROU	1	1	1
18	06030140	VANDSLANGEFORSKRNING, F/VANDTILGANG, 3/4" X WATER HOSE COUPLING, FOR WATER CON., 3/4" X 3/4"	WASSERSCHLAUCHVERSCHRABUNG JOINT DE TUYAU D'EAU 3/4X"	1	1	1

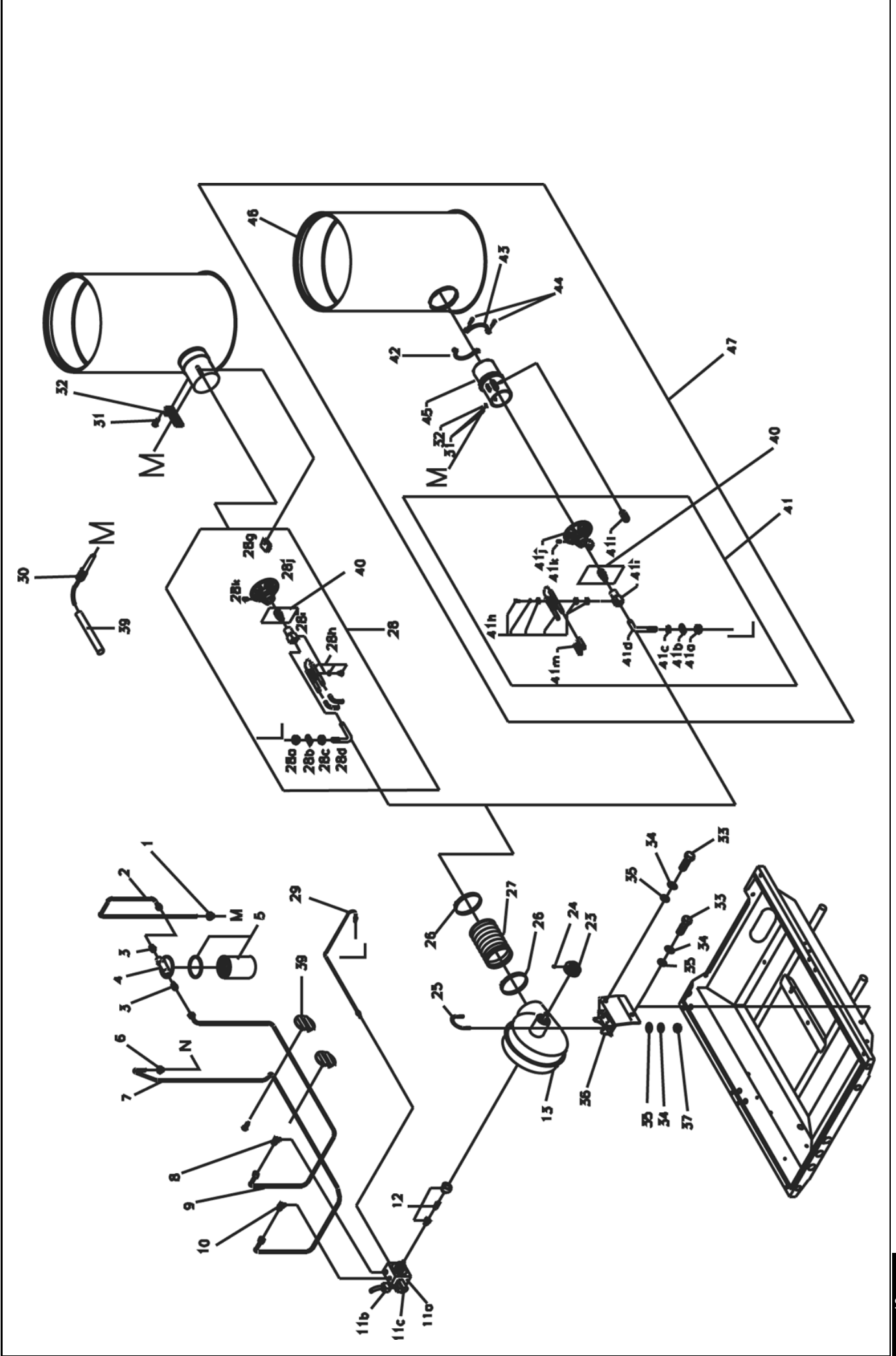

Oliefyr / Oilburner / Ölbrenner / Brulerur

Pos.	Ref. no.	Betegnelse Description	Bezeichnung Description	6000 A	6400 A	6600 A
01	06120106	PAKDASE, C 7-10 STUFFING BOX, C 7-10	STOPFBUCHSE PRESSE-ETOUPE	1	1	1
02	06261163	TILGANGSRØR FOR OLIEFILTER KPL. INLET PIPE FOR OIL FILTER CPL.	EINLASSROHR F. OELFILTER KPL. TUYAU D'ENTREE P. FILTREA HUILE CPL.	1	1	1
03	06030527	BRYSTNIPPEL, 8X1/4" BREAST NIPPLE, 8X1/4"	GEWINDESTUECK RACCORD	2	2	2
04	06230260	FLANGE FOR BRÆNDSTOFFILTER FLANGE FOR FUEL FILTER	FLANSCH F. OELFILTER BRIDE P. FILTRE A HUILE	1	1	1
05	06230263	FILTERPATRON FILTER COLLET	FILTERFUTTER KIT CARTOUCHE	1	1	1
06	06120111	PAKDASE, C 5-7 STUFFING BOX, C 5-7	STOPFBUCHSE PRESSE-ETOUPE CAOUTCHOUC	1	1	1
07	06261161	AFGANGSRØR FOR OLIEPUMPE KPL. OUTLET PIPE FOR OIL PUMP CPL.	AUSLASSROHR F. OELPUMPE KPL. TUYAU DE DEP.P.POMPE HUILE D"HUILE CPL.	1	1	1
08	06030584	VINKELNIPPEL, 8X1/4" ANGLE NIPPLE, 8X1/4"	WINKELNIPPEL RACCORD	1	1	1
09	06261160	TILGANGSRØR FOR OLIEPUMPE KPL. INLET PIPE FOR OIL PUMP CPL.	EINLASSROHR F. OELPUMPE KPL. TUYAU D'ENTREE POUR POMPE D"HUILE CPL.	1	1	1
10	06030503	VINKELNIPPEL, 6X1/4" ANGLE NIPPLE, 6X1/4"	WINKELNIPPEL RACCORD COUDE	1	1	1
11	06261040	BRÆNDSTOFFUMPE KPL., 24 V FUEL PUMP CPL., 24 V	SERVICEKIT F. OELPUMPE KIT DE SERVICE POMPE HUIL D'HUILE	1	1	1
11A	06230303	OLIEPUMPE 24V 50/60HZ FUEL PUMP WITH COIL, 24V 50/60HZ	OELPUMPE POMPE HUILE G-5000	1	1	1
11B	06160771	LEDNING FOR BRÆNDSTOFFUMPE CABLE FOR FUEL PUMP	KABEL F. OELPUMPE CABLE ELECTROVANNE	1	1	1
11C	06230306	SPOLE F. MAGNETVENTIL 24V COIL FOR MAGNET VALVE, 24V	SPULE F. OELPUMPE BOBINE P.POMPE D'HUILE G-	1	1	1
12	06260861	KIT F. KOBLING OLIEPUMPE FUEL PUMP COUPLING KIT	OELPUMPE KUPPLUNGSKIT KIT ACCOUPLEMENT POMPE GAPLEMENT	1	1	1
13	06230301	BLÆSERHUS M. AKSEL, KPL. BLOWER HOUSING W. AXLE, CPL.	GEBLÆSEGEHÆUSE M. WELLE KPL. CORPS SOUFFLANT G-6000E CE CPL.	1	1	1
23	06130189	KILEREMSKIVE	KEILRIEMENSCHIBE POULIE COUR.ARB.R.POMPEEZOZOIDALE	1	1	1
24	06070047	UNBRACO PINOLSKRUE, M6X6 ALLEN POINTED SCREW, M6X6	IMBUSSREITSTOCKSCHRAUBE VISQUE QUE	2	2	2
25	06040151	BØJLE FOR BLÆSERHUS, Ø8X190 CLAMP FOR IMPELLER HOUSING, Ø8X190	BUEGEL F.GEBLÆSEGEHÆUSE BRIDEFFLEUR	1	1	1
26	06110162	SPÆNDEBAND, Ø10X170 RETAINING RING, Ø10X170	SCHLAUCHSCHELLE FRETTE	2	2	2
27	06110468	SUPERFLEX FOR OLIEFYR SUPER TUBING FOR OIL BURNER, Ø102X200	SUPERFLEX F. OELBRENNER SOUFFLET	1	1	1
28	06261164	BRÆNDERINDSATS KPL. UDEN DYSE BURNER INSERT CPL. WITHOUT NOZZLE	BRENNEREINSATZ KPL. INTERIEUR DE BRULEUR CPL.	1	1	1

Oliefyr / Ölbrüner / Ölbrüner / Brülerur

Pos.	Ref. no.	Betegnelſe Description	Bezeichnung Description	6000 A	6400 A	6600 A
28A	06230216	FINGERMØTRIK FOR DYSERØR, Ø22X10 NUT FOR PIPE FOR NOZZLE, Ø22X10	MUTTER F. DUESENROHR ECROUUR	1	1	1
28B	06230215	DÆKPLADE FOR OILIERØR, 30X20X1,5 COVER PLATE FOR OIL PIPE; 30X20X1,5	DECKPLATTE F. OELROHR PLAQUE DE COUVERTURE P. TUYAU D'HUILE	1	1	1
28C	06080008	SPÆNDESKIVE, 10X19X1,5 TENSION DISC, 10X19X1,5	FEDERSCHEIBE, GALV. RONDELLE DE SERRAGE GALVA	1	1	1
28D	06050431	DYSERØR FOR OLIEFYR, Ø10X3,5X153 NOZZLE PIPE FOR OIL BURNER; Ø10X3,5X153	DUESENROHR F. OELBRENNER G-3000/6000 TUYAU DE GICLEUR P. BRULEUR G-3000/6000	1	1	1
28G	06230158	MANCHET FOR TÆNDKABEL CUP FOR IGNITION CABLE	MANSCHE F. ZUENDKABEL COUPELLE P. CABLE ALLUMAGEAGE	1	1	1
28H	06261085	KIT FOR ELEKTRODE ELECTRODE KIT	KIT F. ELEKTRODE G-1500/G-2000 KIT ELECTRODE G 1500-2000000/60	1	1	1
28I	06180368	DYSEHOLDER, 19X34 NOZZLE HOLDER, 19X34	DUESENVERSCHRAUBUNG F. OELBRENNER JOINT NV 19 X34LEUR LEUR	1	1	1
28J	06230228	BLANDESKIVE MIXING DISC	STAUSCHEIBE DISQUE DE DIFFUSION	1	1	1
28K	06070368	SKRUE, M4X8 SCREW, M4X8	IMBUSS Z/K, ROSTFREI VIS PIVOT 4 X8 T/C INOX. T/C INOX.	1	1	1
29	06261162	TRYKRØR FRA OLIEPUMPE KPL., G6000 PRESSURE PIPE OIL PUMP CPL., G6000	DRUCKROHR F. OELPUMPE KPL. TUYAU PRESSION POMPEE D'HE D'HUILE CPL.	1	1	1
30	06230328	FOTOCELLE PHOTOCELL	PHOTOZELLE CELLULE PHOTOELECTRIQUE G	1	1	1
31	06070024	SELVSKÆRENDE SKRUE, 1/2"X8 SELF-TAPPING SCREW, 1/2"X8	SELBSTSCHNEIDENDE SCHRAUBE VIS TARAUDEUSE GALVA	2	2	2
32	06230329	FLANGE FOR FOTOCELLE FLANGE FOR PHOTOCELL	FLANSCH F. PHOTOZELLE BRIDE P.CELL.PHOTOELECT.GCTRIQUE	1	1	1
33	06070003	SÆTSKRUE, M8X20 SET SCREW, M8X20	SETZSCHRAUBE, GALV VIS D'ARRET, GALVANISEE	2	2	2
34	06080018	STJERNESKIVE, M8 TOOTH LOCK WASHER, M8	FEDERTELLERSCHEIBE, GALV. RONDELLE D'ETOILE	3	3	3
35	06080004	SPÆNDESKIVE, 8,4X17X1,6 TENSION DISC, 8,4X17X1,6	FEDERSCHEIBE, GALV. RONDELLE	3	3	3
36	06211139	KONSOL FOR BLÆSERHUS BRACKET FOR BLOWER HOUSING	WAND F. GEBLÆSEGEHÆUSE KPL. CONSOLE POUR CORPS SOUFFLANT CPL.	1	1	1
37	06080002	MØTRIK, M8 NUT, M8	MUTTER, GALV. ECROU	1	1	1
39	06160854	GLASFLEX, 350 MM GLASS TUBING, 350 MM	GLAS-FLEX ABGEKUEZT G-6000 VERRE	1		
40	06230293	OLIEDYSE 2,50 GALL OIL NOZZLE; 2,50 GALL 80GR-H	OELDUESE 2,50 GALL. 80H 8,0 KG GICLEUR FUEL 2,5 80pON ON		1	
40	06230313	OLIEDYSE 2,00 GALL OIL NOZZLE; 2,00 GALL 6,3 KG 80GR-H	OELDUESE GICLEUR GAS-OIL 2.00 G-50LLONS	1		1
41	06262296	BRÆNDER KPL G6000 BURNER INSERT CPL. WITHOUT NOZZLE, G6000	INTERIEUR DE BRULEUR CPL. S/GICL., G6000	1	1	1

Oliefyr / Oilburner / Ölbrenner / Brulerur

Pos.	Ref. no.	Betegnelse Description	Bezeichnung Description	6000 A	6400 A	6600 A
41A	06230216	FINGERMØTRIK FOR DYSERØR, Ø22X10 NUT FOR PIPE FOR NOZZLE, Ø22X10	MUTTER F. DUESENROHR ECROUUR	1	1	1
41B	06230215	DÆKPLADE FOR OLIERØR, 30X20X1,5 COVER PLATE FOR OIL PIPE, 30X20X1,5	DECKPLATTE F. OELROHR PLAQUE DE COUVERTURE P. TUYAU D'HUILE	1	1	1
41C	06080008	SPÆNDESKIVE, 10X19X1,5 TENSION DISC, 10X19X1,5	FEDERSKEIBE, GALV. RONDELLE DE SERRAGE GALVA	1	1	1
41D	06051043	DYSERØR FOR OLIEFYR, Ø10X4,5X103 NOZZLE PIPE FOR OIL BURNER, Ø10X4,5X103	TUYAU DE GICLEUR POUR BRULEUR, □10X4,5X103	1	1	1
41H	06261085	KIT FOR ELEKTRODE ELECTRODE KIT	KIT F. ELEKTRODE G-1500/G-2000 KIT ELECTRODE G 1500-2000000/60	1	1	1
41I	06180924	DYSEHOLDER, 20X20X44 NOZZLE HOLDER, 20X20X44	DUESENHALTER SUPPORT DE GICLEUR	1	1	1
41J	06230331	BLANDESKIVE MIXING DISC	LUFTMISCHSCHEIBE DISQUE D'EMULSION G-3000/	1	1	1
41K	06070368	SKRUE, M4X8 SCREW, M4X8	IMBUSS Z/K, ROSTFREI VIS PIVOT 4 X 8 T/C INOX T/C INOX	1	1	1
42	06110512	SPÆNDEBESLAG, Ø110 FITTINGS, Ø110	BESCHLAG CERCLE D'ASSEMBLÉUR DR	1	1	1
43	06110520	SPÆNDEBESLAG, Ø110 FITTINGS, Ø110	BESCHLAG CERCLE D'ASSEMBLÉUR GA	1	1	1
44	06070800	UNBRACO SKRUE, M6X30 ALLEN SCREW, M6X30	IMBUSS 8,8 GALV VIS CULASSE POUR G-880	1	1	1
45	06230375	BRÆNDERRØR, G6000 BURNER PIPE, G6000	TUYAU COMBUSTIBLE, G6000	1	1	1
46	06262297	KEDEL, G6000 BOILER, G6000	CHAUDIERE 6000-6400-6600	1	1	1
47	06211251	KEDEL KOMPLET+BRÆNDERØR KEDEL, CPL. - INCL BURNER, EXCL. NOZZLE, G6000	KESSEL G-6000 CHAUDIERE G 6000	1	1	1

Pumpe / Pump / Pumpe / Pomp

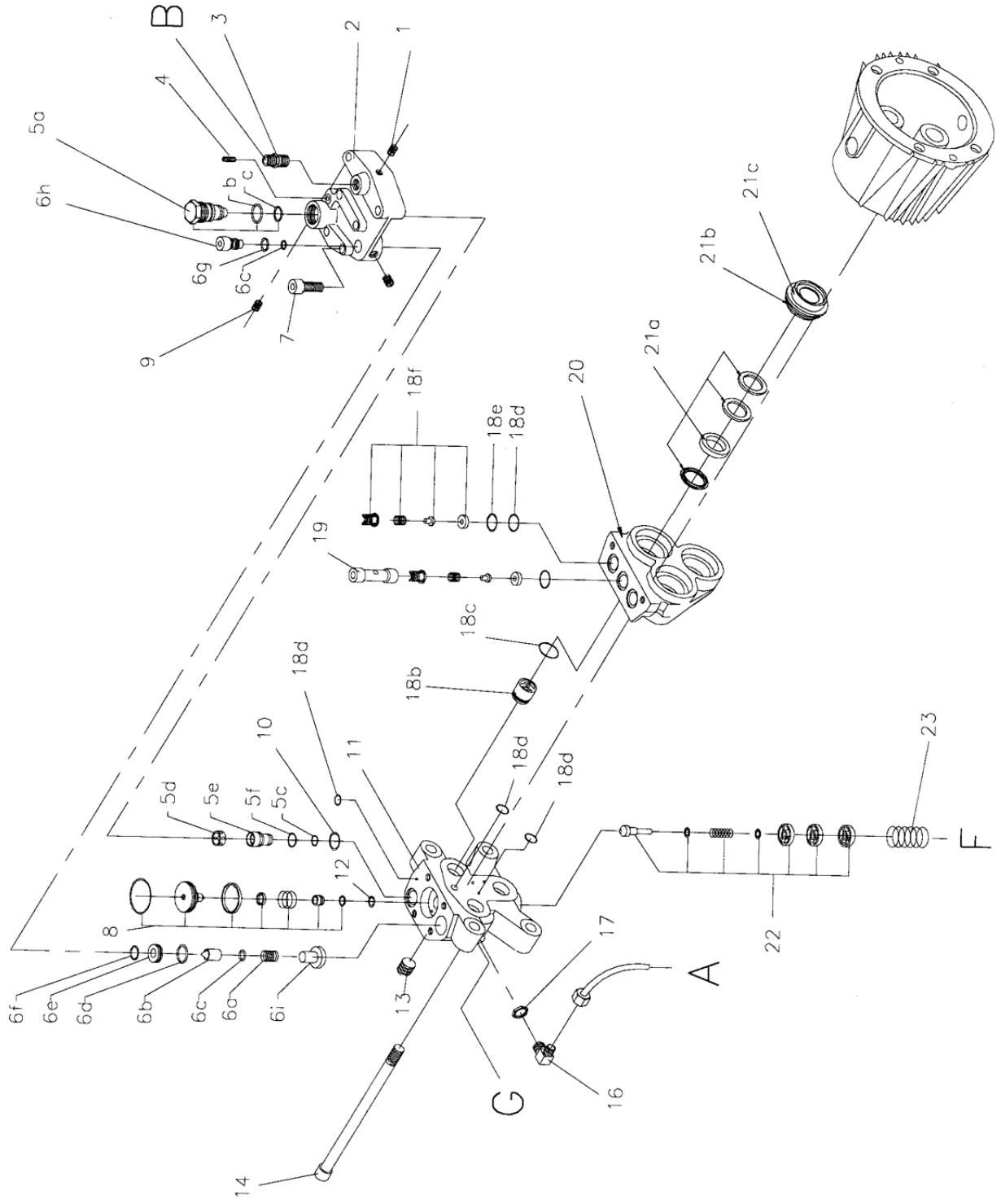

Pumpe / Pump / Pumpe / Pomp

Pos.	Ref. no.	Betegnelse Description	Bezeichnung Description	6000 A	6400 A	6600 A
0	06120024	O-RING, 9,25X1,78 O-RING, 9,25X1,78	O-RING JOINT TORIQUE MAT 4470	1	1	1
0	06120042	O-RING, 9,1X1,6 O-RING, 9,1X1,6	O-RING JOINT TORIQUE	1	1	1
0	06120047	O-RING, 28,3X1,78 O-RING, 28,3X1,78	O-RING JOINT TORIQUE 28,3 X 1,78	1	1	1
0	06120087	O-RING, 5,28X1,78 O-RING, 5,28X1,78	O-RING JOINT TORIQUE	1	1	1
0	06120271	O-RING, 37,82X1,78 O-RING, 37,82X1,78	O-RING JOINT	1	1	1
0	06261445	O-RINGSKIT FOR PUMPE, 600/660/5/6000 O-RING KIT FOR PUMP, 600/660/5/6000	KIT O-RINGE F. PUMPE KIT JOINT TORIQUE P.POMPEPOMPE	1	1	1
0	06262259	TOPSTYKKE, KPL., G6400 CYLINDER HEAD, CPL., G6400	CULASSE DE CYLINDRE, CPL., G6400	1		
0	06262260	TOPSTYKKE, KPL., 6600 CYLINDER HEAD, CPL., 6600	CULASSE DE CYLINDRE, CPL., 6600	1		1
01	06030554	RØRPROP, 1/8" PLUG FOR PIPE, 1/8"	ROHRSTOPFEN RACCORD	4	4	4
02	06180755	TRYKMANIFOLD, 600 PRESSURE MANIFOLD , 600	DRUCKMANIFOLD COLLECTEUR PRESSION G 600	1	1	1
03	06030468	HYDRAULIKFORSKRUNING, 1/4" HYDRAULIC SCREWED CONNECTION, 1/4"	HYDRAULIKVERSCHRAUBUNG GALV. JOINT TUYAU + RACCORD 1/4.	1	1	1
04	06070755	UNBRACO PINOLSKRUE, M5X16 ALLEN POINTED SCREW, M5X16	REITSTOCKSCHRAUBE INWENDIG 6 KT VIS PIVOT INTERIEURE 6KTDDIN915	1	1	1
05	06261154	SERVICEKIT INJECTORDYSE, G6000 SERVICE KIT INJECTOR NOZZLE, G6000	SERVICEKIT INJEKTORUESE KIT INJECTEUR DETERGENT D "INJECTEUR	1		1
05	06261431	SERVICEKIT INJECTORDYSE, G640 SERVICE KIT INJECTOR NOZZLE, G640	KIT F. INJEKTORUESE KIT POUR GICLEURR G-640 R G-640	1		
05B	06120270	O-RING, 15,6X1,78 O-RING, 15,6X1,78	O-RING JOINT TORIQUE	1	1	1
05C	06120182	O-RING, 16X2 O-RING, 16X2	O-RING JOINT TORIQUE	2	2	2
05F	06120042	O-RING, 9,1X1,6 O-RING, 9,1X1,6	O-RING JOINT TORIQUE	1	1	1
06	06260899	SIKKERHEDSVENTILKIT SAFETY VALVE KIT, G 600	SICHERHEITSVENTILKIT KIT VANNE BY PASS G-600-6-600	1	1	1
06C	06120182	O-RING, 16X2 O-RING, 16X2	O-RING JOINT TORIQUE	2	2	2
06D	06120308	O-RING, 17,17X1,78 O-RING, 17,17X1,78	O-RING JOINT TORIQUE G 600	1	1	1
06F	06120267	O-RING, Ø10,82X1,78 O-RING, Ø10,82X1,78	O-RING JOINT	1	1	1
06G	06120337	O-RING, 6,07X1,78 O-RING, 6,07X1,78	O-RING JOINT TORIQUE	1	1	1

Pumpe / Pump / Pumpe / Pomp

Pos.	Ref. no.	Betegnelse Description	Bezeichnung Description	6000 A	6400 A	6600 A
07	06070510	UNBRACO SKRUE, M10X40 ALLEN SCREW, M10X40	IMBUSSBOLZEN, GALV. BOULON G 600	6	6	6
08	06260900	OMLØBSVENTILKIT BY-PASS VALVE KIT	UMLAUFVENTILKIT KIT VANNE BY-PASS G600	1		1
08	06261901	OMLØBSVENTILKIT BY-PASS VALVE KIT	UMLAUFVENTILKIT KIT VANNE BY PASS		1	
09	06070456	UNBRACO PINOLSKRUE, M6X6 ALLEN POINTED SCREW, M6X6	IMBUSS-REITSTOCKSCHRAUBE ROSTFREI VIS INOX INOX	1	1	1
10	06120415	O-RING, 17.17X1,78 O-RING, 17.17X1,78	O-RING JOINT TORIQUE 17,17X1,78	1	1	1
11	06180749	PUMPEHOVED, G600 PUMP HEAD, G600	PUMPENKOPF CULASSE G 600	1	1	1
12	06080188	FORMINDSKERSKIVE, 12X5X0,5 REDUCER DISC, 12X5X0,5	REDUZIERSCHEIBE, ROSTFREI RONDELLE		1	
12	06080204	FORMINDSKERSKIVE, Ø12XØ3,0X0,5 REDUCER DISC, Ø12XØ3,0X0,5	REDUZIERSCHEIBE F. STROEMUNGSKONTROLLE RONDELLEITE DE FLOW ITE DE FLOW	1		1
13	06030642	RØRPROP, 3/8" PLUG FOR PIPE, 3/8"	ROHRPFROPFEN BOUCHON DE TUBE	1	1	1
14	06070492	UNBRACO SKRUE, M12X200 ALLEN SCREW, M12X200	IMBUSSBOLZEN BOULON 12X200 G 600	4	4	4
16	06030503	VINKELNIPPEL, 6X1/4" ANGLE NIPPLE, 6X1/4"	WINKELNIPPEL RACCORD COUDE	1	1	1
17	06180515	MØTRIK, 17X2,5 NUT, 17X2,5	MUTTER ECROU BRONZE	1	1	1
18	06260894	VENTILKIT VALVE KIT	VENTILKIT KIT POMPE A EAU CLAPET G-WER	1	1	1
18+21	06261284	KIT FOR PUMPE, 617/6000 KIT FOR PUMP, 617/6000	KIT F. PUMPE G-617+P+ST/G-6000 KIT POMPE A EAU G600/6000T G-6000		1	
18+21	06261446	KIT FOR PUMPE, 660/5000 KIT FOR PUMP, 660/5000	KIT F. PUMPE G-660/5000 KIT POMPE A EAU (NOUVEAU)	1		1
18A	06120175	O-RING, 16X2 O-RING, 16X2	O-RING, 90 SHORE JOINT	3	3	3
18C	06120323	O-RING, 21.95X1,78 O-RING, 21.95X1,78	O-RING JOINT TORIQUE G 600	3	3	3
18D	06120308	O-RING, 17.17X1,78 O-RING, 17.17X1,78	O-RING JOINT TORIQUE G 600	1	1	1
18E	06120267	O-RING, Ø10,82X1,78 O-RING, Ø10,82X1,78	O-RING JOINT	1	1	1
19	06180753	AFSTANDSSTYKKE, Ø16X55 DISTANCE PIECE, Ø16X55	ZWISCHENSTUECK ENTRETOISE G 600	1	1	1
20	06180750	ZYLINDERSTYKKE CYLINDER PIECE	ZYLINDERSTUECK CULASSE G 600	1	1	1
21	06260895	MANCHETKIT CUP KIT FOR STEEL PISTON, G617/620/640	MANSCHEITENKIT F. G-617/620/640 KIT COUPELLES G 6000/640 0/640		1	

Pumpe / Pump / Pumpe / Pomp

Pos.	Ref. no.	Betegnelse Description	Bezeichnung Description	6000 A	6400 A	6600 A
21	06261444	MANCHET KIT FOR KERAMIKSTEMPEL CUP KIT FOR CERAMIC PISTON	KIT F. MANSCHETTE G-660/5000 KIT POMPE A EAU COUPELLES000	1	1	1
21B	06120070	O-RING, 40X2 O-RING, 40X2	O-RING JOINT TORIQUE	3	3	3
22	06261005	KONTRAVENTILKIT, G-600 NON-RETURN VALVE KIT, G-600	RUECKSCHLAGVENTILKIT KIT VANNE ANTI RETOURG-60G-600	1	1	1
23	06280115	FJEDER, 2X23.75X40X4 SPRING, 2X23.75X40X4	FEDER RESSORT	1	1	1

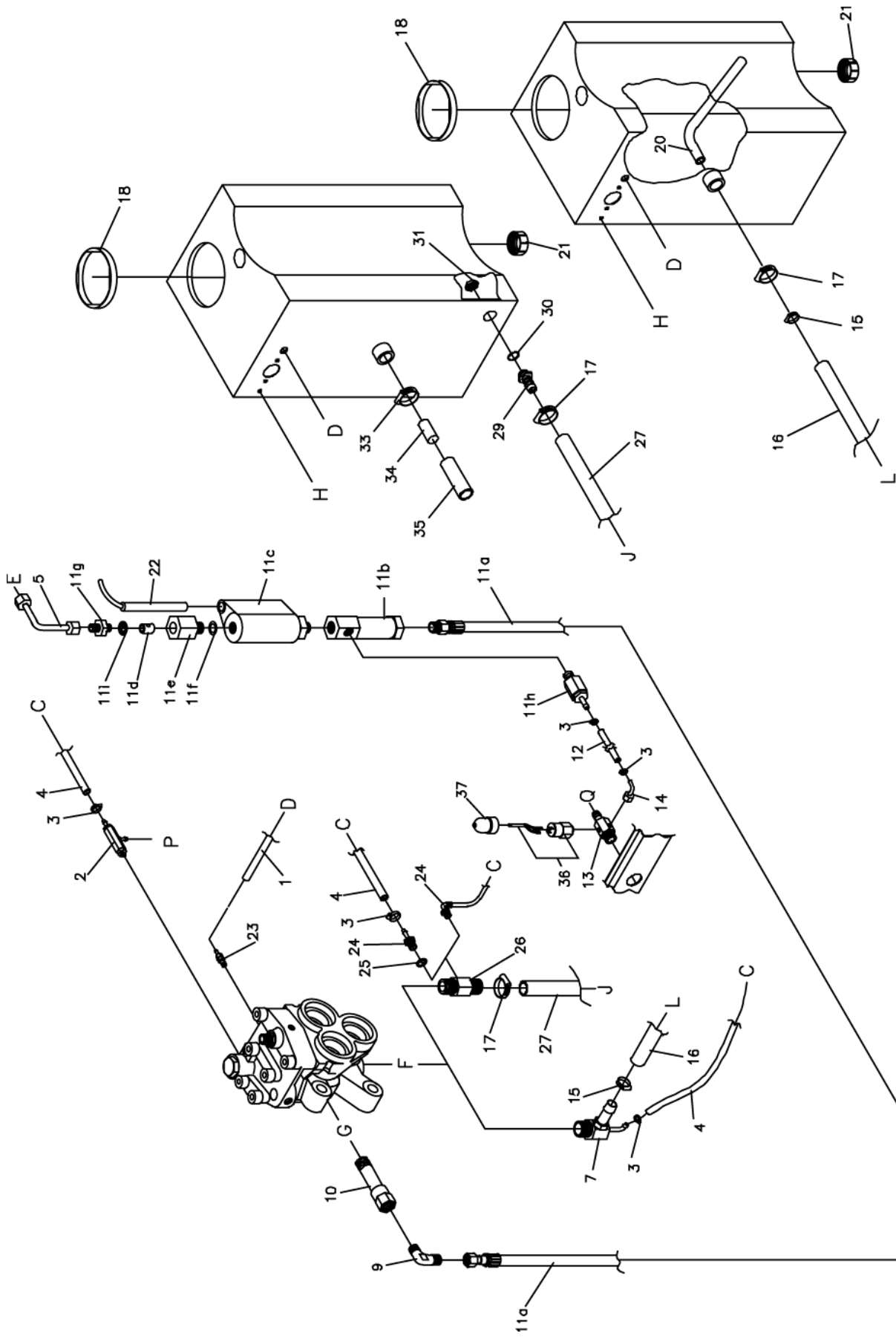

Vandtank / Flowstyring / Water tank / Flowstyring / wasserkasten / Stroemungskontrolle / Cuve deau / Conduite de flow

Pos.	Ref. no.	Beegnelse Description	Bezeichnung Description	6000 A	6400 A	6600 A
0	06120381	O-RING, 18,00X2,00 N70 O-RING, 18,00X2,00 N70	O-RING #18X2	2	2	2
0	06261302	O-RINGSKIT FOR TILGANGSSTUDS O-RING KIT FOR INLET SOCKET	KIT O-RING F. EINLASSSTUTZEN KIT JOINTSCCORD D'ENTREE CCORD D'ENTREE	1	1	1
0	06261919	VANDTANK, KPL. WATER TANK, CPL.	WASSERTANK KPL. CUVE A EAU, CPL.	1		1
0	06262036	VANDTANK, KPL. WATER TANK, CPL.	CUVE A EAU BAC		1	
01	06110596	SLANGE FOR OMLØB, 210 MM HOSE FOR BY-PASS, 210 MM	SHCLAUCH BY-PASS TUYAU BY-PASS N/G-3000	1	1	1
02	06211278	KEMIVENTIL HØJTRYK KPL. DETERGENT VALVE HIGH PRESS.CPL.	REINIGUNGSMITTELVENTIL HOCHDRUCK KPL. VANNE DETERGENT HP CPL.PRPRESS. COMPLETE	1	1	1
03	06110494	SPÆNDEBÅND, 10-12 RETAINING RING, 10-12	SCHLAUCHSCHELLE 8- FRETTE	4	4	4
04	06110493	KEMISLANGE, 1/4"X350 MM DETERGENT HOSE, 1/4"X350 MM	REINIGUNGSM.SCHLAUCH F. HOCHD.RM. G-6000 TUYAU DETERGENTPRESSION /PRESSION G6000	1	1	1
05	06261185	RØR FOR FLOWSWITCH KPL., G6000 PIPE FOR FLOW SWITCH CPL., G6000	ROHR F. STROEMUNGSWAECHTER KPL. TUYAU P.COMMUTATEUR DE FL FLOW COMPLET	1	1	1
07	06211279	FORDELERKLODS, KPL. DISTRIBUTOR BLOC, CPL.	VERTEILERKLOTZ REINIG.MIT.VENTIL KPL. BILLOT DISTRI.VAN.DET.G600NNE DE DET. COM	1	1	1
08	06030661	RØRPROP, 1/8" PLUG FOR PIPE, 1/8"	ROHRSTOPFEN BOUCHON	1	1	1
09	06030533	HYDRAULISK VINKELFORSKRUNING, 3/8"X12 HYDR.SCREWED CONNECTION, ANGLE, 3/8"X12	HYDR.VERSCHRAUBUNG,WINKEL 15-02/L12 TUYAU EN CUIVRE	1	1	1
10	06180970	AFSTANDSSTYKKE F.TOPSTYK DISTANCE NIPPLE, 22X55	DISTANZSNIPPEL RACCORD SORTIE POMPE HP	1	1	1
11A	06261246	SLANGE FOR FLOWSTYRING HOSE FOR FLOW CONTROL	SCHLAUCH F. STROEMUNGSKONTROLLE G-6000 TUYAU P.COND.DE FLOW G-60 G-6000	1	1	1
11A-	06211262	FLOWSTYRING KPL., 6000 FLOW CONTROL CPL., 6000	STROEMUNGSKONTROLLE KPL. CONDUITE DE FLOW COMPLETE	1	1	1
11B	06261301	KIT FOR TILGANGSSTUDS KIT FOR INLET SOCKET	KIT F. EINLASS-STUTZEN - HOCHDRUCK KIT RACCORD D'ENTREE HAUTE PRESSION	1	1	1
11C	06260669	FLOWSWITCH KOMPLET FLOW SWITCH CPL., 2000/6000/3000/MINIHOT	STROEMUNGSWAECHTER, KPL., G-2000/6000 CONTROLEUR DEBIT EAU (FLO	1	1	1
11C-	06261299	KIT FOR AFGANGSSTUDS KIT FOR OUTLET SOCKET	KIT F. AUSLASS-STUTZEN FLUSSOSTAT	1	1	1
11D	06180960	DRØVELVENTIL FOR FLOWST. THROTTLER VALVE FOR FLOW CONTROL, 11X11X18,8	DROSSELVENTIL F. STROEMUNGSKONTROLLE SOUPAPE RENIFL.P.COND.FLOONDUITE DE FLOW	1	1	1
11E	06180959	HUS FOR DRØVLEVENTIL, FLOWST., 27X35 HOUSING FOR THROTTLER VALVE, FLOW , 27X35	GEHAEUSE F. DROSSELVENTIL - STROEM.KONT. CORPS P.SOUP.RENIF.CON.FLTE CON. DE FLOW	1	1	1
11F	06120382	O-RING, 20,00X2,00 N70 O-RING, 20,00X2,00 N70	O-RING JOINT TORIQUE 20X2 G-5000	1	1	1
11G	06030037	HYDRAULIKFORSKR. 3/8-10/12 HYDRAULIC SCREWED CONNECTION, 3/8"-10/12	HYDRAULIKVERSCHRAUBUNG JOINT HYDRAULIQUE	1	1	1

Vandtank / Flowstyring / Water tank / Flowstyring / wasserkasten / Stroemungskontrolle / Cuve deau / Conduite de flow

Pos.	Ref. no.	Betegnelse Description	Bezeichnung Description	6000 A	6400 A	6600 A
11H	06211316	TILGANGSTUDS, KPL. INLET SOCKET, CPL.	RÜCKSCHLAGVENTIL KPL. CONTRE-VANNE=261538	1	1	1
11I	06120385	USITRING, USIT RING, 24X16,7X1.5	USITRING JOINT D'ETANCHEITE G-4000	1	1	1
12	06110432	KEMISLANGE, 1/4"X1000 MM DETERGENT HOSE, 1/4"X1000 MM	REINIGUNGSMITTELSCHLAUCH, INNEN TUYAU 800MM P/G6000	1	1	1
13	06180977	TILGANGSNIPPEL FLOWSTYRING, 29X92 INLET NIPPLE FLOW CONTROL, 29X92	EINLASSNIPPEL STROEMUNGSKONTROLLE G-6000 RACCORD ENTREE EAU G6000 DE FLOW G6000	1	1	1
14	06030304	VINKELNIPPEL, 6 X 1/4" ANGLE NIPPLE, 6 X 1/4"	WINKELSCHLAUCHNIPPEL TUYAU DE RACCORD EQUERRE	1	1	1
15	06110111	SPÆNDEBÅND, 13-20 RETAINING RING, 13-20	SCHLAUCHSCHELLE FRETTE	1	1	1
16	06110293	SUGESLANGE, 1/2X180 SUCTION HOSE, 1/2X180	SAUGSCHLAUCH 1/2X180 TUYAU D'ASPIRATION G 60000	1	1	1
18	06150098	LAG FOR DUNK, Ø100 COVER FOR TANK, Ø100	DECKEL FUER TANK ROT BOUCHON DE RESERVOIR ROUGE G-200	1	1	1
20	06050853	RØR FOR SUGESLANGE KEMIVENTIL, 240XØ12X1,5 PIPE FOR SUCTION HOSE, 240XØ12X1,5	ROHR F. SAUGSCHLAUCH REI.M.VENTIL G-6000 TUBE. DE DET. G6000 . DE DET. G6000	1	1	1
21	06150106	BUNDPROP BOTTOM CAP	BODENSTOPFEN F. WASSERKASTEN BOUCHON G 200 A EAU A EAU	1	1	1
22	06170121	REED-KONTAKT REED-SWITCH	REED-SCHALTER CONTACT REED	1	1	1
24	06181277	KEMISTUDS, 13X28 DETERGENT SOCKET, 13X28	CHEMIE STUTZEN RACCORD DE DETERGENT NG	1	1	1
25	06120497	USITRING, 1/8" USIT RING, 1/8"	JOINT USIT, 1/8"	1	1	1
26	06181435	FORDELERKLODS KEMIVENTIL KPL. DISTRIBUTOR BLOCK	BLOC DE DISTRIBUTEUR	1	1	1
27	06110634	SLANGE, 3/4X375 HOSE, 3/4X375	TUYAU, 3/4X375	1	1	1
28	06030696	RØRPROP, 1/2" PLUG FOR PIPE, 1/2"	ROHRSTOPFEN MESSING 1/2" EV 107B BOUCHON A VIS LAITON 1/2" EV 107B	1	1	1
29	06181335	SLANGESTUDS, 29X41 HOSE SOCKET, 29X41	SCHLAUCHSTUTZEN F. WASSERTANK RAC. DE TUYAU P.RES.D'EAU	1	1	1
30	06120158	O-RING, 24X2 O-RING, 24X2	O-RING F.WASSERFILTER JOINT TORIQUE	1	1	1
31	06030762	KONTRAMØTRIK, 1/2"X6 COUNTER NUT, 1/2"X6	GEGENMUTTER CONTRE ECROU 1/2 X 6	1	1	1
33	06110471	SPÆNDEBÅND, 14-32 RETAINING RING, 14-32	SCHLAUCHSCHELLE HS12 FRETTE	1	1	1
34	06280198	STIFT, Ø12X32 PIN, Ø12X32	POINTE POUR G 6400	1	1	1
35	06110640	SLANGE FOR PROP HOSE FOR PLUG	TUYAU P/CAPUCHON G 6400	1	1	1

Vandtank / Flowstyring / Water tank / Flowstyring / wasserkasten / Stroemungskontrolle / Cuve deau / Conduite de flow

Pos.	Ref. no.	Betegnelse Description	Bezeichnung Description	6000 A	6400 A	6600 A
36	06170152	PRESSOSTAT, 0,8 BAR PRESSOSTAT, 0,8 BAR	DRUCKSCHALTER PRESSOSTAT G 6000	1	1	1
37	06120312	GUMMIHÆTTE RUBBER CAP	GUMMIKAPPE CAPUCHON	1	1	1

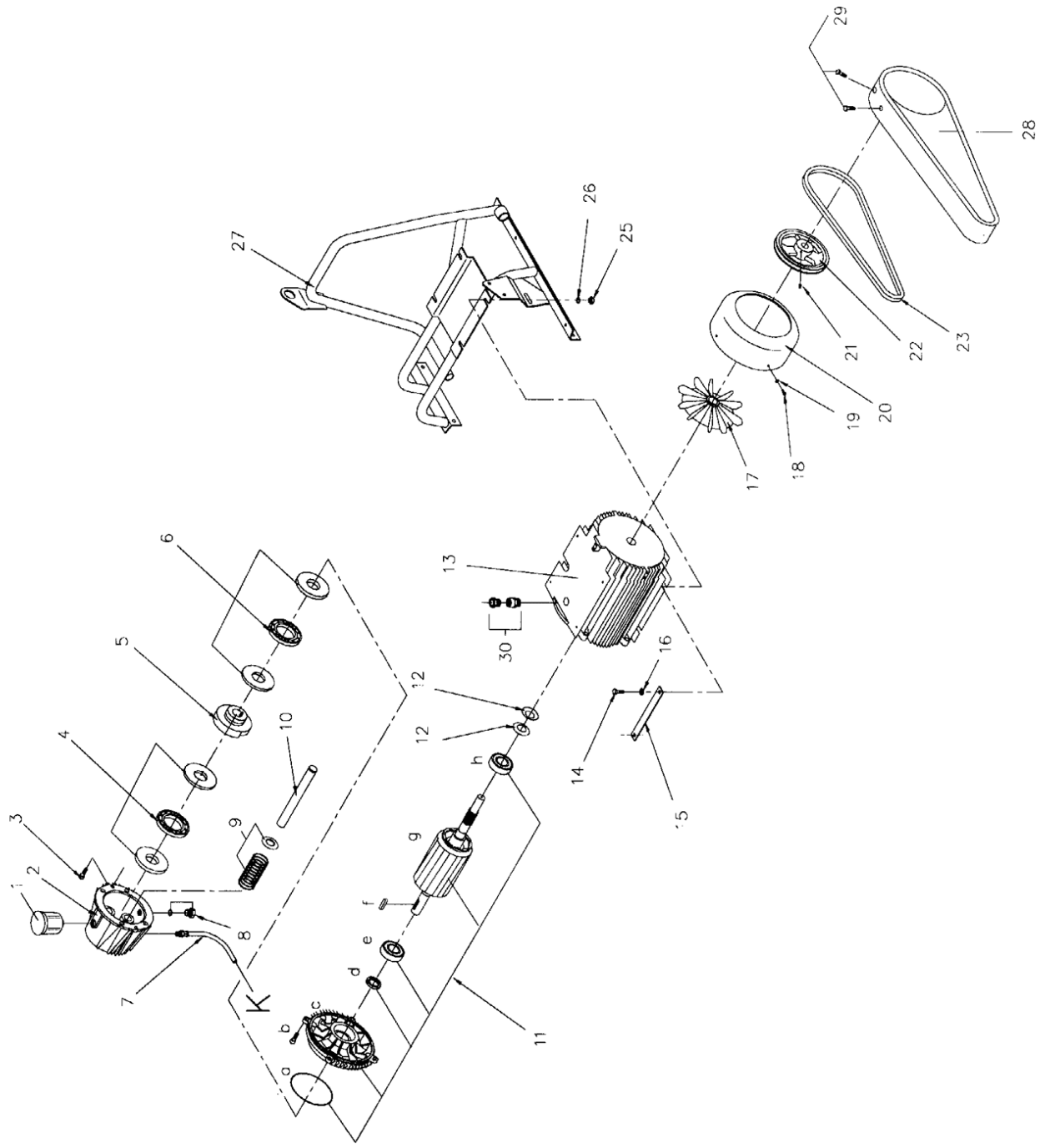

Motor 6000/6400/6600 / Motor 6000/6400/6600 / Moteur 6000/6400/6600

Pos.	Ref. no.	Betegnelse Description	Bezeichnung Description	6000 A	6400 A	6600 A
01	06150142	OLIEPÅFYLDNINGSGLAS OIL FILLING GLASS	OELAUFFUELLGLAS VERRE POUR REMPLISSAGE D"HUILE	1	1	1
02	06180757	STEMPELSTYR, 600 PISTON GUIDE, 600	KOLBENFUHRUNG GUIDE PISTON G 600	1	1	1
03	06070455	UNBRACO SKRUE, M8X25 ALLEN SCREW, M8X25	IMBUSSBOLZEN, GALV. BOULON GALV.	2	2	2
04	06260897	TRYKLEJEKIT PRESSURE BEARING KIT, G600	DRUCKLAGERKIT KIT ROULEMENT G 600-600/A-600/AL-POWER	1	1	1
05	06180743	SKRÅSKIVE, 7,11 CAM DISC, 7,11	BOGENSCHEIBE 7,11 DISQUE INCLINE 7,11 G5000	1		1
05	06180745	SKRÅSKIVE, 8,24 CAM DISC, 8,24	BOGENSCHEIBE DISQUE INCLINE 8,24		1	
05	06180746	SKRÅSKIVE, 8,24 CAM DISC, 8,24	BOGENSCHEIBE DISQUE INCLINE G 600	1	1	1
06	06260898	SKRÅKIVELEJEKIT CAM DISC BEARING KIT	BOGENSCHEIBELAGERKIT KIT ROULEMENT DISQUE G 60C. G600/ALPOWER	1	1	1
07	06261172	SLANGE F. OLIESLAMGLAS KP L.	SCHLAUCH F. OELSCHLAMMGLAS KPL. TUYAU POUR RECUPERATEUR D"HUILE CPL.	1	1	1
08	06260959	OLIEAFTAPNINGSPROP KPL., G100/G2000 DRAIN PLUG CPL., G100/G2000	OELABZAPFSTOPFEN, KPL. BOUCHON	1	1	1
09	06261037	FJEDERKIT SPRING KIT	FEDERKIT KIT RESSORT G600(3 PIECES)	1	1	1
1-3, 8-	06262265	STEMPELSTYR, KPL., 6400 PISTON GUIDE, CPL., 6400	GUIDE PISTON, CPL., 6400		1	
1-3, 8-	06262266	STEMPELSTYR, KPL., 66/6900A PISTON GUIDE, CPL., 66/6900A	GUIDE PISTON, CPL., 66/6900A	1		1
10	06260896	STEMPELKIT, STÅL 1 STK PISTON KIT, STEEL 1 PCS.	KOLBENKIT PISTON A L"UNITE G6000		3	
10	06261430	STEMPELKIT, KERAMIK 1 STK. PISTON KIT, CERAMIC 1 PCS.	KIT F. KOLBEN KPL. G-660/5000 KIT PISTONS (NOUVEAU) G-60/5000	3		3
11	06270204	SERVICEKIT ROTOR	SERVICEKIT ROTOR STATOR	1	1	1
11-13	06262448	MOTOR KPL KIT G6002 MOTOR CPL. KIT G6002	MOTOR KPL KIT G6002 MOTEUR CPL KIT G6002	1	1	1
11-13	06270200	EL-MOTOR, 3X230/400V 50HZ ELECTRIC MOTOR, 3X230/400V 50HZ	ELEKTRO-MOTOR G-6000 MOTEUR G-6000 V 50 HZ 00 V 50 HZ	1	1	1
11A	06120310	O-RING, 117X3 O-RING, 117X3	O-RING JOINT TORIQUE G 600	1	1	1
11B	06070455	UNBRACO SKRUE, M8X25 ALLEN SCREW, M8X25	IMBUSSBOLZEN, GALV. BOULON GALV.	4	4	4
11C	06180742	LEJEFLANGE BEARING FLANGE	LAGERFLANSCH D-LAGER BRIDE DE PALIER	1	1	1
11D	06120307	SIMMERRING, 30X47X7 SEALING RING, 30X47X7	OELDICHTUNGSRING JOINT SPI 30X47X7 G 600ILILE	1	1	1

Motor 6000/6400/6600 / Motor 6000/6400/6600 / Moteur 6000/6400/6600

Pos.	Ref. no.	Betegnelse Description	Bezeichnung Description	6000 A	6400 A	6600 A
11E	06140040	KUGLELEJE, 8X7X35 BALL BEARING , 8X7X35	KUGLELAGER 6206 ZZR.C3.L12 ROULEMENT 6206 G 600	1	1	1
11F	06280100	FEDER, 8X7X35 KEY , 8X7X35	FEDERFORM A DS96 CLAVETTE G-600	1	1	1
11G	06270176	ROTORAKSEL, G-6000 ROTOR AXLE, G-6000	ROTORWELLE ARBRE DE ROTOR	1	1	1
11H	06140039	KUGLELEJE BALL BEARING	KUGLELAGER 6205 ZZR.C3.L12 ROULEMENT 6205 G 600	1	1	1
12	06280103	TALLERKENF JEDER , 51,5X35, SPRING , 51,5X35,	TELLERFEDER 51,5X35X5X0,6X1,5 RESSORT G-600	2	2	2
13	06270161	STATORHUS M. STATOR , 3X230/400V 50 HZ STATOR HOUSING W. STATOR, 3X230/400V 50 HZ	STATORGEHAEUSE M. STATOR G600/POWER ENVELP .STATOR PLUS FOURNI	1	1	1
13	06270203	STATORHUS M. STATOR , 3X415V STATOR HOUSING W. STATOR, 3X415V	STATORGEHAEUSE M. STATOR CORPS DE STATOR AVEC STATOR	1	1	1
13	06270266	STATORHUS M/STATOR	STATORGEHAEUSE M/STATOR CORPS DE STATOR AVEC STATOR G-660	1	1	1
14	06070003	SÆTSKRUE, M8X20 SET SCREW, M8X20	SETZSCHRAUBE, GALV. VIS D'ARRET, GALVANISEE	4	4	4
15	06060978	FORSTÆRKNINGSPLADE , 182X22X3 REINFORCEMENT PLATE , 182X22X3	VERSTAERKUNGSPLATTE G-600 PLAQUE DE RENFORT G-600	1	1	1
16	06080018	STJERNESKIVE, M8 TOOTH LOCK WASHER, M8	FEDERTELLERSKEIBE, GALV. RONDELLE D'ETOILE	4	4	4
17	06270141	VENTILATOR FAN	VENTILATOR F. G-600 VENTILATEUR G 600	1	1	1
18	06070525	TAP TITE P/H, Ø5X8 TAP TITE P/H, Ø5X8	TAP TITE P/K PH TAP TITE	3	3	3
19	06080088	STJERNESKIVE, GALV., Ø5 TOOTH LOCK WASHER, GALV., Ø5	STERNESKEIBE, GALV. ROND A DENTS	3	3	3
20	06270178	VENTILATORSKÆRM FAN COVER	VENTILATORDECKEL PROTECTION DE SOUFFLANTEAABS NOIR 2,5MM	1	1	1
21	06070163	UNBRACO SKRUE, M8X12 ALLEN SCREW, M8X12	IMBUSSBOLZEN VIS PIVOT 8 X 12	2	2	2
22	06130188	KILEREMSKIVE, 140-1 V-BELT DISC, 140-1	KEILRIEHMENSKEIBE POULIEOIDALE OIDALE	1	1	1
23	06130193	KILEREM V-BELT	KEILRIEMEN COURROIE TRAPEZOIDALE G 6	1	1	1
25	06080038	MØTRIK, M8 NUT, M8	SELBSTSCHLIESSENDE MUTTER, GALV. ECROU	4	4	4
26	06080004	SPÆNDESKIVE, 8,4X17X1,6 TENSION DISC. 8,4X17X1,6	FEDERSKEIBE, GALV. RONDELLE	4	4	4
27	06211135	MOTORKONSOL KPL. MOTOR BRACKET CPL.	MOTORWAND KPL. CONSOLE DE MOTEUR CPL.	1	1	1
28	06240233	REMSKÆRM *D, G6000 BELT PULLEY *D, G6000	RIEMENSCHUTZPLATTE SCHWARTZ G-6000 TÜW CACHE COURROIEG-6000 T-W G-6000 TÜW	1		

Motor 6000/6400/6600 / Motor 6000/6400/6600 / Moteur 6000/6400/6600

6000 A 6400 A 6600 A

Pos.	Ref. no.	Betegnelse Description	Bezeichnung Description
29	06070436	SELVSKÆRENDE SKRUE, 1/2X10 SELF-TAPPING SCREW, 1/2X10	SCHRAUBE VIS 6 X 10
30	06160765	KABELGENNEMFØRING, 3X1,5 MM ² CABLE GROMMET, 3X1.5 MM ²	KABELDURCHFUEHRUNG PRESSE ETOUPE MOTEUR 6000

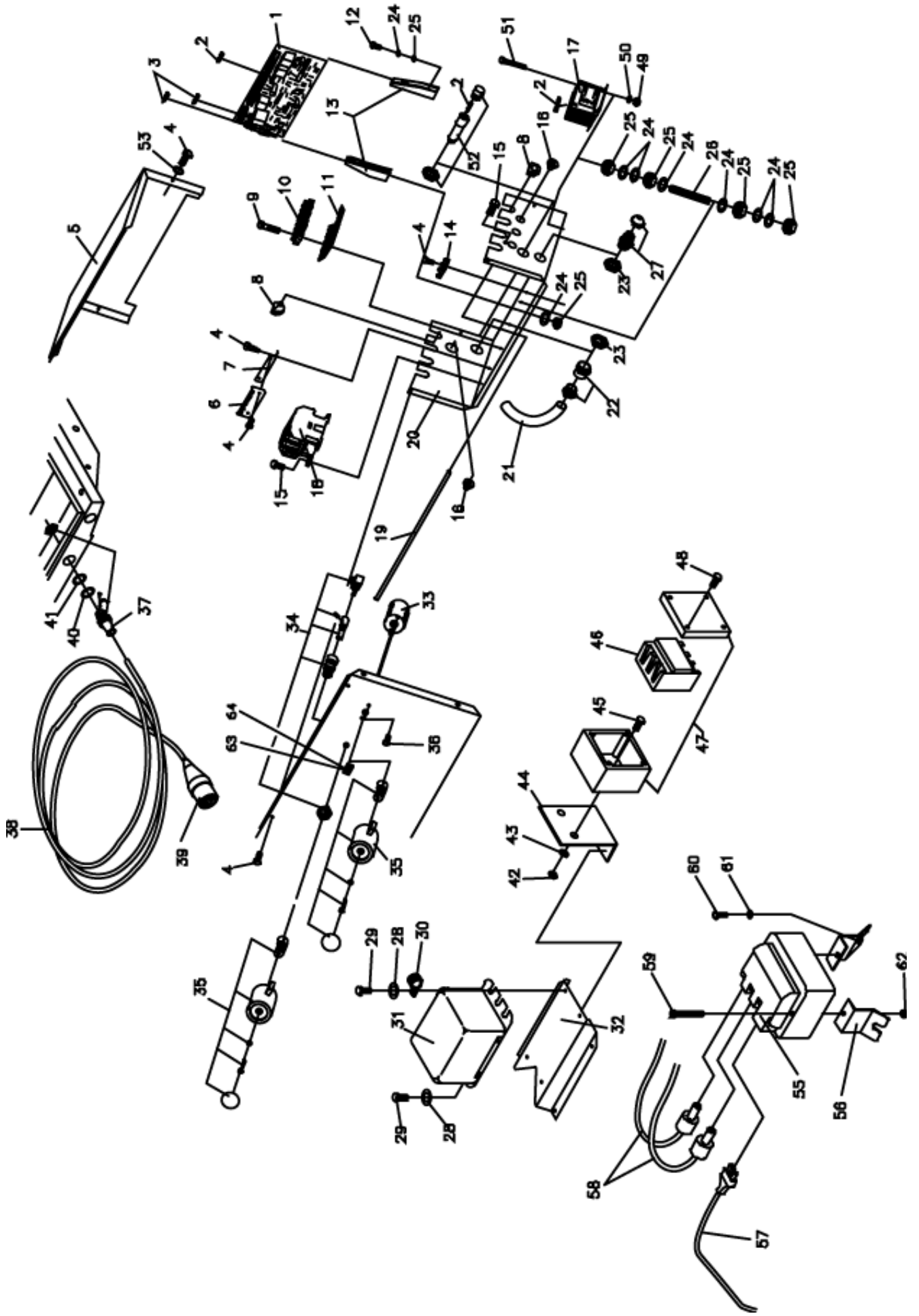

El-komponenter / Electric components / Elektrische komponente / Composantes électrique

Pos.	Ref. no.	Bezeichnung Description	6000 A	6400 A	6600 A
0	06170141	STIK FOR PRINTPLADE, 5 POL PLUG FOR CONTROL PRINT, 5 POL	1		
0	06170150	STIK FOR PRINTPLADE, 11 POL PLUG FOR CONTROL PRINT, 11 POL	1		
0	06170151	STIK FOR PRINTPLADE, 13 POL PLUG FOR CONTROL PRINT, 13 POL	1		
0	06170223	STIK FOR PRINTPLADE, 5 POL PLUG FOR CONTROL PRINT, 5 POL	1	1	1
0	06170224	STIK FOR PRINTPLADE, 11 POL PLUG FOR CONTROL PRINT, 11 POL	1	1	1
0	06170225	STIK FOR PRINTPLADE, 13 POL PLUG FOR CONTROL PRINT, 13 POL	1	1	1
01	06170177	STYREPRINT, 3X220/380 CONTROL PRINT, 3X220/380	1	1	1
02	06160067	FINSIKRING, 2 AMP. FUSE, 2 AMP.	2	2	2
02	06160890	SIKRING, 2A FUSE, 2A	2	2	2
03	06160889	SIKRING, 5A FUSE, 5A	2	2	2
03	06160911	SIKRING, 5A FUSE, 5A	2	2	2
04	06070355	SELVSKÆRENDE SKRUE, 3,5X9,5 SELF-TAPPING SCREW, 3,5X9,5	9	9	9
05	06061005	LAG FOR EL-BOX, 1X294X329 COVER FOR ELECTRIC BOX, 1X294X329	1	1	1
06	06170138	LYSDIODEPRINT, NG6000 LIGHT-EMITTING DIODE PRINT, NG6000	1	1	1
07	06060995	VINKELBESLAG FOR PRINT, 1X30X65 ANGLE FITTINGS FOR PRINT, 1X30X65	1	1	1
08	06120320	KABELGJENNEMFØRING, Ø25X11 CABLE GROMMET, Ø25X11	8	8	8
09	06070757	SKRUE, M3,5X16 SCREW, M3,5X16	2	2	2
10	06160838	KRONEMUFFE, 4,2X12 CROWN SOCKET, 4,2X12	1		
10	06160852	KRONEMUFFE, 2,5KV/9 CROWN SOCKET, 2,5KV/9	1	1	1
11	06160764	UNDERLAGSPLADE WASHER	1	1	1
12	06070058	SKRUE, M4X16 SCREW, M4X16	2	2	2
13	06170140	PRINTKORTHOLDER PRINT CARD HOLDER	2	2	2

El-komponenter / Electric components / Elektrische komponente / Composantes électrique

Pos.	Ref. no.	Betegnelse Description	Bezeichnung Description	6000 A	6400 A	6600 A
14	06160822	FLADSTIKFORDELER, 6,3 MM G6000 FLAT PLUG DISTRIBUTOR, 6,3 MM G6000	FLACHSTECHEVERTTEILER DISTRIBUTEUR DE PRISE DE COURANT	1	1	1
15	06070508	SELVSKÆRENDE SKRUE, 3,9X13 SELF-TAPPING SCREW, 3,9X13	SELBSTSCHNEIDENDE SCHRAUBE VIS	4	4	4
16	06120111	PAKÐASE, C 5-7 STUFFING BOX, C 5-7	STOPFBUCHSE PRESSE-ETOUPE CAOUTCHOUC	4	4	4
17	06160065	TRANSFORMER, 400V/24V TRANSFORMER, 400V/24V	TRANSFORMATOR LUEBCKE TRANSFORMATEUR	1	1	1
17	06160606	TRANSFORMER MED SIKRING, 3X200V TRANSFORMER W. FUSE, 3X200V	TRANSFORMATOR TRANSFORMATEUR	1	1	1
17	06160697	TRANSFORMER, 415V/24/15V 50HZ TRANSFORMER, 415V/24/15V 50HZ	TRANSFORMATOR ELEKTRODYN M/SICHER. TRANSFORMATEUR ELECTRODY. AFUSIBLE	1	1	1
17	06160939	TRANSFORMER, 230/400V TRANSFORMER, 230/400V	STEUERTRANSFORMER OHNE SICHERUNG TRANSFO HT-BT BI-VOLTAGE	1		
17	06170033	TRANSFORMER MED SIKRING, 230V/24V 50HZ TRANSFORMER W. FUSE, 230V/24V 50HZ	TRANSFORMATOR M. SICHERUNG TRANSFORMATEUR	1	1	1
18	06160463	KONTAKTOR, 25A 24V/50-60HZ CONTACTOR, 25A 24V/50-60HZ	SCHUETZ CI25 24 V 50/60 HZ CONTACTEUR CI25 24V 50HZ	1	1	1
18	06160464	KONTAKTOR CI15 24 V CONTACTOR, 16A 24V/50-60 HZ	SCHUETZ CI16 24 V 50/60 HZ CONTACTEUR CI15 3X400V	1	1	1
19	06050821	RØR FOR LEDNINGER, Ø6X1X325 PIPE FOR CABLES, Ø6X1X325	ROHR F. LEITUNGEN TUYAU POUR CABLES	1	1	1
20	06061004	ELKASSE, 1X198X605 ELECTRIC BOX, 1X198X605	ELEKTRO-SCHALTKASTEN, GALV. BOITE ELECTRIQUE GALV.	1	1	1
21	06160766	FLEX FOR LEDNINGER, 14X18X310 PLASTIC TUBING FOR CABLES, 14X18X310	PLASTIFLEX F. LEITUNGEN FLEX POUR CABLES	1	1	1
22	06160765	KABELGJENNEMFØRING, 3X1,5 MM2 CABLE GROMMET, 3X1,5 MM2	KABELDURCHFUEHRUNG PRESSE ETOUPE MOTEUR 6000	1	1	1
23	06160117	KONTRAMØTRIK, M16 COUNTER NUT, M16	GEGENMUTTER CONTRE-ECROU	2	2	2
24	06080046	STJERNESKIVE, M4 TOOTH LOCK WASHER, M4	STERNESCHIBE, GALV. RONDELLE	8	8	8
25	06080056	MØTRIK, M4 NUT, M4	MUTTER, GALV. ECROU	6	6	6
26	06070758	PINOLSKRUE, RUSTFRI	REITSTOCKSCHRAUBE, ROSTFREI VIS PIVOT	1	1	1
27	06160112	KABELGJENNEMFØRING CABLE GROMMET	KABELDURCHFUEHRUNG TRAVERSE DE CABLE	1	1	1
28	06080087	SPÆNDESKIVE, M8 TENSION DISC, M8	SCHEIBE, GALV. DISQUE	4	4	4
29	06070436	SELVSKÆRENDE SKRUE, 1/2X10 SELF-TAPPING SCREW, 1/2X10	SCHRAUBE VIS 6 X 10	4	4	4
30	06080182	KABELHOLDER, 400/415/440V CABLE HOLDER, 400/415/440V	ROHRHALTER 16 MM SUPPORT DE TUYAU 16 MM	1	1	1

El-komponenter / Electric components / Elektrische komponente / Composantes électrique

Pos.	Ref. no.	Betegnelse Description	Bezeichnung Description	6000 A	6400 A	6600 A
31	06230364	TÆNDTRANSFORMER, 3X200V IGNITION TRANSFORMER, 3X200V	TRANSFORMATEUR ALLUMAGE, 3X200V	1	1	1
31	06262346	TÆNDTRANSFORMER, 2X5 230V IGNITION TRANSFORMER, 2X5 230V	TRANSFORMATEUR ALLUMAGE, 2X5 230V	1	1	1
31	06262347	TÆNDTRANSFORMER, 2X5 400V IGNITION TRANSFORMER, 2X5 400V	TRANSFO ALLUMAGE 380V	1	1	1
31	06262348	TÆNDTRANSFORMER, 2X5 415V IGNITION TRANSFORMER, 2X5 415V	TRANSFORMATEUR ALLUMAGE, 2X5 415V	1	1	1
32	06061016	BESLAG FOR TÆNDTRAFØ, 1X208X223 SPD FITTINGS FOR IGNITION TRANSFO., 1X208X223 SPD	BESCHLAG F. ZUENDTRANSFORMATOR ARMATURE P. TRANSFORMATEUR D'ALLUMAGE	1	1	1
33	06160675	OMSKIFTER KOMPLET SWITCH CPL.	UMSCHALTER KPL. INTERRUPTEUR 1ETAGE	1	1	1
33	06160883	OMSKIFTER, 220V/380V SWITCH, 220V/380V	UMSCHALTER SALZER INVERSEUR SALZER	1		
34	06262344	POTENTIOMETER KPL POTENTIOMETER	POTENTIOMETRE	1	1	1
35	06260724	PLASTKNAPKIT BUTTON KIT, PLASTIC	KNOPFKIT, PLASTIK KIT BOUCHON PLASTIC (R.06	2	2	2
36	06070471	SELVSKÆRENDE SKRUE, 3.5X13 SELF-TAPPING SCREW, 3.5X13	SELBSTSCHNEIDENDE SCHRAUBE, P/K VIS CONIQUE TL	1	1	1
37	06261857	KABELGENNEMFØRINGSKIT, 3/4X1,5 CABLE GROMMET KIT, 3/4X1,5	KABELDURCHFØHRUNGSKIT KIT DE TRAVERSEE DE CABLE	1	1	1
37	06261858	KABELGENNEMFØRINGSKIT, 3/4X2,5 CABLE GROMMET KIT, 3/4X2,5	KABELDURCHFØHRUNGSKIT KIT DE TRAVERSEE DE CABLE, 3/4X2,5	1	1	1
37	06261859	KABELGENNEMFØRINGSKIT, 3/4X4,0 CABLE GROMMET KIT, 3/4X4,0	KIT DE TRAVERSEE DE CABLE, 3/4X4,0	1	1	1
38	06160708	TILGANGSKABEL GUMMI, 4X1.5X10000 INLET CABLE RUBBER, 4X1.5X10000	HAUPTKABEL GUMMI CABLE ALIMENTATION 10M	1	1	1
38	06160709	TILGANGSKABEL GUMMI, 4X2.5X10000 INLET CABLE RUBBER, 4X2.5X10000	HAUPTKABEL GUMMI CABLE PRINCIPAL EN CAOUTCHOUC	1	1	1
38	06160841	TILGANGSKABEL GUMMI, 4X4.0X8000 INLET CABLE RUBBER, 4X4.0X8000	EINLASSKABEL GUMMI CABLE ELECTRIQUE PR G 880HOUCC	1		
39	06160399	CEE INDUSTRISTRISK SPOL, 16A "AUS" PLUG, 10 A	ELEKTROSTECKER CT 516/6H 5-POLIG *N*S*SF PRISE ELECTRIQUE CT 516/6H 5 POLAI.	1		
40	06080208	STJERNESKIVE, M20 TOOTH LOCK WASHER, M20	STERNESKIBE GALV. RONDELLE A DENTS GALV. TYPE I M20	1		
41	06080181	SKIVE, 26X21X,08 WASHER, 26X21X,08	SCHEIBE 52010220 DISQUE	1		
42	06080084	MØTRIK, M5 NUT, M5	MUTTER, GALV. ECROU GALVANISE	2		
43	06080162	FJEDERSKIVE, M5 SPRING WASHER, M5	FEDERSKIBE DISQUE	2		
44	06061115	BESLAG FOR HFI-RELÆ, *SF FITTINGS FOR HFI-RELAY, *SF	BESCHLAG F. HFI G-6000 FINNLAND ARMATURE POUR HFI G-6000 SF	1		

El-komponenter / Electric components / Elektrische komponente / Composantes électrique

Pos.	Ref. no.	Betegnelse Description	Bezeichnung Description	6000 A	6400 A	6600 A
45	06070358	SKRUE, 5X16 SCREW, 5X16	SCHRAUBE P/H 5X16 HFC 9041 VIS	2		
46	06160726	HFI-RELÆ, *FIN HFI-RELAY, *FIN	HOCHEMPF. ERDSTROMSCH. SIEMENS FI-G HFI RELAIS SIEMENS FI-APPROUVE	1		
47	06160727	MONTERINGSKASSE, *FIN MOUNTING BOX, *FIN	MONTERINGSKASTEN BOITE DE MONTAGE 5ST1311 M36 SIEMENS	1		
48	06070761	SKRUE P/H SELVSKÆRENDE	SCHRAUBE P/H SELBSTSCHNEIDENDE VIS CONIQUE	4		
49	06080055	MØTRIK, M3 NUT, M3	MUTTER GALV. ECROU GALVANISE	2		
50	06080158	STJERNESKIVE, M3 TOOTH LOCK WASHER, M3	STERNSCHEIBE TYP I M3 RONDELLE A DENTS TYPE I M3	2		
51	06070760	SKRUE P/H M3X55	SCHRAUBE P/H M3X55 VIS	2		
52	06160840	SIKRINGSHOLDER HOLDER FOR FUSE	SICHERUNGSHALTER M. VORSATZGERAETI/KAPPE PORTE-FUSIBLE A/ADAPTEUR+COLLIER	1		
53	06080108	SKIVE, M4 WASHER, M4	SCHEIBE, GALV. DISQUE GALV.	2	2	2
63	06262331	KIT TIMETÆLLER, 600/6000 SYS KIT F. HOUR METRE, 600/6000 SYS	KIT P. COMPTEUR HORAIRE, 600/6000 SYS		1	1
64	06120566	PAKNING GASKET	JOINT		1	1

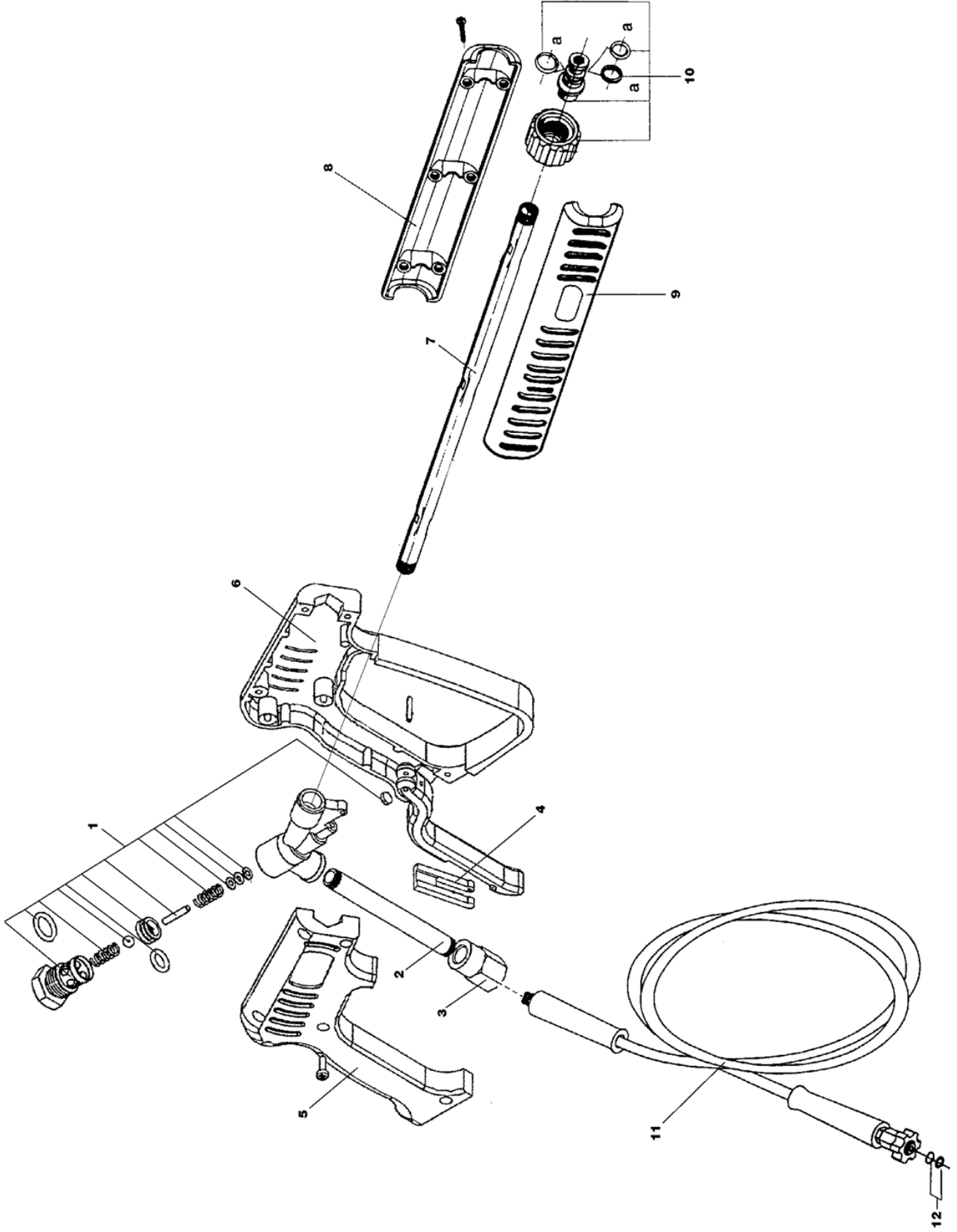

Pistol 98 / Pistol 98 / Pistole 98 / Pistolet 98

Pos.	Ref. no.	Betegnelse Description	Bezeichnung Description	6000 A	6400 A	6600 A
0	06290028	PISTOL ASTRA 320 3/8 PISTOL, 98	PISTOLE ASTRA 320 PISTOLET MRM320=290113	1	1	1
01	06261543	SERVICEKIT F. PISTOL MTM SERVICE KIT FOR PISTOL , MTM	KIT F. PISTOLE MTM KIT DE SERVICE P.PISTOLET	1	1	1
02	06050981	TILGANGSRØR INLET PIPE	EINLASSROHR F. PISTOL TUBE D'ENTREE PISTOLET	1	1	1
04	06200384	SIKKERHEDSPAL SAFETY LOCK	SPERRVORRICHTUNG ARRET DE SURETE MTM	1	1	1
05	06200420	PISTOLKROP PISTOL HOUSING	PISTOLKÖRPER RECHTS CORPS DE PISTOLET	1	1	1
06	06200421	PISTOLKROP PISTOL HOUSING	PISTOLKÖRPER LINKS CORPS DE PISTOLET	1	1	1
07	06050980	FORRØR FOR PISTOL FRONT PIPE FOR PISTOL	VORDERROHR F. PISTOLE TUBE	1	1	1
08	06200423	KAPPE VENSTRE CAP LEFT	KAPPE FÜR FOHRROHR LINKS CARTER DE PISTOLET GAUCHE	1	1	1
09	06200422	KAPPE - HØJRE CAP, RIGHT	KAPPE FÜR VORROHR RECHTS CARTER DE PISTOLET DROIT	1	1	1
10	06261588	SKRUEKOBLING FOR PISTOL SCREW COUPLING FOR PISTOL	SCHRAUBENKUPPLUNG F. PISTOLE RACCORD D'ACCROUPEMENT P.OLETS	1	1	1
10A	06261547	PAKNINGSKIT F. SKRUEKOBL. GASKET KIT FOR SCREW COUPLING	SCHRAUBKUPPLUNG KIT P. JOINTS TORIQUES RACC.A.VIS	1	1	1
11	06110476	HØJTRYKSSLANGE, DN8X8M HIGH PRESSURE HOSE, DN8X8M	HOCHDRUCKSCHLAUCH M. SCHRAUBENKUPPLUNGEN TUYAU H.P. A/RAC.A VIS/R.ER A/RAC. A VIS	1	1	1
12	06260936	PAKNINGSKIT F. SKRUEKOB. GASKET KIT FOR SCREW COUPLING	DICHTUNGSKIT F. SCHRAUBENKUPPLUNG KIT JOINT RACCORD VIS VIS	1	1	1

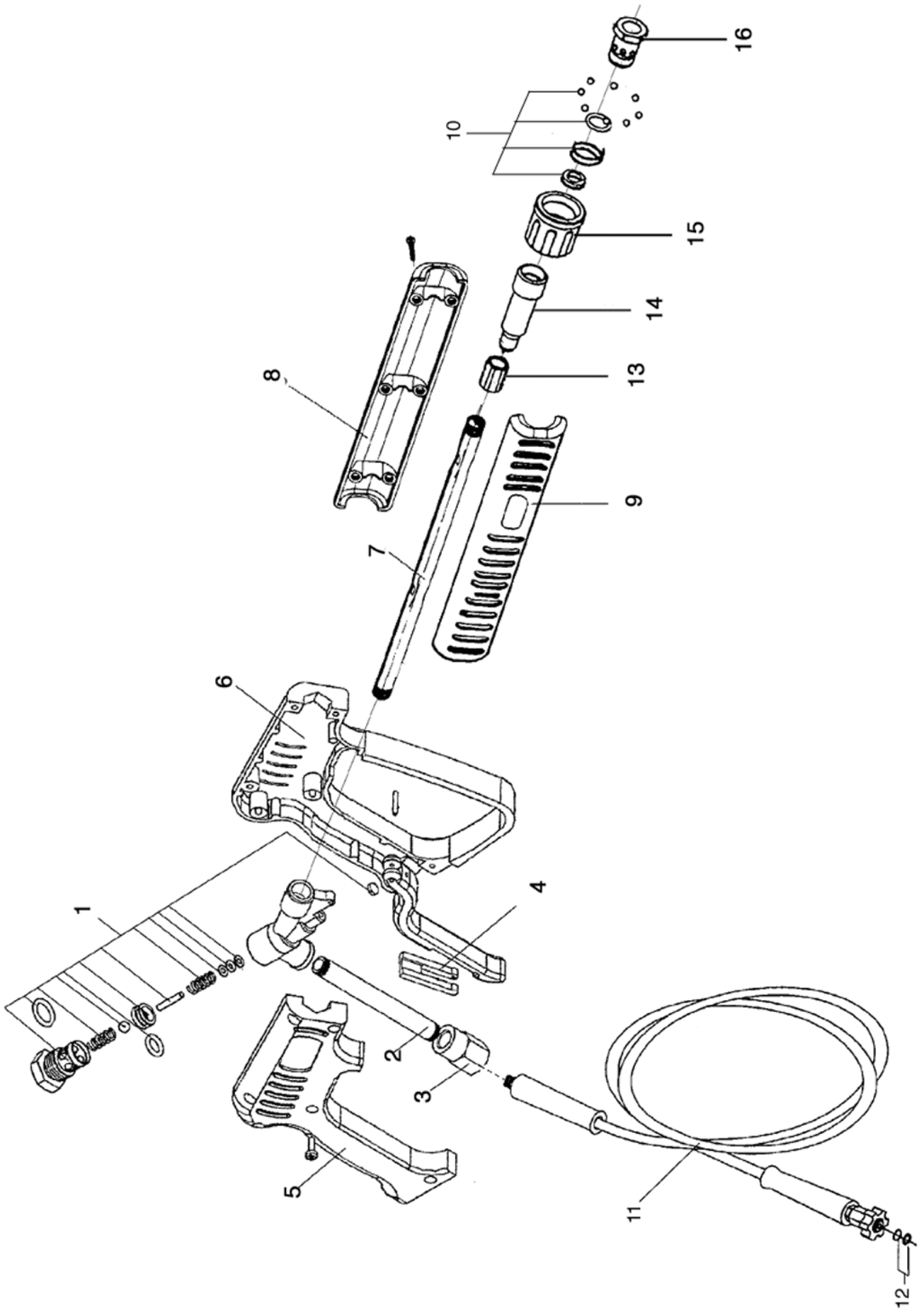

Pistol / Pistol / Pistole / Pistolet

Pos.	Ref. no.	Betegnelse Description	Bezeichnung Description	6000 A	6400 A	6600 A
0	06290080	PISTOL LANG M. QUICK PISTOL WITH QUICK COUPLING	PISTOLET 3/8 EME	1	1	1
01	06261543	SERVICEKIT F. PISTOL MTM SERVICE KIT FOR PISTOL , MTM	KIT F. PISTOLE MTM KIT DE SERVICE P.PISTOLET	1	1	1
02	06050981	TILGANGSRØR INLET PIPE	EINLASSROHR F. PISTOL TUBE D'ENTREE PISTOLET	1	1	1
04	06200384	SIKKERHEDSPAL SAFETY LOCK	SPERRVORRICHTUNG ARRET DE SURETE MTM	1	1	1
05	06200420	PISTOLKROP PISTOL HOUSING	PISTOLKÖRPER RECHTS CORPS DE PISTOLET	1	1	1
06	06200421	PISTOLKROP PISTOL HOUSING	PISTOLKÖRPER LINKS CORPS DE PISTOLET	1	1	1
07	06051045	FORRØR FOR PISTOL FRONT PIPE FOR PISTOL	TUBE AVANT PISTOLET290080	1	1	1
08	06200525	KAPPE CAP	CACHE TUBE PISTOLET290080	1	1	1
09	06200524	KAPPE CAP	CACHE TUBE PISTOLET290080	1	1	1
10	06262246	KIT FOR LYNKOBLING KIT FOR QUICK COUPLING	KIT JOINTS RACCORD RAPIDE	1	1	1
11	06110200	HØJTRYKSSLANG DN10X10M HIGH PRESSURE HOSE, 3/8"X3/8" NIPPLE, Ø10 MM 10 M	HOCHDRUCKSCHLAUCH FLEXIB.HP 10M-DIAMETRE 10	1	1	1
12	06260936	PAKNINGSKIT F. SKRUEKOB. GASKET KIT FOR SCREW COUPLING	DICHTUNGSKIT F. SCHRAUBENKUPPLUNG KIT JOINT RACCORD VIS VIS	1	1	1
13	06262287	MUFFE, 1/4"-1/4" SOCKET, 1/4"-1/4"	MANCHON P/PISTOLET 290080	1	1	1
14	06262286	KOBLING COUPLING	RACCORD VIS P/PISTOLET	1	1	1
15	06262284	OMLØBER COUPLING NUT	ECROU D/RACCORD P/PISTOLE	1	1	1
16	06262285	KOBLING COUPLING	RACCORD P/PISTOLET 290080	1	1	1

Spulerør / Lances / Lanzen / Lance

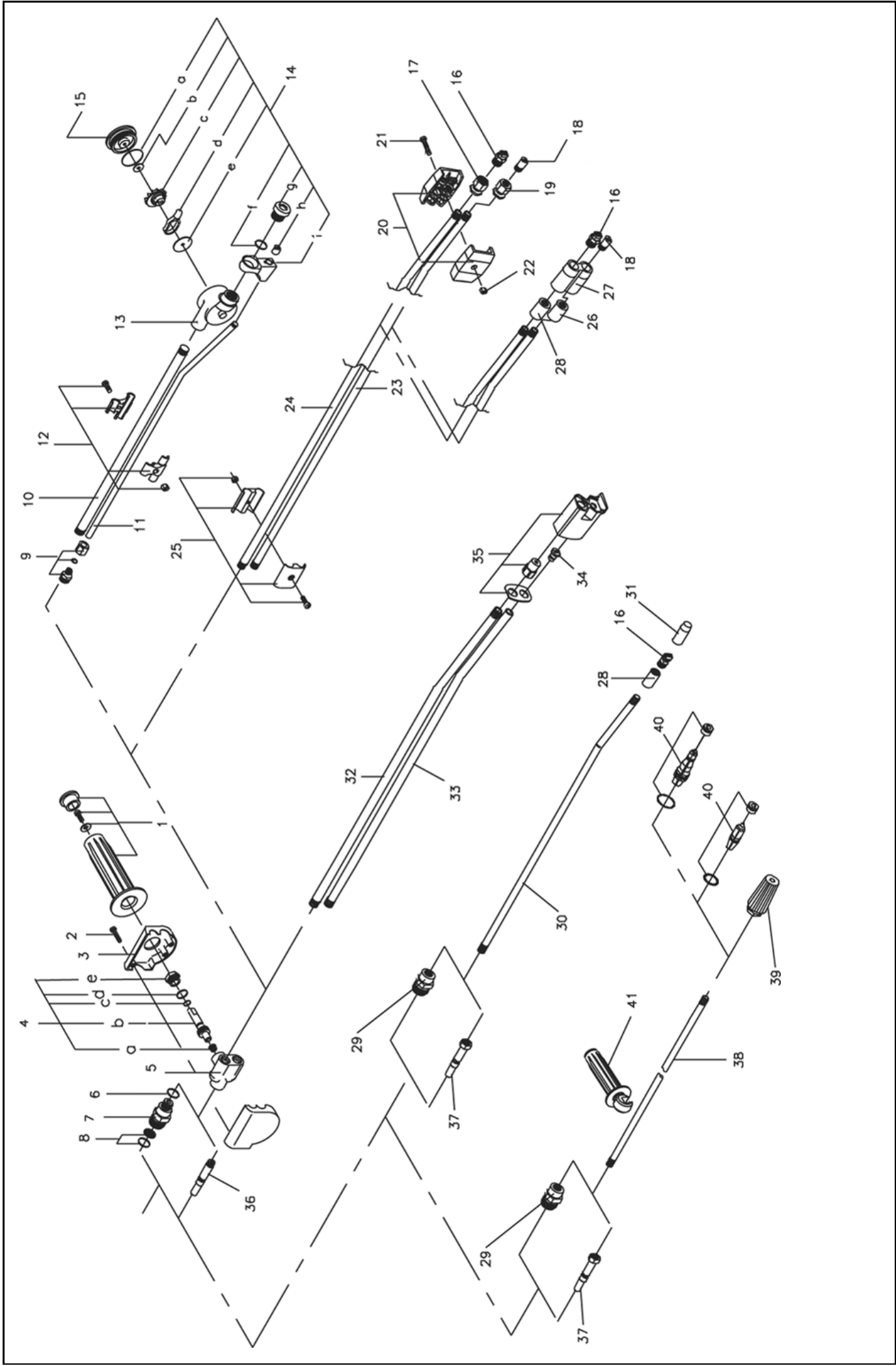

Spulerør / Lances / Lanzen / Lance

Pos.	Ref. no.	Betegnelse Description	Bezeichnung Description	6000 A	6400 A	6600 A
01	06260232	HANDTAGSKIT F. SPULERØR HANDLE KIT	HANDGRIFFKIT F. DOPPELLANZE KIT SERVICE AVEC POIGNEENNE DOUBLE	1	1	1
02	06070479	SKRUE, 4X20 SCREW, 4X20	SCHNEIDSCHRAUBE, SCHWARZZINK VIS	3	3	3
03	06200097	PYNTEDÆKSEL F. VENTILHUS COVER F. VALVE HOUSING	STAUWKAPPE F. VENTILGEHAE COUVERCLEOR. D. VAN OR. D. VAN	1	1	1
04	06260860	VENTILSPINDEL KIT VALVE SPINDLE KIT	VENTILSPINDELKIT F. DRUCKREGELUNG KIT REGLAGE PRESSION DOUBLEGL. PRES.	1	1	1
04C	06120006	O-RING, 6,75X1,78 O-RING, 6,75X1,78	O-RING JOINT TORIQUE MAT 4470	1	1	1
04D	06120010	O-RING, 13,1X1,6 O-RING, 13,1X1,6	O-RING JOINT TORIQUE MAT 4470	1	1	1
04E	06190245	MØTRIK NUT	MUTTER F. VENTIL ECROU POUR VANNE DOUB.LAN	1	1	1
05	06211078	VENTILHUS VALVE HOUSING	VENTILGEHAEUSE, KPL. CULASSE LANCE DOUBLE ET	1	1	1
06	06120188	O-RING, 10X2 O-RING, 10X2	O-RING JOINT TORIQUE	1	1	1
07	06030484	SKRUEKOBLING 1/4 UDV. SCREW COUPLING ROTATABLE, 1/4"	SCHR.KUPPLUNG DREHBAR F.DOPPELLANZE ACCOUPL. VIS TOURNANT DBL LANCE DOUBLE	1	1	1
08	06100332	FILTER FOR TURBO LASER FILTER FOR TURBO LASER	FILTER F. TURBO LASER M. O-RING FILTRE TURBO LASER	1	1	1
08A	06120139	O-RING, 10X1 O-RING, 10X1	O-RING JOINT SPY JET	1	1	1
09	06030527	BRYSTNIPPEL, 8X1/4" BREAST NIPPLE, 8X1/4"	GEWINDESTUECK RACCORD	1		1
0A	06261109	TURBO-LASER 600 MM TURBO LASER W. PRES. REG. - SCREW - 600 MM, 7.0	TURBO LASER TURBO-LASER 600MM G-600P/	1		1
0A	06262067	TURBO-LASER 600MM QUICK TURBO LASER W. PRES. REG. - QUICK - 600 MM, 7.0	TURBO-LASER 600MM RAPIDE	1		1
0B	06260758	DOBBELT SPULERØR 600MM EXCL.TRYKDYSE DOUBLE LANCE - PRES. REG.- SCREW -600 MM,	DOPPELLANZE DOUBLE LANCE 600MM	1	1	1
0B	06262063	DOBB.SPULERØR 600MM QUICK DOUBLE LANCE - PRES. REG.- QUICK-600 MM,	LANCE DOUBLE RAPIDE, 600M	1	1	1
0C	06260382	ENKELT SPULERØR 600 MM SINGLE LANCE - SCREW - 600 MM, EXCL.NOZ	EINZELLANZE LANCE SIMPLE 600 MM	1	1	1
0C	06262059	ENK.SPULERØR 600MM QUICK SINGLE LANCE - QUICK - 600 MM, EXCL.NOZ	LANCE SIMPLE RAPIDE, 600M	1	1	1
0D	06261957	SPECTRUM 600MM U/TRYKDYSE SPECTRUM W. PRES. REG. - SCREW - 600 MM,	SPECTRUM OHNE DÜSE - 600 MM SPECTRUM SANS GICLEUR - 600 MM	1	1	1
0D	06261992	SPECTRUM M/ TRYKREG. - SKRUE - 600 MM, 170 SPECTRUM W. PRES. REG. - SCREW - 650 MM, 170	SPECTRUM DÜSE LANCE SPECTRUM	1		1
0D	06261993	SPECTRUM M/ TRYKREG. - SKRUE - 600 MM, 190 SPECTRUM W. PRES. REG. - SCREW - 650 MM, 190	SPECTRUM DÜSE LANCE SPECTRUM			1

Spulerør / Lances / Lanzen / Lance

Pos.	Ref. no.	Betegnelse Description	Bezeichnung Description	6000 A	6400 A	6600 A
0D	06262095	SPECTRUM 600/Ø7.0MM QUICK SPECTRUM W. PRES. REG. - QUICK - 600 MM, 170	LANCE SPECTRUM 600/Ø7.0MM	1		1
0D	06262096	SPECTRUM M/ TRYKREG. - LYN - 600 MM, 190 SPECTRUM W. PRES. REG. - QUICK - 600 MM, 190	LANCE SPECTRUM 600/Ø9.0MM		1	
0D	06262253	SPECTRUM 600 U.DYSE QUICK SPECTRUM W. PRES. REG. - QUICK - 600 MM,	LANCE SPECTRUM R. R-S/GICL	1	1	1
0E	06262117	ROTO JET LANCE 070 ROTO JET - SCREW - 600 MM, 7.0	LANCE ROTO JET 070	1		1
0E	06262118	ROTO JET LANCE 090 ROTO JET - SCREW - 600 MM, 9.0	LANCE ROTO JET 090		1	
0E	06262128	ROTO JET M/ LYN - 600 MM, 7.0 ROTO JET - QUICK - 600 MM, 7.0	LANCE ROTO JET RAPIDE 070	1		1
0E	06262129	ROTO JET M/ LYN - 600 MM, 9.0 ROTO JET - QUICK - 600 MM, 9.0	LANCE ROTO JET RAPIDE 090		1	
10	06050841	SPULERØR LIGE, Ø13X1,5X586 LANCE STRAIGHT, Ø13X1,5X586	LANGE GERADE TURBO LASER LANCE DROITE TURBO LASER	1		1
11	06050842	KEMIRØR 15 GR. BUK , Ø8X1X622 DETERGENT PIPE 15 DEG., Ø8X1X622	REI.MITTLEROHR 15 GR. VERB. F. T. L. TUYAU POUR LANCESER, 15 DSER, 15 DEGRES	1		1
12	06261130	BESLAG FOR TURBO LASER FITTINGS FOR TURBO LASER	BESCHLAG F. TURBO LASER ROHR ARMATURE POUR TURBO LASER TUYAU	1		1
13	06261288	TURBO LASER HUS, Ø3,6 MIN 720 L TURBO LASER HOUSING, Ø3,6 MIN 720 L	GEHAUSE F. TURBO LASER CORPS P.TURBO LASER 3E GE COMPLET	1		
14	06261152	TURBO LASER KIT, 7.0 TURBO LASER KIT, 7.0	SERVICEKIT F. TURBO LASER KIT REP. TURBO LASER G 60ASER	1		1
14A	06120544	O-RING, 36.0X1,78 O-RING, 36.0X1,78	JOINT TORIQUE	1		1
14F	06120282	O-RING, 14X1,78 O-RING, 14X1,78	O-RING JOINT TORIQUE 14 X 1,78	1		1
14H	06180533	DYSE, Ø10X12 NOZZLE, Ø10X12	DUESE GICLEUR DIA. 10X12	1		1
15	06180936	LÅG FOR TURBO LASER COVER FOR TURBO LASER	DECKEL F. TURBO LASER, BEARBEITET COUVER.P.TURBO LASER FACOR, FACONNE	1		1
16	06090207	DYSE HÆRDET 1/4-1507 FLAT JET NOZZLE 15°.7	DUESE, GEHAERTET, ROSTFREI GICLEUR DURCI 1/4MEG 1507	1		1
17	06180780	DYSEHOLDER, 17X20 NOZZLE HOLDER, 17X20	DUESENHALTER F/HOCHDRUCKDUESE SUPPORT DE GICLEUR H.P.EUEUR H.P.	1	1	1
18	06180779	KEMIDYSE, Ø10X22 DETERGENT NOZZLE, Ø10X22	REINIGUNGSMITTELDUESE GICLEUR DETERGENT	1	1	1
19	06180781	DYSEHOLDER FOR KEMI, 17X20 NOZZLE HOLDER FOR DETERGENTS, 17X20	DUESENHALTER F/REINIGUNGSMITTEL SUPPORT DE GICLEUR DETERGRGENT	1	1	1
20	06200226	DYSEBESKYTTER NOZZLE PROTECTION, PLASTIC	DUESENSCHUTZ KUNSTSTOFF PROTECTION GICLEUR PLASTI PLASTIQUE	2	2	2
21	06070497	SKRUE, 5X22 SCREW, 5X22	SCHRAUBE, ROSTFREI, Z/K VIS C/H INOX	1	1	1

Spulerør / Lances / Lanzen / Lance

Pos.	Ref. no.	Betegnelse Description	Bezeichnung Description	6000 A	6400 A	6600 A
22	06080123	MØTRIK, M5 NUT, M5	MUTTER, ROSTFREI RONDELLE	1	1	1
23	06050941	KEMI-RØR, RUSTFRI, Ø13X1,5X591 DETERGENT PIPE, STAINLESS, Ø13X1,5X591	DOPPELLANZE TUBE DE LANCE BP	1	1	1
24	06050940	SPULERØR, RUSTFRI, Ø13X1,5X596 LANCE, STAINLESS, Ø13X1,5X596	DOPPELLANZE TUBE DE LANCE HP	1	1	1
25	06260537	BESLAG F. DOBB. SPULERØR FITTINGS FOR DOUBLE LANCE	BESCHLAG F/DOPPELLANZE TURBO ENTRETOISE LANCE TURBOE TE TURBO	1	1	1
26	06181232	DYSEHOLDER FOR KEMI, Ø18X26 NOZZLE HOLDER FOR DETERGENTS, Ø18X26	DUESEHALTER F. REINIGUNGSMITTELDUESE SUPPORT GICLEUR POUR DETER DE DETERGENT	1	1	1
27	06200374	DYSEBESKYTTER DOBBELT NOZZLE PROTECTION, PLASTIC, DOBBLE	DUESESCHUTZ - DOPPELT PROTECT.PLAST.GICLEUR LAN	1	1	1
28	06030643	MUFFE FOR SPULERØR, Ø10 SOCKET FOR LANCE, Ø10	MUFFE F. LANZE MANCHON POUR LANCE INOX	1	1	1
28	06181233	DYSEHOLDER , Ø18X26 NOZZLE HOLDER , Ø18X26	DUESEHALTER F. HOCHDRUCKSDUESE SUPPORT GICLEUR HAUTE PRE	1	1	1
29	06030485	SKRUEKOBLING, 1/4" INDV. SCREW COUPLING, 1/4"	SCHRAUBENKUPPLUNG, NICHT DREHBAR ACCOUPL. VIS 1/4 INT.NT NT	1	1	1
30	06050116	SPULERØR, RUSTFRI, Ø13X586 LANCE, STAINLESS, Ø13X586	LANZE, ROSTFREI LANCE INOX DIAM. 13X596	1	1	1
31	06200375	DYSEBESKYTTER ENKELT NOZZLE PROTECTION, PLASTIC, SINGLE	DUESESCHUTZ PROTECT.PLAST.GICLEUR LAN	1	1	1
35	06261968	SPECTRUM KIT, 150 SPECTRUM KIT, 150	SPECTRUM KIT KIT SPECTRUM 690/6900	1		1
35	06261971	SPECTRUM KIT, 190 SPECTRUM KIT, 190	SPECTRUM KIT KIT SPECTRUM 640/6400		1	
36	06030649	LYNKOBLING 1/4 UDV. QUICK COUPLING, 1/4"	SCHNELLKUPPLUNG RACCORD RAPIDE	1	1	1
37	06030827	NIPPEL QUICK-1/4" INDV. NIPPLE, 1/4"	RACCORD RAPIDE 1/4" INTER	1	1	1
38	06050841	SPULERØR LIGE, Ø13X1,5X586 LANCE STRAIGHT, Ø13X1,5X586	LANZE GERADE TURBO LASER LANCE DROITE TURBO LASER	1	1	1
39	06262139	ROTO JET DYSE KPL., 7.0 ROTO JET NOZZLE CPL., 7.0	GICLEUR ROTO CPL. 7.0	1		1
39	06262140	ROTO JET DYSE KPL., 9.0 ROTO JET NOZZLE CPL., 9.0	GICLEUR ROTO CPL. 9.0		1	
40	06262226	ROTO DYSE KIT 070 ROTO JET NOZZLE KIT, 7.0	KIT POUR GICLEUR ROTO 070	1		1
40	06262227	ROTO DYSE KIT, 9.0 ROTO JET NOZZLE KIT, 9.0	KIT POUR GICLEUR ROTO 090		1	
41	06260365	HANDGREB TIL ROT. BØRSTER OG ENKELT LANSERØR, HANDLE FOR ROTATING BRUSHES AND SINGLE	HANDGRIFF POIGNEE DE MAINTIEN LANCE	1	1	1