

03K  
C3KA  
3000C

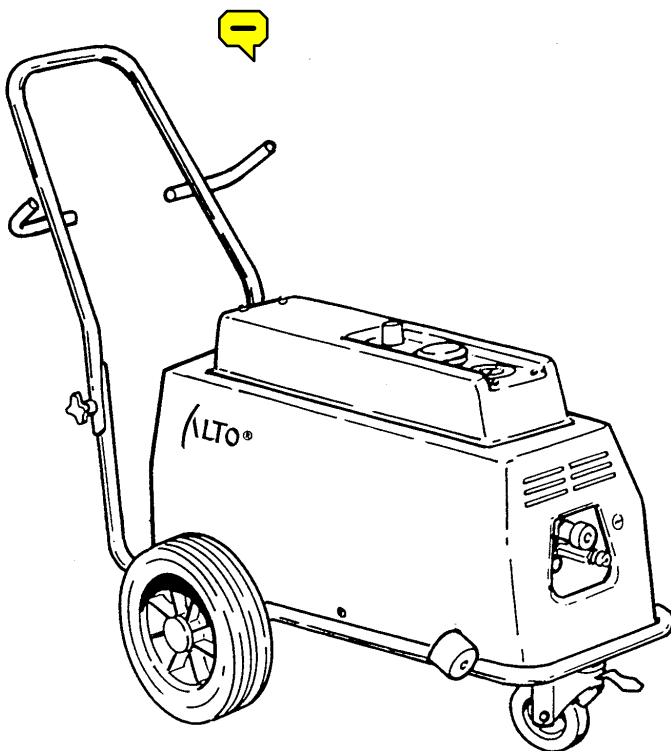

**ALTO**<sup>®</sup>  
Total Cleaning  
Confidence<sup>™</sup>

Reserve de le  
Spare parts  
Ersatzteile  
Pièces détachées

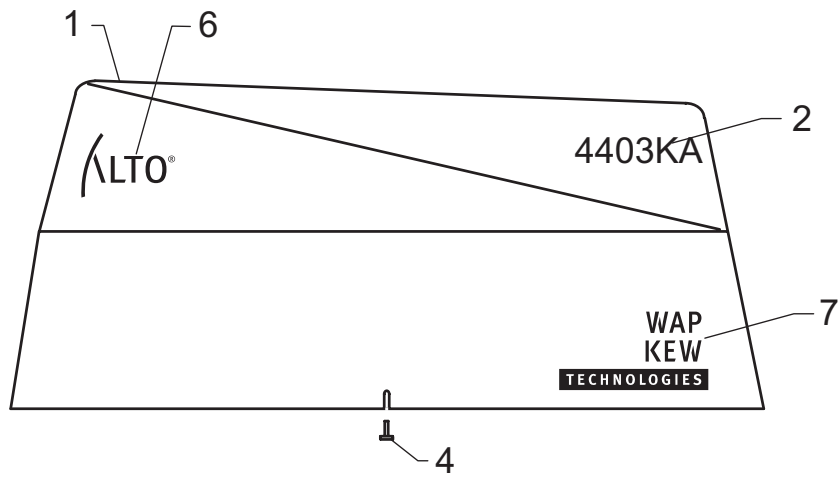
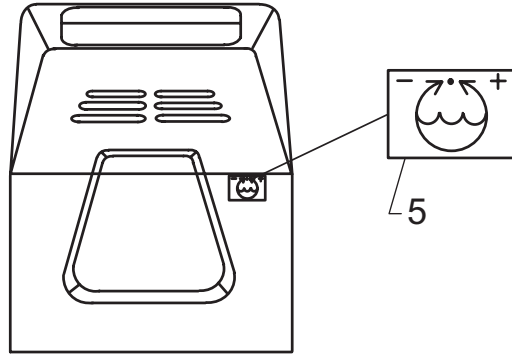
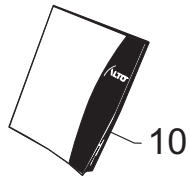

Pos. Ref.	Nr. No.	Betegnelse Bezeichnung	Designation Désignation						
				1903K	2903K	4403K/C3KA	5203K/C3KA	4003K/C3KA	3000C
-	-	Kabinet, kompl. Cabinet, compl. Gehäuse, kompl. Capot, compl.		x	x	x	x	x	x
1	6101428	Kabinet, ALTO Cabinet Gehäuse Capot		1	1	1	1	1	1
2	-	Logo, ALTO Logo Logo Logo		2	2	2	2	2	2
-	6100203	4003K				2			
-	6100206	40C3KA				2			
-	6100200	4403K				2			
-	6100202	4403KR				2			
-	6100208	44C3K				2			
-	6100210	44C3KR				2			
-	6100204	4403KA				2			
-	6100207	4403KRA				2			
-	6100209	44C3KA				2			
-	6100212	44C3KRA				2			
-	6100201	5203K						2	
-	6100211	52C3K						2	
-	6100205	52C3KA						2	
4	1803592	Skrue Screw Schraube Vis		2	2	2	2	2	2
4	1804228	Skrue, RF Screw, SS Schraube, RF Vis, INOX		2	2	2	2	2	2
5	6100184	Symbol f. vandmængdereg. Label, water capacity reg. Aufkleber, Wassermengen. Autocallant, réglage débit		1	1	1	1	1	1
6	6155913	ALTO logo ALTO logo ALTO logo ALTO logo				2	2	2	
7	6155914	KEW TECHNOLOGY logo KEW TECHNOLOGY logo KEW TECHNOLOGY logo KEW TECHNOLOGY logo				2	2	2	
7	6100217	Wap KEW TECHNOLOGIES logo Wap KEW TECHNOLOGIES logo Wap KEW TECHNOLOGIES logo Wap KEW TECHNOLOGIES logo				2	2	2	
8	6100216	Wap ALTO GROUP logo Wap ALTO GROUP logo Wap ALTO GROUP logo Wap ALTO GROUP logo				2	2	2	
9	6124578	Advarselslabel Warning label Warnaufkleber Autocollant d'avertissement		1	1	1	1	1	1
-	4200457	Advarselsskilt Warning sticker Warnaufkleber Plage de bord	f. SF						

Pos. Ref.	Nr. No.	Betegnelse Bezeichnung	Designation Désignation						
				1903K	2903K	4403K/C3KA	5203K/C3KA	4003K/C3KA	3000C
10	-	Instruktionsbog Instructionmanual Betriebsanleitung Livret d'instructions	Wap KEW TECHNOLOGIES						
-	6109218	DK, N, S, SF	03K	x	x	x	x	x	
-	6109219	GB,D,F,NL,E,P,I,GR	03K	x	x	x	x	x	
-	6109400	DK, N, S, SF	C3KA			x	x	x	
-	6109401	GB,D,F,NL,E,P,I,GR	C3KA			x	x	x	
-	6109410	USA	03K,C3KA, 3000C	x	x	x	x	x	x
10	-	Instruktionsbog Instructionmanual Betriebsanleitung Livret d'instructions	Wap ALTO GROUP						
-	6109402	GB,D,F,NL,E,P,I,GR	C3KA			x	x	x	
-	7189014	Tillæg / appendix / Anhang / Annexe				x	x	x	

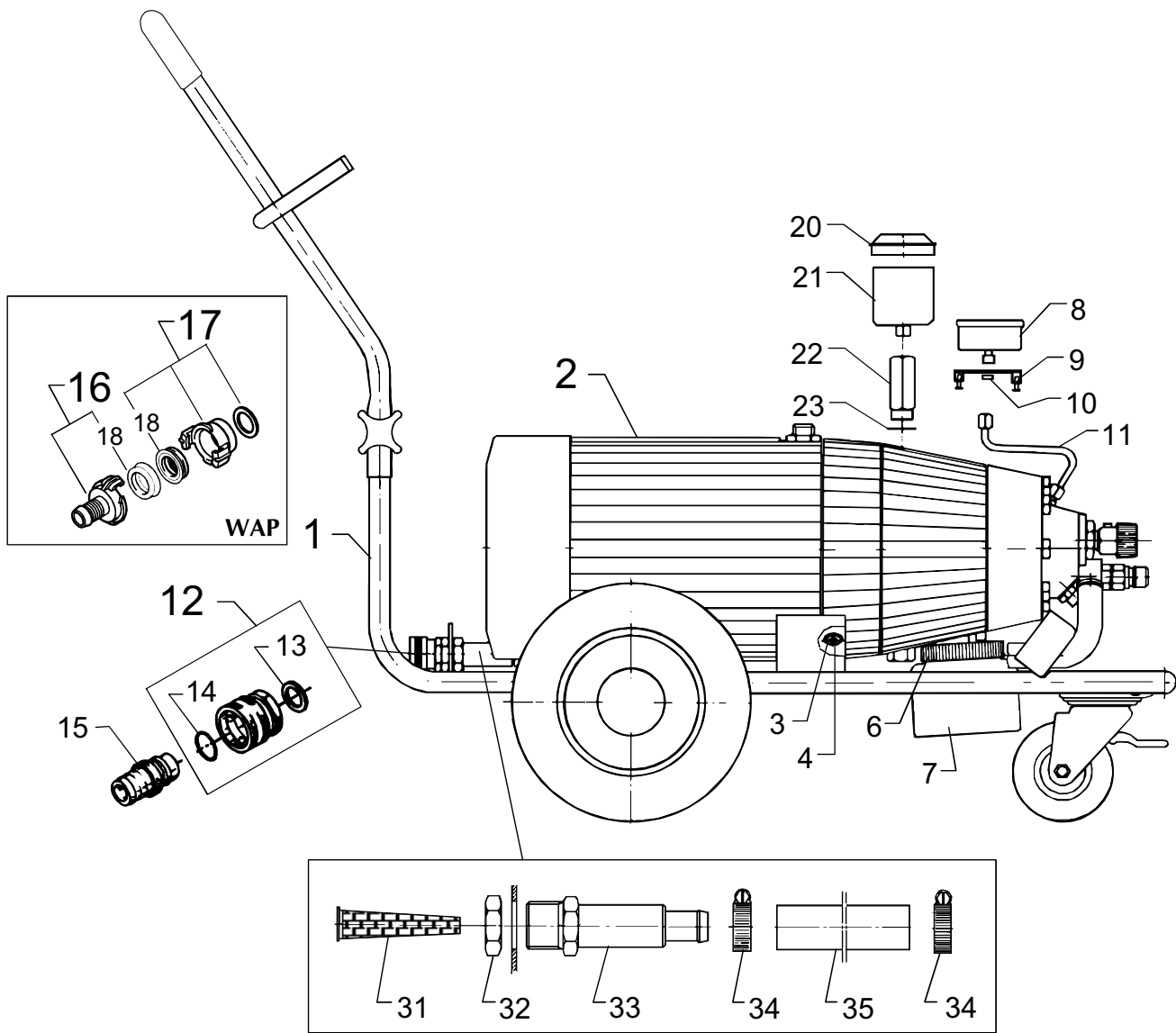

Pos. Ref.	Nr. No.	Betegnelse Bezeichnung	Designation Désignation						
				1903K	2903K	4403K/C3KA	5203K/C3KA	4003K/C3KA	3000C
-	-	Motorp.enhed mont. i stel Motor/pump unit mont. in chas.x Motorp.körper mont. in R. Unité de moteur/pompe		x	x	x	x	x	
1	-	Motorpumpeenhed, komp. Motor/pump unit, compl. Motorpumpenkörper Corps de moteur/pompe		Se side 10 See page 10 SieheSeite 10 Voir page 10					
2	-	Stel, kompl. Chassis, compl. Rahmen, kompl. Châssis, compl.		Se side 8 See page 8 SieheSeite 8 Voir page 8					
3	1801968	Stjerneskive Washer Scheibe Rondelle	M10	4	4	4	4	4	4
4	1802651	Taptite skrue Taptite screw Taptite-Schraube VisTaptite		4	4	4	4	4	4
6	6101625	Slamglaslåg Cover f. sludge container Deckel f. Schlammglas Couvercle, resv. d'huile use		1	1	1	1	1	1
7	2200467	Slamglas Sludge container Schlammglas Reservoir d'huile usée		1	1	1	1	1	1
8	3601262	Manometer Pressure gauge Manometer Manomètre		1	1	1	1	1	1
9	1602127	Manometerring Ring for pressure gauge Manometerring Anneau de manomètre		1	1	1	1	1	1
10	1808088	Spændestykke f. manometer Clamp f. pressure gauge Spannstück f. Manometer Pièce de serrage		1	1	1	1	1	1
11	6220678	Manometertilslutning Manometer connection Manometeranschluß Raccord p. manomètre		1	1	1	1	1	1
12	1602945	Lynkobling, kompl. Quick coupling, compl. Schnellkupplung, Kompl. Coupleur rapide, compl.		x	x	x	x	x	x
13	3001237	Pakning Gasket Dichtung Joint		1	1	1	1	1	1
14	3000320	O-ring O-ring O-Ring Joint torique		1	1	1	1	1	1
15	1600659	Lynkoblingsnippel, 3/4" Quick coupling nipple, 13/4" Schnellkupplungsnippel, 3/4" Coupleur rapide mâle, 3/4"		1	1	1	1	1	1
-	1602473	Lynkoblingsnippel, 5/8" Quick coupl. nipple, 5/8" CH Schnellkupplungsnippel, 5/8" Coupleur rapide mâle, 5/8"		1	1	1	1	1	1
-	1605955	Lynkoblingsnippel Quick coupl. nipple USA Schnellkupplungsnippel Coupleur rapide mâle	USA	1	1	1	1	1	1
16	1311	Geka koblingsnippel 3/4" Geka-coupling nipple 3/4" WAP Geka-Schlauchtülle 3/4" Coupleur mâle Geka 3/4"				1	1	1	
17	1718	Geka kopling 3/4" Geka-threaded piece 3/4" WAP Geka-Gewindestück 3/4" Coupleur Geka 3/4"				1	1	1	
18	6502	Pakning for Geka kobling Packing for Geka coupling WAP Dichtung für Geka-Kupplung Joint pour coupleur Geka				2	2	2	

Pos. Ref.	Nr. No.	Betegnelse Bezeichnung	Designation Désignation						
				1903K	2903K	4403K/C3KA	5203K/C3KA	4003K/C3KA	3000C
20	2201854	Låg Cover Deckel Couvercle		1	1	1	1	1	1
21	2200285	Olieglas Oil container Ölbehälter Reservoir d'huile		1	1	1	1	1	1
22	2200293	Studs Socket Stutzen Raccord		1	1	1	1	1	1
23	3000361	Kobberskive Copper washer Kupferscheibe Rondelle en cuivre		1	1	1	1	1	1
30	-	Vandtilgang, kompl. Water, inlet, compl. Einlaß f. Wasser, Kompl. Tube d'admission, compl.		x	x	x	x	x	x
31	6100941	Filter Filter Filter Filtre		1	1	1	1	1	1
32	1800341	Kontramøtrik Lock nut Gegenmutter Contre écrou		1	1	1	1	1	1
33	6100937	Filterhus Housing f. filter Filtergehäuse Gainé de filtre d'eau		1	1	1	1	1	1
33	6101094	Filterhus, messing Housing f. filter, brass Filtergehäuse, Messing Gainé de filtre d'eau, laiton		1	1	1	1	1	1
34	1802107	Spændebånd Hose clip Schlauchschelle Collier de serrage		2	2	2	2	2	2
35	6101405	Slange Hose Schlauch Tuyau		1	1	1	1	1	1

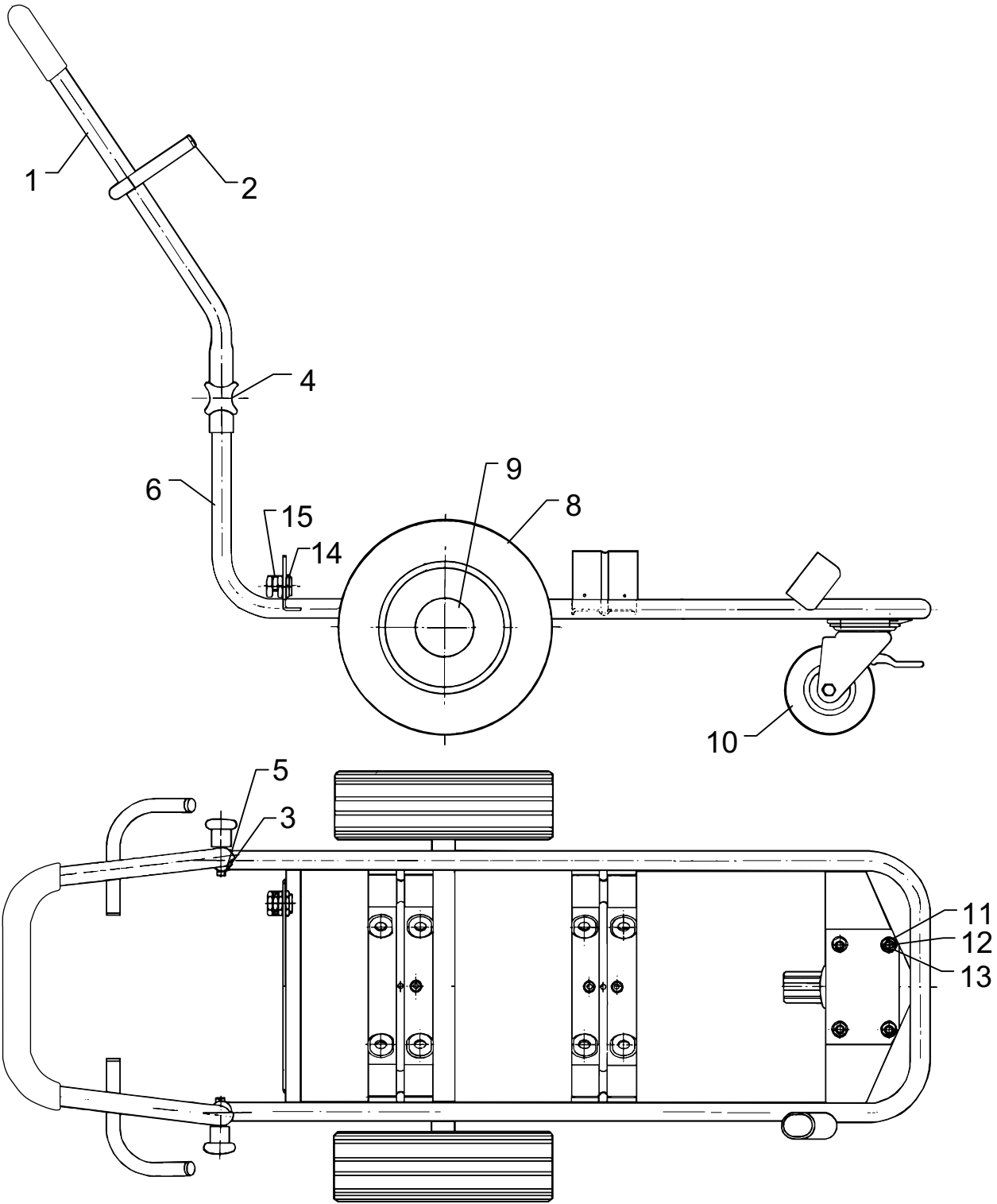

Pos. Ref.	Nr. No.	Betegnelse Bezeichnung	Designation Désignation	1903K	2903K	4403K/C3KA	5203K/C3KA	4003K/C3KA	3000C
-	-	Stel, kompl. Chassis, compl. Rahmen, kompl. Châssis, compl.		x	x	x	x	x	x
1	6101600	Bagbøjle Clamp rear Bügel, Hinten Collier, arrière,		1	1	1	1	1	1
1	6102611	Bagbøjle, RF Clamp rear, SS Bügel, Hinten, RF Collier, arrière, INOX	03KR	1	1	1	1	1	1
2	4600664	Dupsko Ferrule Zwinge Fer		4	4	4	4	4	4
3	6100123	Skrue Screw Schraube Vis		2	2	2	2	2	2
3	1804178	Skrue, RF Screw, SS Schraube, RF Vis, INOX	03KR	2	2	2	2	2	2
4	4000279	Stjernerieb Starhandle Sterngriff Bouton		2	2	2	2	2	2
5	4600559	Dupsko Ferrule Zwinge Fer		2	2	2	2	2	2
6	6101689	Stel Chassis Rahmen Chassis		1	1	1	1	1	1
6	6102612	Stel, RF Chassis, SS Rahmen, RF Chassis, INOX	03KR	1	1	1	1	1	1
6	6100179	Stel Chassis Rahmen Chassis	f. CDN, J	1	1	1	1	1	1
8	2004257 301000041	Kørehjul Wheel Rad Roue	⇒ 24.04.01     25.04.01 ⇒	2	2	2	2	2	2
8	2010908	Kørehjul Wheel Rad Roue	03KR	2	2	2	2	2	2
9	6102614	Navkapsel RF, kompl. Hub cap SS, compl. Nabenkappe RF, kompl. Chapeau de roue INOX, compl.		2	2	2	2	2	2
9	2004265	Navkapsel, kompl. Hub cap, compl. Nabenkappe, kompl. Chapeau de roue, compl.		2	2	2	2	2	2
10	2012144	Drejehjul Steerable wheel Lenkrolle Roue pivotante		1	1	1	1	1	1
10	2010916	Drejehjul Steerable wheel Lenkrolle Roue pivotante	03KR	1	1	1	1	1	1
11	1803725	Møtrik Nut Mutter Écrou	M 8	4	4	4	4	4	4
11	1801905	Møtrik, RF Nut, SS Mutter, RF Écrou, INOX	03KR	4	4	4	4	4	4
12	1800820	Sætskrue Set screw Gewinde stift Vis de blocage	M8x20	4	4	4	4	4	4

Pos. Ref.	Nr. No.	Betegnelse Bezeichnung	Designation Désignation	1903K	2903K	4403K/C3KA	5203K/C3KA	4003K/C3KA	3000C
12	1802909	Sætskrue, RF Set screw, SS Gewindestift, RF Vis de blocage, INOX	03KR	4	4	4	4	4	4
13	1801398	Skive Washer Scheibe Rondelle	M8	4	4	4	4	4	4
13	1802917	Skive, RF Washer, SS Scheibe, RF Rondelle, INOX	03KR	4	4	4	4	4	4
14	3800786	Låsemøtrik Lock nut Gegenmutter Écrou de blocage	M8	1	1	1	1	1	1
14	3808169	Låsemøtrik Lock nut Gegenmutter Écrou de blocage	f. CDN, J	1	1	1	1	1	1
15	3800760	Kabelafastning Cable lead-in Zugentlastung Passe fil		1	1	1	1	1	1
15	3802212	Kabelafastning Cable lead-in Zugentlastung Passe fil	f. CDN, J	1	1	1	1	1	1

598 64 99 - 020302

A	6109046
A <sub>1</sub>	1119570
A <sub>2</sub>	1119568
B	1119035
B <sub>1</sub>	1119571
C	1119820
D	1119310
D	1119195
E	1118538
F	1118520
F	1118580
F	1119315
G	1118512

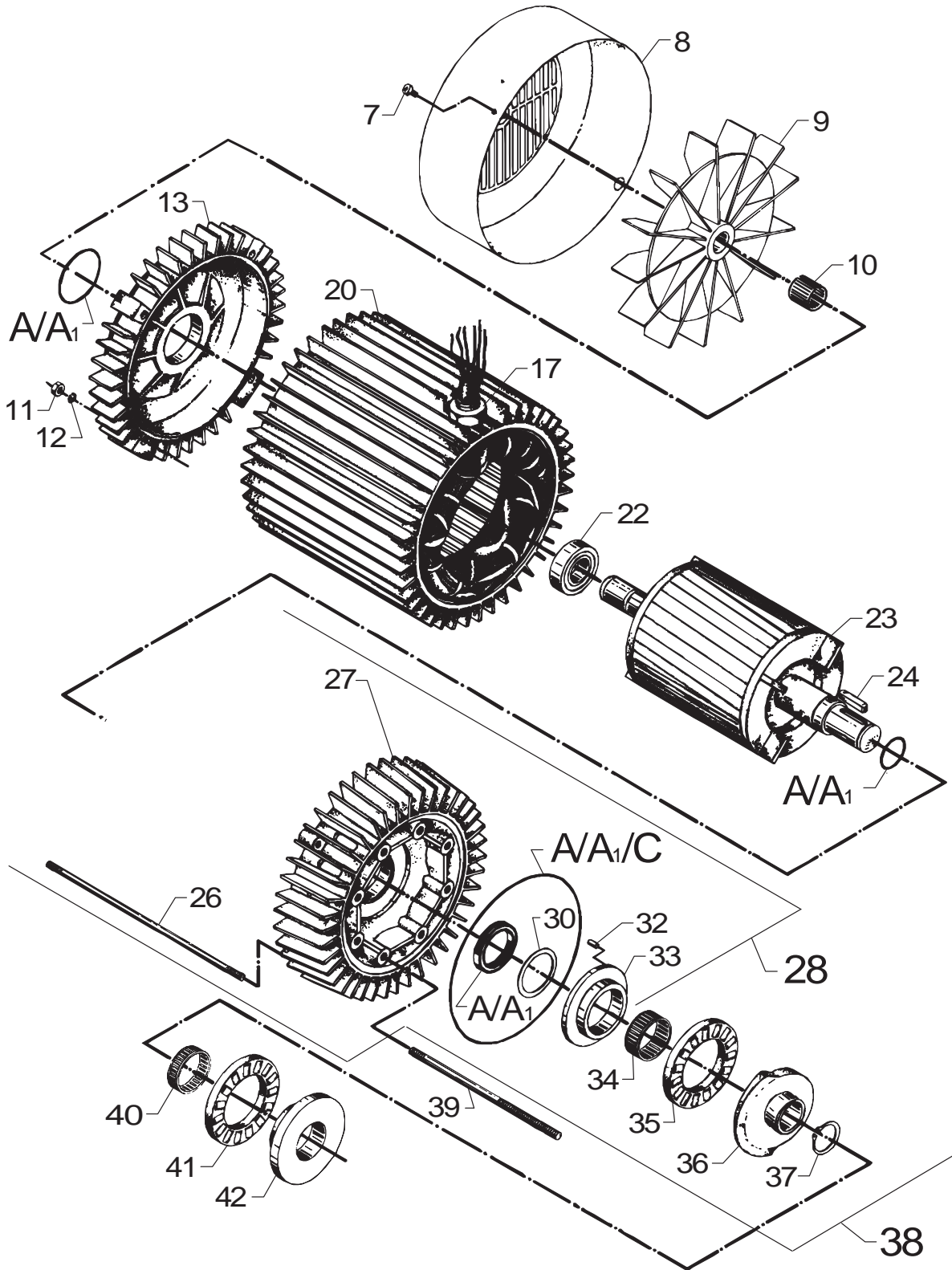



Pos. Ref.	Nr. No.	Betegnelse Bezeichnung	Designation Désignation	1903K	2903K	4403K/C3KA	5203K/C3KA	4003K/C3KA	3000C
-	-	<b>Motorpumpeenhed, komp. Motor/pump unit, compl. Motorpumpenkörper, Corps de moteur/pompe</b>		x	x	x	x	x	x
7	1802586	Skrue Screw Schraube Vis		2	2	2	2	2	2
8	6100609	Ventilatorskærm Fan guard Ventilatorschutzblech Capot ventilateur		1	1	1	1	1	1
9	6100605	Ventilator Fan Ventilator Ventilateur		1	1	1	1	1	1
10	1802503	Låsering Circlip Schließring Circlip		1	1	1	1	1	1
11	1803725	Møtrik Nut Mutter Ecrou		4	4	4	4	4	4
12	1801182	Fjederskive Spring washer Federscheibe Rondelle ressort		4	4	4	4	4	4
13	6100611	N-lejedæksel Rear bearing cover N-Lagerdeckel AR-flasque de carter		1	1	1	1	1	1
17	6101414	Bøsning Bush Buchse Baque		1	1	1	1	1	1
<b>20</b>	-	<b>Stator med statorhus Stator with stator housing Stator mit Statorgehäuse Stator a. enveloppe de stat.</b>							
-	6100810	2.4kW, 50Hz, 1x110V		1					
-	6100814	3.7kW, 50Hz, 3x415V			1				
-	6100815	3.7kW, 50Hz, 3x220/380V			1				
-	6100819	3.7kW, 50Hz, 3x200/340V			1				
-	6100835	3.7kW, 60Hz, 1x208/230V			1				
-	6100823	5.5kW, 50Hz, 3x380/660V				1			
-	6100824	5.5kW, 50Hz, 3x415V				1			
-	6100825	5.5kW, 50Hz, 3x220/380V				1			
-	6100829	5.5 kW, 50Hz, 3 x 200-340 V				1			
-	6100840	6.5kW, 50Hz, 3x415V					1		
-	6100841	6.5kW, 50Hz, 3x220/380V					1		1
-	6100845	6.5kW, 50Hz, 3x200/340V						1	
-	6100847	6.5kW, 50Hz, 3x500V						1	
-	6100850	5.5kW, 50Hz, 1x208/230V							1
22	3200623	N-leje Rear bearing N-Lager AR-roulement		1	1	1	1	1	1
<b>23</b>	-	<b>Aksel m. rotor Shaft w. rotor Welle m. Rotor Rotor</b>							
-	6101002	Shaft w. 130mm rotor, 3.7kW		1					
-	6100997	Shaft w. 130mm rotor, 3.7 kW			1				
-	6100998	Shaft w. 145mm rotor, 5.5 kW				1			
-	6100999	Shaft w. 155mm rotor, 3.7kW		1					
-	6101000	Shaft w. 170mm rotor, 6.5kW					1		1
-	6101001	Shaft w. 190mm rotor, 5.0kW						1	1
24	3200672	Feder Key Federkeil Clavette		1	1	1	1	1	1
26	6100711	Stagbolt L=261mm Stud Stehbolzen Entretoise		4	4	4			4

Pos. Ref.	Nr. No.	Betegnelse Bezeichnung	Designation Désignation	1903K	2903K	4403K/C3KA	5203K/C3KA	4003K/C3KA	3000C
26	6100712	Stagbolt L=306mm Stud Stehbolzen Entretoise						4	4
27	6101749	D-lejedæksel Front bearing cover D-Lagerdeckel AV-flasque de carter		1	1	1	1	1	1
<b>28</b>	<b>6101750</b>	<b>D-lejedæksel, komplet Front bearing cover, compl. D-Lagerdeckel, komplett AV-flasque de carter, compl.</b>		x	x	x	x	x	x
30	6100995	Skive Washer Scheibe Rondelle		1	1	1	1	1	1
32	6100996	Styrestift Guide pin Kegelstift Goupille		1	1	1	1	1	1
33	107120703	Lejeskive tynd Bearing track thin Lagerscheibe Dünn Rondelle de palier mince		1	1	1	1	1	1
34	3200656	Nåleleje Needle bearing Nadellager Roulement à aiguille		1	1	1	1	1	1
35	3200615	Rulleleje Roller bearing Rollenlager Roulement		1	1	1	1	1	1
36	-	Skråskive Wobble disc Taumelscheibe Disque oblique							
-	107120705	<b>1</b>	2.4kW, 50/60 Hz	1					
-	107120707	<b>3</b>	3.7kW, 60 Hz		1				1
-	107120708	<b>4</b>	5.0kW, 60 Hz					1	
-	107120708	<b>4</b>	5.5kW, 60 Hz			1			
-	107120710	<b>6</b>	3.7kW, 50 Hz		1				
-	107120710	<b>6</b>	6.5kW, 60 Hz				1		
-	107120715	<b>11</b>	5.5kW, 50 Hz			1			
-	107120716	<b>12</b>	6.5kW, 50 Hz				1		
37	1802511	Seegerring Seeger circlip ring Seeger-Ring Anneau Seeger							<b>Se side 16 See page 16 SieheSeite 16 Voir page 16</b>
<b>38</b>	-	<b>Motor, komplet Motor, complete Motor, komplett Moteur, compl.</b>							
39	6100710	Stagbolt Stud Stehbolzen Entretoise		8	8	8	8	8	8
39	6301368	Stagbolt Stud Stehbolzen Entretoise	<b>C3</b>			8	8	8	8
40	3200664	Nåleleje Needle bearing Nadellager Roulement à aiguille		1	1	1	1	1	1
41	3200615	Aksialrulleleje Axial roller bearing Axialrollenlager Roulement		1	1	1	1	1	1
42	107120704	Lejeskive Bearing track Lagerscheibe Plaque de palier		1	1	1	1	1	1
<b>A</b>	<b>6109046</b>	<b>Rep.sæt, pakninger Rep.kit, gaskets Rep.satz, Dichtungen Kit de joints</b>	<b>03K</b>	x	x	x	x	x	
<b>A<sub>1</sub></b>	<b>1119570</b>	<b>Rep.sæt, pakninger Rep.kit, gaskets Rep.satz, Dichtungen Kit de joints</b>	<b>C3</b>			x	x	x	x

A	6109046
A <sub>1</sub>	1119570
A <sub>2</sub>	1119568
B	1119035
B <sub>1</sub>	1119571
C	1119820
D	1119310
D	1119195
E	1118538
F	1118520
F	1118580
F	1119315
G	1118512

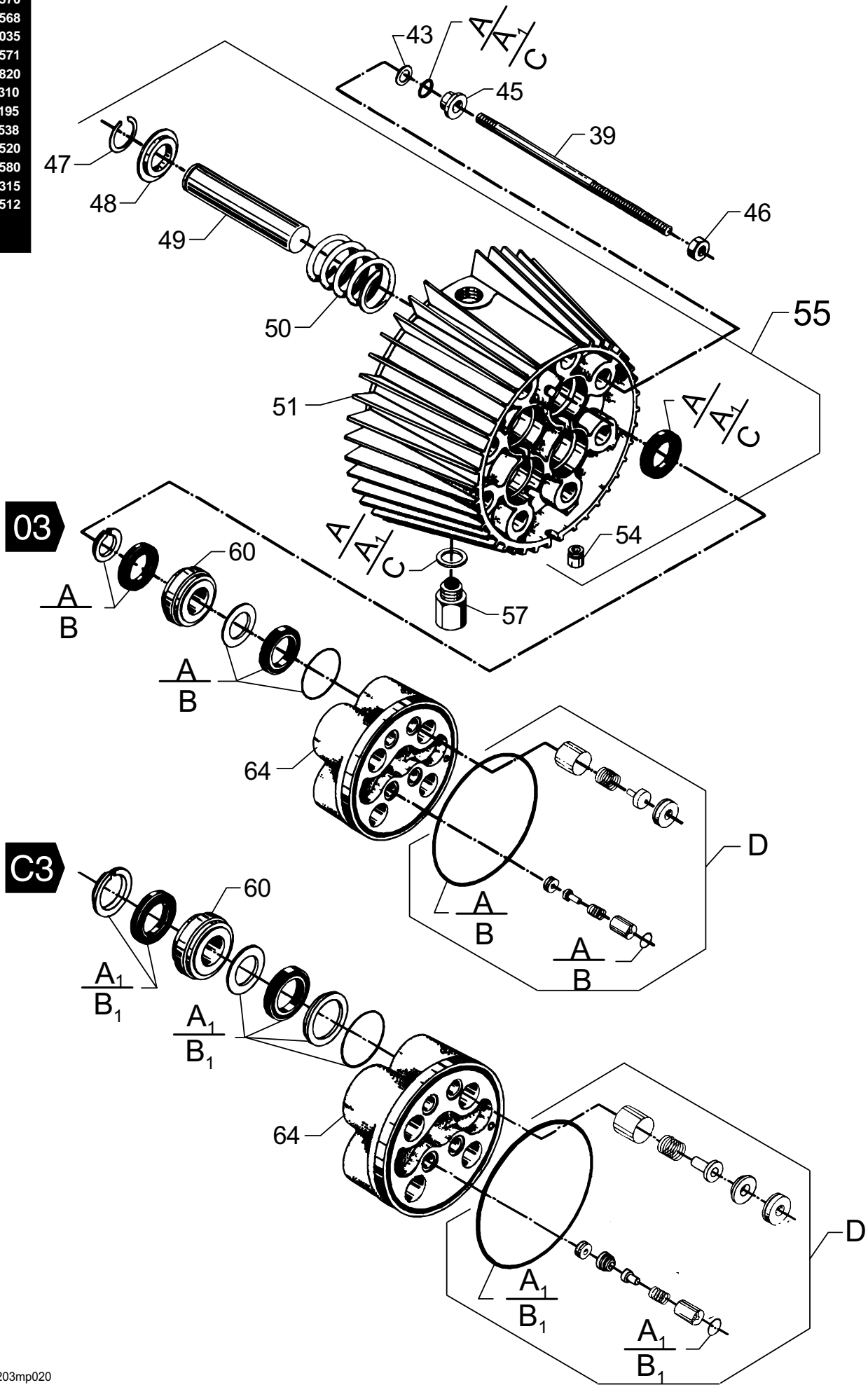

203mp020

598 64 99 - 020302

Pos. Ref.	Nr. No.	Betegnelse Bezeichnung	Designation Désignation	1903K	2903K	4403K/C3KA	5203K/C3KA	4003K/C3KA	3000C
43	6100718	Skive Washer Scheibe Rondelle		8	8	8	8	8	8
45	6100719	Trykring Thrust collar Druckring Anneau d'arrêt		8	8	8	8	8	8
46	1800465	Møtrik M10 Nut Mutter Ecrou		8	8	8	8	8	8
47	1802529	Låsering Circlip Schließring Anneau		4	4	4	4	4	4
48	6100666	Ring til returfjeder Ring for return spring Ring für Rückzugfeder Anneau p. ressort de rap.		4	4	4	4	4	4
49	6100901	Stempel Piston Druckkolben Piston		4	4	4	4	4	
49	6301166	Keramisk stempel Piston ceramic Keramischer Druckkolben Piston ceramique	C3			4	4	4	4
50	2602274	Returfjeder Return spring Rückzugfeder Ressort de rappel		4	4	4	4	4	
50	102602517	Returfjeder Return spring Rückzugfeder Ressort de rappel	C3			4	4	4	4
51	6100610	Cylinderblok Cylinder block Zylinderblock Carter-cylindre		1	1	1	1	1	1
54	6100919	Dryptud Drip nozzle Tropfendüse Tuyau d'égouttage		1	1	1	1	1	1
55	6101702	Cylinderblok, komplet Cylinder block, complete Zylinderblock, komplett Carter-cylindre, compl.		x	x	x	x	x	
55	6300071	Cylinderblok, komplet Cylinder block, compl. Zylinderblock, komplett Carter-cylindre, compl.	C3			x	x	x	x
57	6150400	Bundprop Drain plug Verschlußpropfen Bouchon de vidange		1	1	1	1	1	1
60	6100631	Trykring Thrust collar Druckring Anneau d'arrêt		4	4	4	4	4	
60	6301313	Trykring Thrust collar Druckring Anneau d'arrêt	C3			4	4	4	4
64	6100907	Topstykke Cylinder head Zylinderkopf Culasse		1	1	1	1	1	
64	6301335	Topstykke Cylinder head Zylinderkopf Culasse	C3			1	1	1	1

Pos. Ref.	Nr. No.	Betegnelse Bezeichnung	Designation Désignation	1903K	2903K	4403K/C3KA	5203K/C3KA	4003K/C3KA	3000C
B	1119035	Rep.sæt, pakninger (red.) Rep.kit, gaskets (reduced) Rep.satz, Dichtungen (red.) Kit de joints (réduit)	03K	x	x	x	x	x	
B <sub>1</sub>	1119571	Rep.sæt, pakninger (red.) Rep.kit, gaskets (red.) Rep.satz, Dichtungen (red.) Kit de joints (réduit)	C3			x	x	x	x
C	1119820	Rep.sæt, olietætning Rep.kit, oil seal Rep.satz, Öldichtung Kit de joint étanche à l'huile		x	x	x	x	x	x
D	1119310	Rep.sæt, ventilsystem Rep.kit, valve system Rep.satz, Ventilsystem Kit, système de soupape	03	x	x	x	x	x	
D <sub>1</sub>	1119195	Rep.sæt, ventilsystem Rep.kit, valve system Rep.satz, Ventilsystem Kit, système de soupape	C3			x	x	x	x
D <sub>2</sub>	6300080	Ventil, komplet - sug Valve, compl. - suction Ventil, komplett - Ansaug Soupape, compl. - asp.	C3			4	4	4	4
D <sub>3</sub>	6300079	Ventil, komplet - tryk Valve, compl. -pressure Ventil, komplett - Druck Soupape, compl. -pression	C3			4	4	4	4

- A 6109046
- A<sub>1</sub> 1119570
- A<sub>2</sub> 1119568
- B 1119035
- B<sub>1</sub> 1119571
- C 1119820
- D 1119310
- D 1119195
- E 1118538
- F 1118520
- F 1118580
- F 1119315
- G 1118512

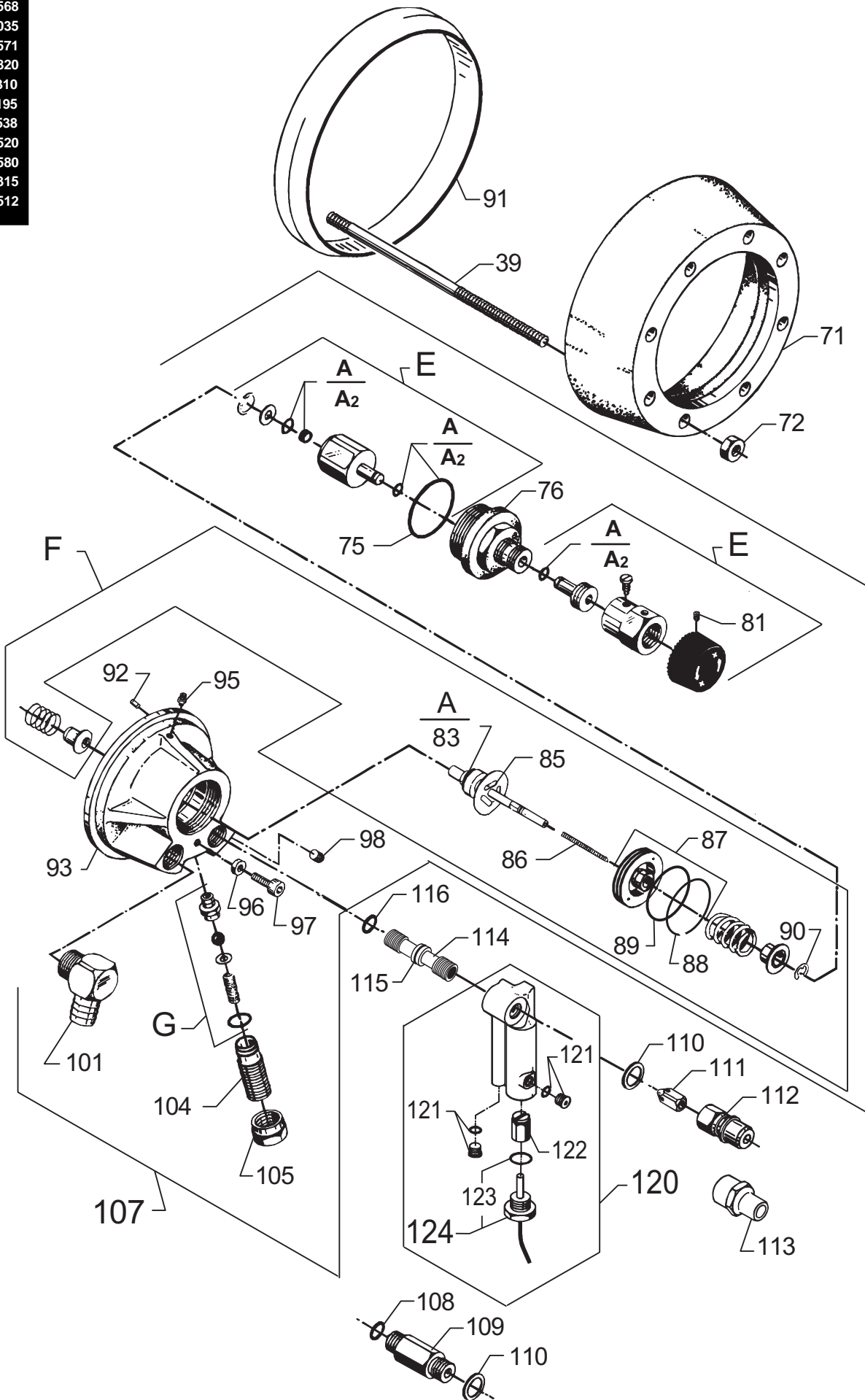

203mp030

598 64 99 - 020302

Pos. Ref.	Nr. No.	Betegnelse Bezeichnung	Designation Désignation	1903K	2903K	4403K/C3KA	5203K/C3KA	4003K/C3KA	3000C
71	6100602	Spændering Retaining ring Spanning Flaque AV pompe		1	1	1	1	1	1
72	1800465	Møtrik M10 Nut Mutter Ecrou		8	8	8	8	8	8
75	3001179	O-ring O-ring O-Ring Joint torique		1	1	1	1	1	1
76	6100984	Bøsning Bushing Buchse Manchon		1	1	1	1	1	1
81	1802602	Kraterskrue Crater-point screw Kraterschraube Vis		1	1	1	1	1	1
83	3000460	O-ring O-ring O-Ring Joint torique		1	1	1	1	1	1
<b>85</b> -	<b>6101784</b> <b>6400143</b>	<b>Ventilkegle, komplet</b> <b>Valve cone, complete</b> <b>Ventil kegel, komplett</b> <b>Cône p. clapet, compl.</b>	<b>K</b> <b>KA</b>	1	1	1	1	1	1
86	2600286	Fjeder Spring Feder Ressort		1	1	1	1	1	1
87	6100925	Stempel, kompl. Piston, compl. Kolben, komplett Piston, compl.		1	1	1	1	1	
87	6228554	Stempel, kompl. Piston, compl. Kolben, komplett Piston, compl.	<b>3000C</b>						1
88	6101061	Stempelring Piston ring Kolbenring Anneau piston		1	1	1	1	1	1
89	3001716	O-ring O-ring O-Ring Joint torique		1	1	1	1	1	1
90	6101069	Seegerring Seeger circlip ring Seeger-Ring Anneau Seeger		1	1	1	1	1	1
91	6301392	Ring Ring ø 160 Ring Anneau	<b>C3</b>			1	1	1	1
92	6100996	Styrestift Guide pin Kegelstift Goupille		1	1	1	1	1	1
93	6101042	Ventildæksel Valve cover Ventildeckel Corp by-pass		1	1	1	1	1	1
95	1603422	Ligeforskrøning Threaded connection Verschraubung Raccord fileté		1	1	1	1	1	1
96	6100985	Låseskive Lock washer Haltescheibe Disque de blocage		1	1	1	1	1	1
97	1802636	Skrue Screw Schraube Vis		1	1	1	1	1	1
98	1602333	Rørprop Pipe plug Rohrschlußstück Bouchon de tuyau		2	2	2	2	2	2

Pos. Ref.	Nr. No.	Betegnelse Bezeichnung	Designation Désignation	1903K	2903K	4403K/C3KA	5203K/C3KA	4003K/C3KA	3000C
101	6101752	Slangestuds, vinkel Hose socket, elbow Schlauchstutzen, Winkel Raccord de flexible, coude		1	1	1	1	1	1
104	6100940	Justerskrue Adjustment screw Justierschraube Vis de réglage		1	1	1	1	1	1
105	6100928	Kontramøtrik Lock nut Gegenmutter Ecrou contre		1	1	1	1	1	1
<b>107</b>	<b>6101753</b>	<b>Omløbsventil, komplet</b> <b>By-pass valve, compl.</b> <b>Umlaufventil, komplett</b> <b>Soupape by-pass, compl.</b>		x	x	x	x	x	
-	<b>6104740</b>	<b>Omløbsventil, komplet</b> <b>By-pass valve, compl.</b> <b>Umlaufventil, komplett</b> <b>Soupape by-pass, compl.</b>							x
108	3000064	O-ring O-ring O-Ring Joint torique		1	1	1	1	1	1
109	6101018	Studs f. lynkobling Socket f. quick coupling Stutzen f. Schnellkupplung Raccord rapide		1	1	1	1	1	1
110	1801075	Tætningsskive Sealing washer Anschleißscheibe Rondelle		1	1	1	1	1	1
111	6101038	Stempel-kontraventil Piston-non return valve Kolben-rückschlagventil	<b>K</b>	1	1	1	1	1	1
-	6101083	Piston clapet anti-retour	<b>KA</b>			1	1	1	
112	1600493	Lynkoblingsnippel Quick coupling nipple Schnellkupplungsnippel Raccord rapide mâle		1	1	1	1	1	1
112	1603101	Lynkoblingsnippel, RF Quick coupling nipple, SS Schnellkupplungsnippel,RF Raccord rapide mâle, INOX		1	1	1	1	1	1
113	1609335	Konverter (højtryk) Converter (high pressure) <b>WAP</b> Konverter (Hochdruck) Convertisseur (haute pression)				1	1	1	
114	6400712	Bøsning Bush Busche Baque	<b>KA</b>			1	1	1	
115	3001682	O-ring O-ring O-Ring Joint torique	<b>KA</b>			1	1	1	
116	3001252	O-ring O-ring O-Ring Joint torique	<b>KA</b>			1	1	1	
<b>A<sub>2</sub></b>	<b>1119568</b>	<b>Rep.sæt, pakninger f. omløb.</b> <b>Kit, gaskets f. by-pass v. C3</b> <b>Rep.satz, Dichtungen f. Uml.</b> <b>Kit joints p. soupape by-pass</b>				x	x	x	x
<b>E</b>	<b>1118538</b>	<b>Rep.sæt, greb f. omløbsven.</b> <b>Kit, adj. mechanism, by-pass</b> <b>Rep.satz, Justiereinrichtung</b> <b>Kit, bouton de soupape by-p.</b>		x	x	x	x	x	x
<b>F</b>	<b>1118520</b>	<b>Rep.sæt, omløbsventil</b> <b>Rep.kit, by-pass valve</b> <b>Rep.satz, Umlaufventil</b>	<b>K</b>	x	x	x	x	x	
-	<b>1118580</b>	<b>Kit, soupape by-pass</b>	<b>KA</b>			x	x	x	
<b>F</b>	<b>1119315</b>	<b>Rep.sæt, omløbsventil</b> <b>Rep.kit, by-pass valve</b> <b>Rep.satz, Umlaufventil</b> <b>Kit, soupape by-pass</b>	<b>3000C</b>						x
<b>G</b>	<b>1118512</b>	<b>Rep.sæt, sikkerhedsventil</b> <b>Rep.kit, safety valve</b> <b>Rep.satz, Überdruckventil</b> <b>Kit, soupape de sûreté</b>		x	x	x	x	x	x

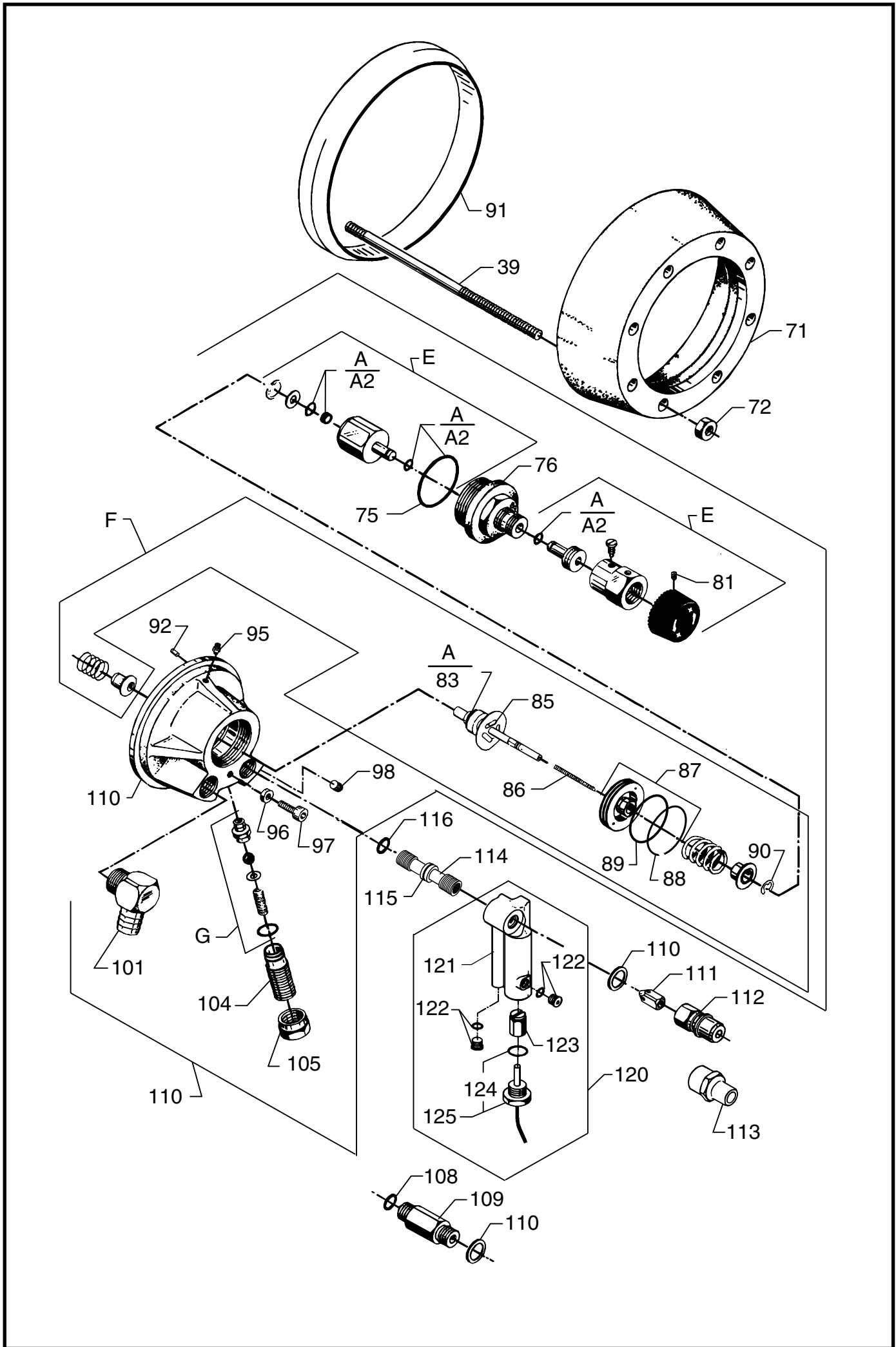

Pos. Ref.	Nr. No.	Betegnelse Bezeichnung	Designation Désignation								
				1903K	2903K	4403K/C3KA	5203K/C3KA	4003K/C3KA	3000C		
120	6403461	<b>Stråmningskontakt</b> <b>Flow switch</b> <b>Strömungsschalter</b> <b>Circulation sélecteur</b>	<b>C3KA</b>			x	x	x			
121	6401825	Hus Housing Gehäuse Carter			1	1	1				
122	6180913	Blændprop m. O-ring Plug with O-ring Pfropfen mit O-Ring Bouchon avec joint torique			2	2	2				
123	6350454	Stempel, kompl. Piston, compl. Kolben, kompl. Piston, compl.			1	1	1				
124	3000825	O-ring O-ring O-Ring Joint torique			1	1	1				
125	6221773	<b>Reedkontakt m. O-ring</b> <b>Reed switch with O-ring</b> <b>Reedschalter mit O-ring</b> <b>Reed sélecteur avec joint torique</b>			1	1	1				
<b>38</b>	-	<b>Motor, komplet</b> <b>Motor, complete</b> <b>Motor, komplett</b> <b>Moteur, compl.</b>		x	x	x	x	x	x		
-	6101704	2.4kW, 50Hz, 1x110V		1							
-	6101708	3.7kW, 50Hz, 3x380/415V			1						
-	6101709	3.7kW, 50Hz, 220/380V			1						
-	6101710	3.7kW, 60Hz, 3x440V			1						
-	6101712	3.7kW, 60Hz, 3x200/340V			1						
-	6101713	3.7kW, 50Hz, 3x200/340V			1						
-	6101729	3.7kW, 60Hz, 3x208/230V			1						
-	6101718	5.5 kW, 50Hz, 3x380/415V				1					
-	6101719	5.5 kW, 50Hz, 3x220/380V				1					
-	6101720	5.5 kW, 60Hz, 3x220/460V				1					
-	6101722	5.5kW, 60Hz, 3x200/340V				1					
-	6101723	5.5kW, 50Hz. 200/380V				1					
-	6101724	5.5kW, 50Hz, 3x380/660V				1					
-	6101734	6.5kW, 50Hz, 3x380/415V					1				
-	6101735	6.5kW, 50Hz, 3x220/380V					1				
-	6101736	6.5kW, 60Hz, 3x440V					1				
-	6101738	6.5kW, 60Hz, 3x200/340V					1				
-	6101739	6.5kW, 50Hz, 3x200/340V					1				
-	6101740	6.5kW, 50Hz, 3x380/660V					1				
-	6101741	6.5kW, 50Hz, 3x500V					1				
-	6101744	5.0kW, 60Hz, 3x208/230V						1			
-	6104741	6.5kW, 60Hz, 3x460V							1		

Pos. Ref.	Nr. No.	Betegnelse Bezeichnung	Designation Désignation								
				1903K	2903K	4403K/C3KA	5203K/C3KA	4003K/C3KA	3000C		

598 64 99 - 020302

El-dele / Electric parts / Elektrische Teile / Pièces électrique  
**C3KA**

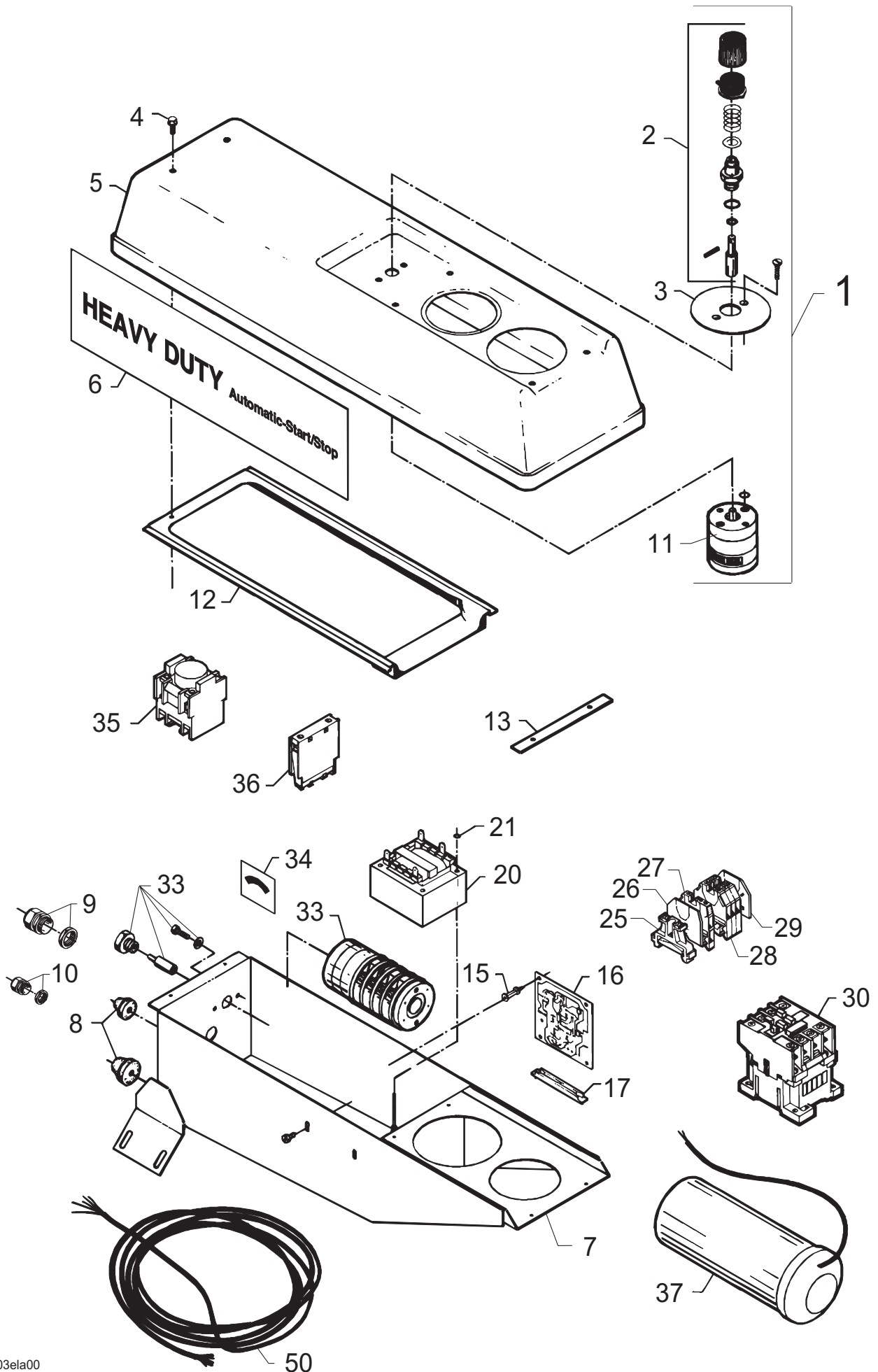

203ela00



Pos. Ref.	Nr. No.	Betegnelse Bezeichnung	Designation Désignation			44C3KA	52C3KA	40C3KA	
-	-	<i>El-dele</i> <i>El. components</i> C3KA <i>Electrische Teile</i> <i>Pièces électrique</i>							
1	3821728	<b>Start/stop kontakt, kompl</b> <b>Start/stop switch, compl.</b> <b>Start/Stop Schalter, kompl.</b> <b>Bouton marche/arrêt, compl.</b>				x	x	x	
2	1117357	<b>Drejekontakt, kompl.</b> <b>Adjusting knob, kompl.</b> <b>Drehschalter, kompl.</b> <b>Interrupteur à rotation</b>				1	1	1	
3	6101010	Skalaplade Dial plate Skalenplatte Echelle				1	1	1	
4	1803956	Taptite skrue Taptite screw M4x12 Taptiteschraube Vis Taptite				6	6	6	
5	6101400	Instrumentkasse, låg Instrument box, cover Instrumentengehäuse, Deckel Boîte à instrumente, couvercle				1	1	1	
5	6104404	Instrumentkasse, låg Instrument box, cover Y/Δ Instrumentengehäuse, Deckel Boîte à instrumente, couvercle				1	1	1	
6	6104403	Label Label Autokleber Autocollant				2	2	2	
7	-	Instrumentkasse Instrument box Instrumentengehäuse Boîte à instrumente							
-	6101656	24.09.99 ⇒				1	1	1	
-	6104616	⇒ 23.09.99				1	1	1	
-	6104617	⇒ 23.09.99	Y/Δ			1	1	1	
8	-	Pakdåse Cable grommet Stopfbuchse Presse-étoupe							
-	3803764	TET 5 - 7C							
-	3803772	TET 7 - 10C							
-	3803780	TET 10 - 14C ⇒ 23.09.99							
-	3803798	TET 14 - 20C ⇒ 23.09.99							
9	3830125	Kabelgennemføring PG 21 Cable gland   24.09.99 ⇒ Kabeldurchführung Traversée				1	1	1	
10	3830124	Kabelgennemføring PG 16 Cable gland   24.09.99 ⇒ Kabeldurchführung Traversée				1	1	1	
11	3821726	Start/stop kontakt Start/stop switch Start/Stop Schalter Bouton marche/arrêt				x	x	x	
12	6100115	Pakning f. instr. kasse Gasket f. instr. box Dichtung f. Instrumentengehäuse Joint p. boîte				1	1	1	
13	6100116	Pakning Gasket Dichtung Joint				1	1	1	
15	4600771	Printstag Plug f. circuit board Stecker f. Print Prise p. circuit imprimé				4	4	4	
16	6420012	Automatisk start/stop Automatic start/stop Start/Stop Automatisk Marché/ arrêt auto.				1	1	1	

Pos. Ref.	Nr. No.	Betegnelse Bezeichnung	Designation Désignation			44C3KA	52C3KA	40C3KA	
17	3821184	Bæreskinne Connection rail Schiene Joint de courant				1	1	1	
20	-	Styretransformer Control transformer 24V Steuerungstransformer Transformateur commande							
-	3821147	<b>200V Prim 1</b>							
-	3821148	<b>220V Prim 1</b>							
-	3821149	<b>380V Prim 1</b>							
-	3821150	<b>415V Prim 1</b>							
-	3821151	<b>440V Prim 1</b>							
-	3821153	<b>220-380V Prim 1-2</b>							
-	3821154	<b>220-440V Prim. 1-2</b>							
21	1805563	Låseskive Lock washer Scheibe Rondelle				2	2	2	
25	3812203	Endstop End stop Endverschluss Support arrière				1	1	1	
26	3821048	Endplade End plate   24.09.99 ⇒ Endplatte Plaque arrière				1	1	1	
27	3821030	Klemmerække Terminal clip   24.09.99 ⇒ Klemme Rangeé de bornes				1	1	1	
28	3807518	Klemmerække wk 4/4 Terminal clip Klemme Rangeé de bornes				3	3	3	
29	3821332	Endplade End plate Endplatte Plaque arrière				1	1	1	
30	-	Kontaktor Contactor 24V Schütz Contacteur							
-	3821404	CA3-16-10 ⇒ 31.12.99							
-	63910	CA3-16-10   01.01.00 ⇒							
-	3804168	CA3-23-10 ⇒ 31.12.99							
-	63907	CA3-23-10   01.01.00 ⇒							
-	63912	CA3-30-10							
-	3821218	CA3-16-01, CH							
33	3821212	Omskifter Reverser Y/Δ Umschalter 440/220 Inverseur				1	1	1	
34	6220737	Skala Dial 440/220 Skalen Echelle				1	1	1	
35	3806197	Tidskontakt Time switch CH Zeitschalter Contacttemporisé				1	1		
36	3806205	Hjælpekontakt Auxiliary switch CH Zusatzschalter Bouton auxiliaire				1	1		
37	3805371	Kondensator 80 µf 400 VDB Capacitor USA Kondensator Condensateur						1	
-	6101654	Kondensatorholder Capacitor holder Kondensatorhalter Condensateur sup.						1	
-	1119608	<b>Ledningsæt</b>				1	1	1	
-	1119609	<b>Kit for cables</b>	(1ph), USA						
-	1119610	<b>Kabelsatz</b> <b>Kit de câble</b> CH 2							

El-dele / Electric parts / Elektrische Teile / Pièces électrique  
03K

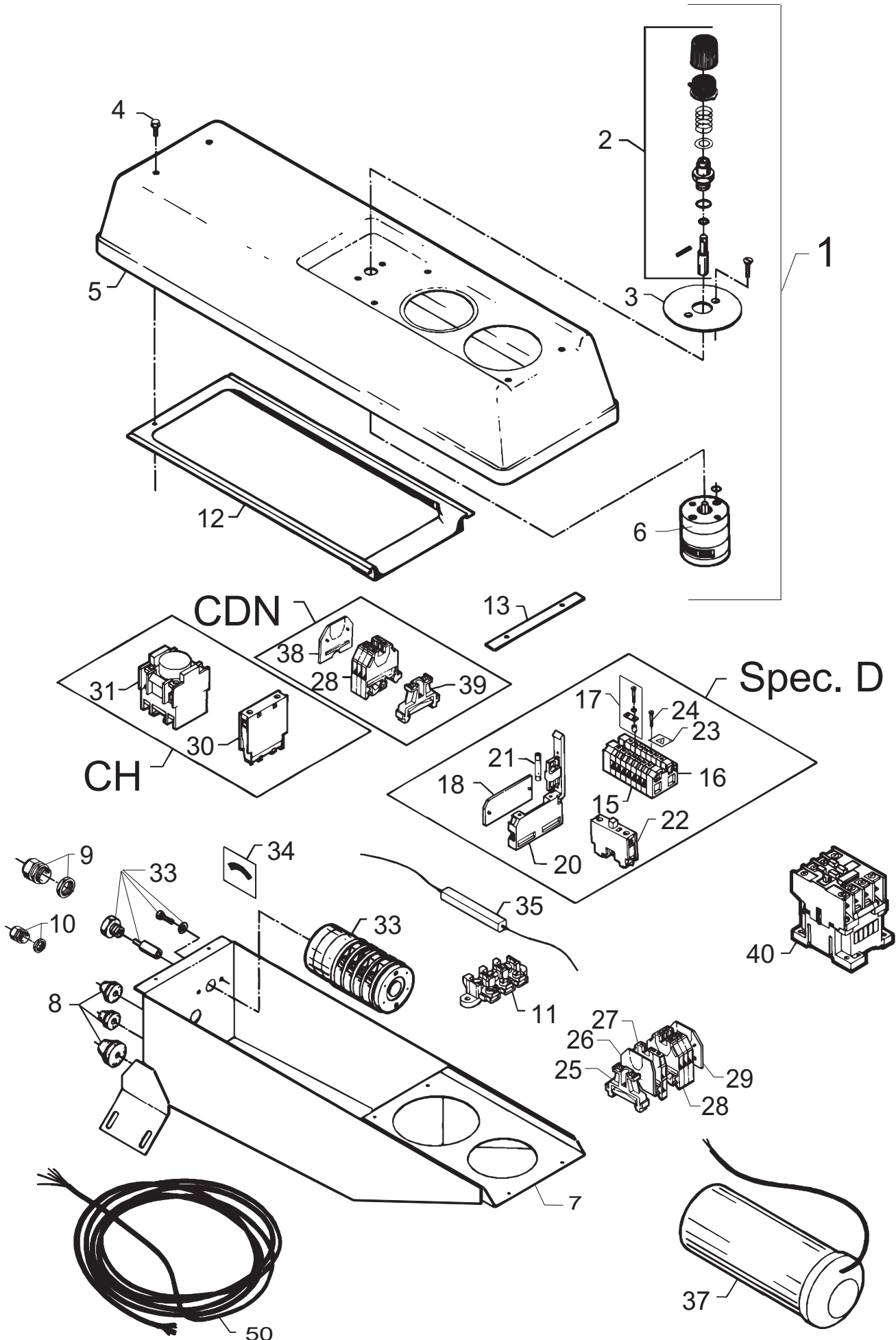

Pos. Ref.	Nr. No.	Betegnelse Bezeichnung	Designation Désignation	1903K	2903K	4403K	5203K	4003K	3000C
-	-	El-dele Electrical components Electrische Teile Pièces électrique	03K						
1	3804911	Start/stop kontakt, kompl Start/stop switch, compl. Start/Stop Schalter, kompl. Bouton marche/arrêt		x	x	x	x	x	x
2	1117357	Drejekontakt, kompl. Adjusting knob, compl. Drehshalter, kompl. Interrupteur à rotation		1	1	1	1	1	1
3	6101010	Skalaplade Dial plate Skalenplatte Echelle		1	1	1	1	1	1
4	1803956	Taptite skrue Taptite screw Taptiteschraube Vis Taptite	M4x12	6	6	6	6	6	6
5	-	Instrumentkasse, låg Instrument box, cover Instrumentengehäuse, Deckel Boîte à instrumente, couvercle							
-	6101400 6100129 6101054		Y/Δ CDN	1 1 1	1 1 1	1 1 1	1 1 1	1 1 1	1
6	3804895 3804903	Start/stop kontakt Start/stop switch Start/Stop Schalter Bouton marche/arrêt	D	x x	x x	x x	x x	x x	x x
7	-	Instrumentkasse Instrument box Instrumentengehäuse Boîte à instrumente							
-	6101656 6101605 6100128	24.09.99 ⇒ ⇒ 23.09.99   ⇒ 23.09.99	Y/Δ	1 1 1	1 1 1	1 1 1	1 1 1	1 1 1	1
8	-	Pakdåse Cable grommet Stopfbuchse Presse-étoupe							
-	3803764 3803772 3803780 3803798	TET 5 - 7C TET 7 - 10C TET 10 - 14C TET 14 - 20C	⇒ 23.09.99   ⇒ 23.09.99						
9	3830125	Kabelgennemføring Cable gland Kabeldurchführung Traversée	PG 21   24.09.99 ⇒	1	1	1	1	1	1
10	3830124	Kabelgennemføring Cable gland Kabeldurchführung Traversée	PG 16   24.09.99 ⇒	1	1	1	1	1	1
11	3803822	Klemmerække Terminal clip Klemme Rangeé de bornes	⇒ 23.09.99	1	1	1	1	1	1
12	6100115	Pakning f. instr. kasse Gasket f. instr. box Dichtung f. Instrumentengehäuse Joint p. boîte		1	1	1	1	1	1
13	6100116	Pakning Gasket Dichtung Joint		1	1	1	1	1	1
15	3800315	Klemmerække Terminal clip 3 ~ Klemme Rangeé de bornes	D		7	7	7		
16	3800323	Befæstigelsesblok Attachment block 3 ~ Befestigungsblock Bloc de fixation	D		2	2	2		

Pos. Ref.	Nr. No.	Betegnelse Bezeichnung	Designation Désignation	1903K	2903K	4403K	5203K	4003K	3000C
17	3800349	2 - pollet laske 2 - polar splice 3 ~ Zweipolige lasche Eclisse à deux pôles	D		1	1	1		
18	3804416	Afdækningsplade Cover plate 3 ~ Deckplatte Tôle protectrice	D		1	1	1		
20	3804333	Sikringsholder Fuse holder 3 ~ Sicherungshalter Support de fusible	D		2	2	2		
21	3804341	Sikring 1A 500V Fuse 3 ~ Sicherung Fusible	D		2	2	2		
22	3805280 - 3821738	Hjælpekontakt, D Auxiliary switch 3 ~ ⇒ 31.12.99   Zusatzschalter Bouton auxiliaire	01.01.00 ⇒		1	1	1		
23	3804325	Plade med lynsymbol Plate with symbol-lightning Platte mit Symbol-Blitz Plaque avec symbole-éclair	D		1	1	1		
24	1802784	Skrue, rød Screw, red Schraube, rot Vis, rouge	D		2	2	2		
25	3812203	Endstop End stop Endverschluß Support arrière	24.09.99 ⇒	1	1	1	1	1	1
26	3821048	Endplade End plate Endplatte Plaque arrière	24.09.99 ⇒	1	1	1	1	1	1
27	3821030	Klemmerække Terminal clip Klemme Rangeé de bornes	24.09.99 ⇒	1	1	1	1	1	1
28	3807518	Klemmerække wk 4/4 Terminal clip Klemme Rangeé de bornes	24.09.99 ⇒	3	3	3	3	2	3
28	14505	Klemmerække wk 4/4 Terminal clip Klemme Rangeé de bornes	10mm²						2
29	3821332	Endplade End plate Endplatte Plaque arrière	24.09.99 ⇒	1	1	1	1	1	1
30	3806205	Hjælpekontakt Auxiliary switch 3 ~ Zusatzschalter Bouton auxiliaire	CH			1	1		
31	3806197	Tidskontakt Time switch Zeitschalter Contacttemporisé	CH			1	1		
33	3806213 - 3812344	Omskifter Y/Δ Reverser Umschalter Inverseur	B (380/220) Off-shore (440/220)		x	x	x		x
34	6101574 - 6220737	Skala Dial Skalen Echelle	380/220 440/220		1	1	1		1
35	-	Modstand Resistance Widerstand Résistance							
-	3805165 - 3806171 - 3812955	8 K2, 5%-9W 6 K8, 5%-17W 8 K2, 5%-17W	B Off-shore, B Off-shore, USA						

El-dele / Electric parts / Elektrische Teile / Pièces électrique  
03K

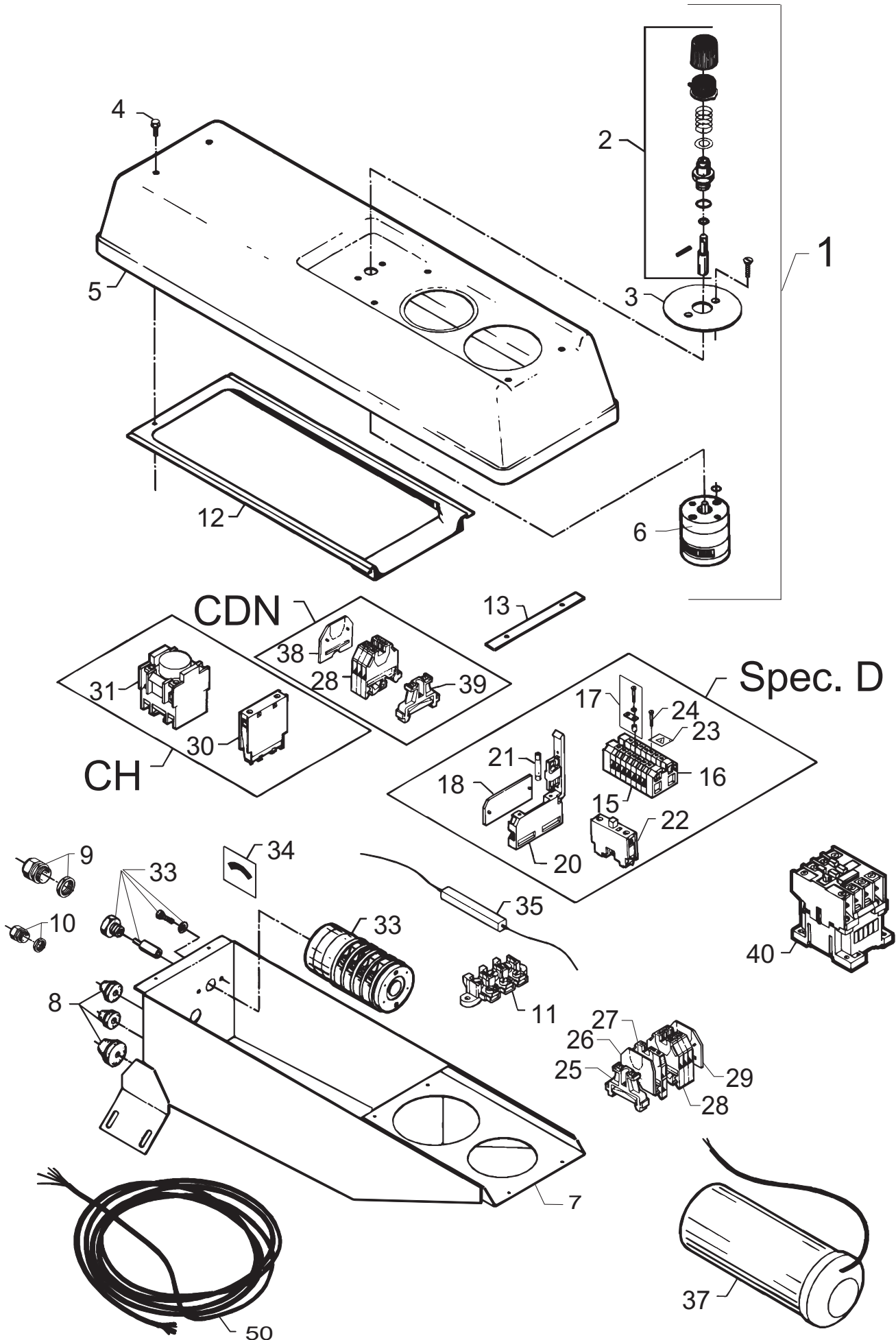

Pos. Ref.	Nr. No.	Betegnelse Bezeichnung	Designation Désignation	1903K	2903K	4403K	5203K	4003K	3000C
37	3805371	Kondensator Capacitor Kondensator Condensateur	80 µf 400 VDB USA, CDN	1	1	1	1	2	
37	3804267	Kondensator Capacitor, ø70IP5 Kondensator Condensateur	160 µf 240 VDB GB	2					
-	6101654	Kondensatorholder Capacitor holder Kondensatorhalter Support p.condensateur		1	1			1	
38	3807526	Endeplade End plate Endplatte Plaque arrière	CDN				1	1	
39	3805249	Endestop End stop Endverschluss Support arrière	CDN				2	2	
-	6101789	Kondensator sæt, start Capacitor kit, start-up Kondensator satz, Start Kit de condensateur, marche	CDN						
40	-	Kontaktor Contactor Schütz Contacteur	16A						
-	64881	400V, 50Hz/460V, 60Hz			1	1	1		
40	-	Kontaktor Contactor Schütz Contacteur	CA3-16-10						
	3804028	190V, 50Hz / 220V, 60Hz J, off-shore 3x220V		1					
	3804036	346V, 50Hz HK, SGP		1	1	1			
	65856	500V, 50Hz / 575V, 60Hz S, CDN					1		
40	-	Kontaktor, 23A 50-60Hz Contactor Schütz Contacteur	CA3-23-10						
	3804101	220V, 50Hz / 254V, 60Hz B, N ⇒ 31.12.99				1			
	3804119	190V, 50Hz / 220V, 60Hz J, Off-shore 3x220V ⇒ 31.12.99				1			
	63910	220V, 50Hz / 254V, 60Hz 190V, 50Hz 220V, 60Hz J, Off-shore 3x220V	B, N  01.01.00 ⇒					1	
40	-	Kontaktor, 23A Contactor Schütz Contacteur	CA3-23-10						
	3804150	380V, 50Hz I			1				

Pos. Ref.	Nr. No.	Betegnelse Bezeichnung	Designation Désignation	1903K	2903K	4403K	5203K	4003K	3000C
40	-	Kontaktor, 30A 50-60Hz Contactor Schütz Contacteur	CA3-30-10						
	63914	190V, 50Hz / 220V, 60Hz 5203K : J					1		
	3804184	110V, 50Hz / 127V, 60Hz 1x110V: GB		1					
	63914	220V, 50Hz / 254V, 60Hz B, N, Off-shore 3x220V, USA 3x220V, CDN, U, ROK			1	1	1	1	1
40	3804747	Kontaktor, 400V,50Hz Contactor Schütz Contacteur	CA3-16-10 Y/Δ				1	1	
50	-	EI-kabel EI.cable Anschlußkabel Câble électrique							
	-	6100482 H05VV-F 4G 1.5			x	x	x		
	-	6100483 H05VV-F 4G 2.5				x	x		
	-	6100488 H07RN-F 4G 2.5				x	x		x
	-	6100490 H07RN-F 5G 1.5							
	-	6100478 AO6VV-F 4G 5.5	J					x	
	-	6180260 H07RN-F 4G 1.5			x	x	x		
	-	6180261 H07RN-F 3G 1.5			x	x	x		
	-	6180268 H07RN-F 3G4		x	x				
	-	65484 SOW AWG 10/4 US					x		
	-	65149 SOW AWG 10/3 US						x	
52	-	Stik Plug Stecker prise électrique							
	-	3802493 CEE 5 pol. 380V/16A							
	-	3805793 1 pol. Eur.							
	-	3805603 L6-30P 240V/30A	CDN					x	
	-	3805629 L15-30P 240V/25A	CDN					x	
	-	3805611 L16-20P 575V/9A	CDN					x	