

40H/HA 40HA MASTER

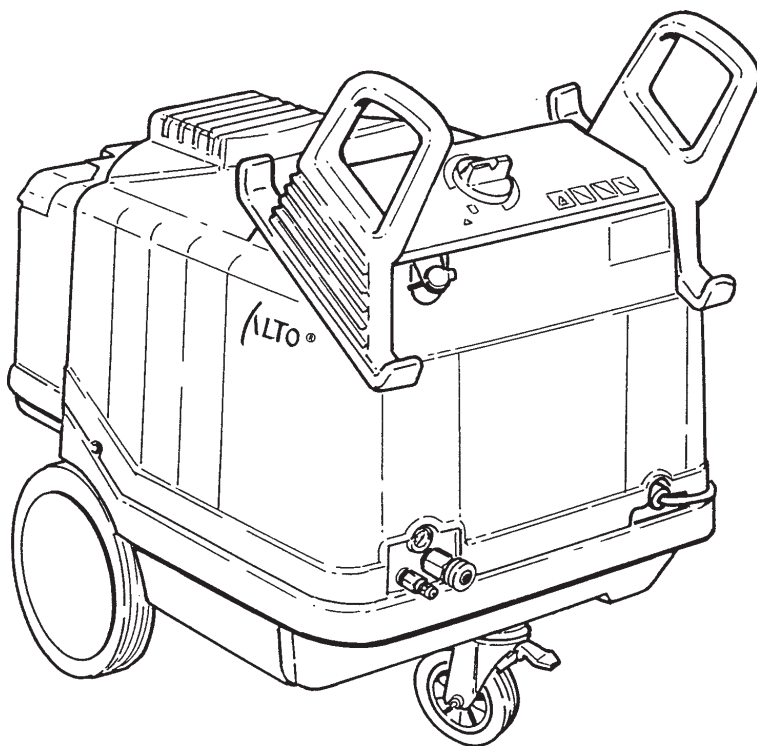

ALTO®

Total Cleaning
Confidence™

Reservedele
Spare parts
Ersatzteile
Pièces détachées

598 51 50 - 00.09

3 INDEX
1

WAP
KEW
TECHNOLOGIES

"Positionsnummer" der henviser til tegning.
 "Reference number" which refers to drawing.
 "Positionsnummer", die auf Zeichnung hinweist.
 "Numéro de repaires" qui se réfère au plan.

"Produktbetegnelse"
 "Product designation"
 "Produktbezeichnung"
 "Désignation du produit"

Pos. Ref.	Nr. No.	Betegnelse Bezeichnung	Designation Désignation	0840H/HA	1640H/HA	1840H/HA	3040H/HA	3840H/HA	MASTER
10	1813385	Skrue Screw Schraube Vis	M8x60	2	2	2	2	2	2
11	6184920	Møtrik Nut Mutter Ecrou		2	2	2	2	2	2
12	6184938	Kabinethængsel, komplet - venstre Cabinet hinge, compl. - left Gehäusescharnier, kompl. - links Barre de capot, compl. - gauche		1	1	1	1	1	1
13	6184937	Kabinethængsel, komplet - højre Cabinet hinge, compl. - right Gehäusescharnier, kompl. - rechts Barre de capot, compl. - droite		1	1	1	1	1	1
14	6184106	„No Scale“ beholder „No Scale“ container „No Scale“ Behälter Réservoir d'„No Scale“		1	1	1	1	1	1
15	1119216	Rep.sæt, indikator Rep. kit, indicator Rep.satz, Indikator Kit de rép, indicateur		x	x	x	x	x	x

"Reparationssæt" indeholder udvalgte reservedele, der er indrammet på tegningen.

"Repair kits" contain selected spare parts, which are boxed in on drawing.

"Reparatursätze" enthalten ausgewählte Ersatzteile, die auf der Zeichnung eingerahmt sind.

"Kit de réparation" contient des pièces détachées sélectionnées, qui sont encadrées sur le plan.

Angiver **antal** dele der indgår i maskinen/ hovedkomponenten.
 Et "x" angiver at artiklen indeholder dele, der også forhandles som løse dele.

States the **number** of parts which form part of the machine/main component.
 An "x" states that the article contains parts, which are also available as separate parts.

Gibt **Anzahl** Teile an, die im Gerät/in den Hauptkomponenten eingehen.
 Ein "x" gibt an, daß der Artikel Teile enthält, die auch als Ersatzteile verhandelt werden.

Nombre de parts qui font partie du composant primaire.
 Une "x" dit, que l'article contient des pièces, qui sont aussi vendus séparément.

40H/HA

40HA MASTER

Reservedele • Spare parts
Ersatzteile • Pièces détachées

Indholdsfortegnelse Index Inhaltsverzeichnis Sommaire

Side Page Seite Page	Betegnelse Designation Bezeichnung Désignation
4 - 7	Kabinet (oversigt) Cabinet (summary) Gehäuse (Übersicht) Capot (synoptique)
8 - 13	Motorpumpeenhed Motor pump unit Motorpumpeneinheit Corps de pompe (moteur)
14 - 17	El-dele Electrical components Elektrische Komponenten Éléments électriques
18 - 21	Kedel Boiler Kessel Chaudière
20 - 21	Strømningskontakt Flow switch Strömungsschalter Circulation sélecteur
22 - 23	Brændstoftank Fueltank Brennstofftank Réservoir du fuel
24 - 27	Svømmerhuslæg, afgang & tilgang Cover f. float chamber, outlet & inlet Deckel f. Schwimmergehäuse, Auslaß & Einlaß Couvercle p. bac à flotteur, départ & entrée

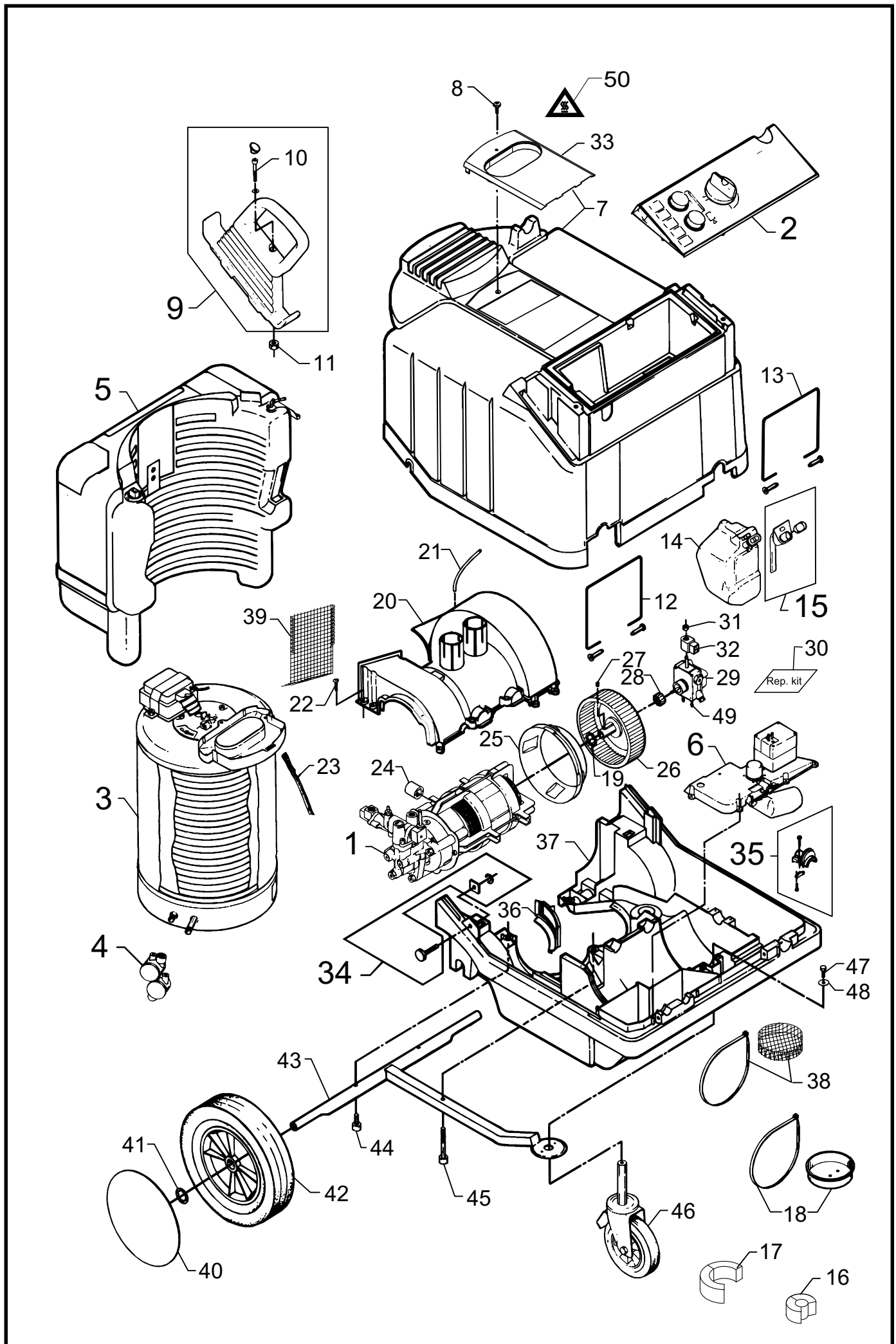

Pos. Ref.	Nr. No.	Betegnelse Bezeichnung	Designation Désignation						
				0840/H/A	1640/H/A	1840/H/A	3040/H/A	3840/H/A	MASTER
1	-	Motorpumpehed Motor pump unit Motorpumpeneinheit Corps de pompe		Se side 7 See page 7 Siehe Seite 7 Voir page 7					
2	-	El-dele Electrical components Elektrische Komponenten Éléments électriques		Se side 13 See page 13 Siehe Seite 13 Voir page 13					
3	-	Kedel Boiler Kessel Chaudière		Se side 17 See page 17 Siehe Seite 17 Voir page 17					
4	-	Strømningskontakt Flow switch Strömungsschalter Circulation sélecteur		Se side 19 See page 19 Siehe Seite 19 Voir page 19					
5	-	Brændstoftank Fuel tank Brennstofftank Réservoir du fuel		Se side 23 See page 23 Siehe Seite 23 Voir page 23					
6	-	Svømmerhuslåg Cover f. float chamber Deckel f. Schwimmergehäuse Couvercle p. bac à flotteur		Se side 25 See page 25 Siehe Seite 25 Voir page 25					
7	6185942	Kabinet m. kedelskjold Cabinet w. boiler shield Gehäuse m. Kesselschutzschirm Capot avec jupon chaudière		1	1	1	1	1	1
8	6184116	Skrue Screw Schraube Vis	M6x14	1	1	1	1	1	1
9	1119211	Rep.sæt, Kørehåndtag H & V Rep. kit, steering handle R + L Rep.satz, Handbügel R + L Kit, poignée de guidage D+G		x	x	x	x	x	x
10	1813385	Skrue Screw Schraube Vis	M8x60	2	2	2	2	2	2
11	6184920	Møtrik Nut Mutter Ecrou		2	2	2	2	2	2
12	6184938	Kabinethængsel, komplet - venstre Cabinet hinge, compl. - left Gehäusescharnier, kompl. - links Barre de capot, compl. - gauche		1	1	1	1	1	1
13	6184937	Kabinethængsel, komplet - højre Cabinet hinge, compl. - right Gehäusescharnier, kompl. - rechts Barre de capot, compl. - droite		1	1	1	1	1	1
14	6184106	„No Scale“ beholder „No Scale“ container „No Scale“ Behälter Réservoir d'„No Scale“		1	1	1	1	1	1
15	1119216	Rep.sæt, indikator Rep. kit, indicator Rep.satz, Indikator Kit de rép, indicateur		x	x	x	x	x	x
16	1119388	Propsæt Plug kit Pfropfsatz Kit de bouchon		1	1	1			
17	1119399	Propsæt Plug kit Pfropfsatz Kit de bouchon						1	1
18	1119259	Propsæt (98) Plug kit (98) Pfropfsatz (98) Kit de bouchon (98)		1					
19	6184408	Afstandsstykke Spacer Distanzstück Pièce d'espace		1	1	1	1	1	1
20	6184056	Blæserhus Fan housing Gehäuse f. Gebläse Carter ventilateur		1	1	1	1	1	1

Pos. Ref.	Nr. No.	Betegnelse Bezeichnung	Designation Désignation						
				0840/H/A	1640/H/A	1840/H/A	3040/H/A	3840/H/A	MASTER
21	2450008	Indikatorslange Indicator hose Indikatorschlauch Tuyau p. indicateur	800mm			1	1		
22	1813989	Skrue Screw Schraube Vis	35x16 RF	11	11	11	11	11	11
23	6184736	Strop Belt Reimen Sangle		1	1	1	1	1	1
24	6184676	Gummiophæng Vibration damper Schwingungsdämpfer Amortisseur de vibration		4	4	4	4	4	4
25	6184404	Luftragt Air-funnel Luftricht Plaque d'aération		1	1	1	1	1	1
26	6184405	Blæserhjul Impeller Gebläserad Ventilateur		1	1	1	1	1	1
27	1800325	Pinolskrue Screw Schraube Vis		1	1	1	1	1	1
28	6184279	Kobling for oliepumpe Coupling for oil-pump Kupplung Accouplement		1	1	1	1	1	1
29	3821320	Oliepumpe, m. spole Oil-pump, with coil (Danfoss) Brennstoffpumpe, m. Spule Pompe à fuel, a. bobine		x	x	x	x	x	x
-	6184943	Oliepumpe, m. spole Oil-pump, with coil Brennstoffpumpe, m. Spule Pompe à fuel, a. bobine	CDN CDN (Suntec) CDN	x	x	x	x		
30	1119214	Rep.sæt, Filter & pakning Kit, Screen & gasket Rep.satz, Filter & Dichtung Kit de rép, Filtre & joint	(Suntec)	x	x	x	x		
30	1119217	Rep.sæt, Filter & pakning Kit, Screen & gasket Rep.satz, Filter & Dichtung Kit de rép, Filtre & joint	(Danfoss)	x	x	x	x	x	x
31	1814045	Møtrik Nut Mutter Ecrou	(Suntec)	1	1	1	1		
32	3820305	Spole Coil Spule Bobine	(Suntec)	1	1	1	1		
-	3821089	Spole, med møtrik og skive Coil, with nut and washer Spule, mit Mutter und Scheibe Bobine, a. écrou + rondelle	(Danfoss)	1	1	1	1	1	1
33	6184329	Kedelskjold Boiler shield Kesselschutzschirm Jupon chaudière	01.01.99 =>	1	1	1	1	1	1
34	1119218	Rep.sæt, kabinetskrue Rep. kit, cabinet screw Rep.satz, Gehäuse schraube Kit de rép, Vis p. capot		x	x	x	x	x	x
35	1119219	Rep.sæt, kabelafastning Rep. kit, Cable lead-in Rep.satz, Zugentlastung Kit, Despositif d'attaque auxil.		x	x	x	x	x	x
36	6184403	Blæsertætning Fan tightening Gebläse dichtung Joint p. ventilateur		1	1	1	1	1	1
37	6184058	Chassis Chassis Chassis Châssis		1	1	1	1	1	1

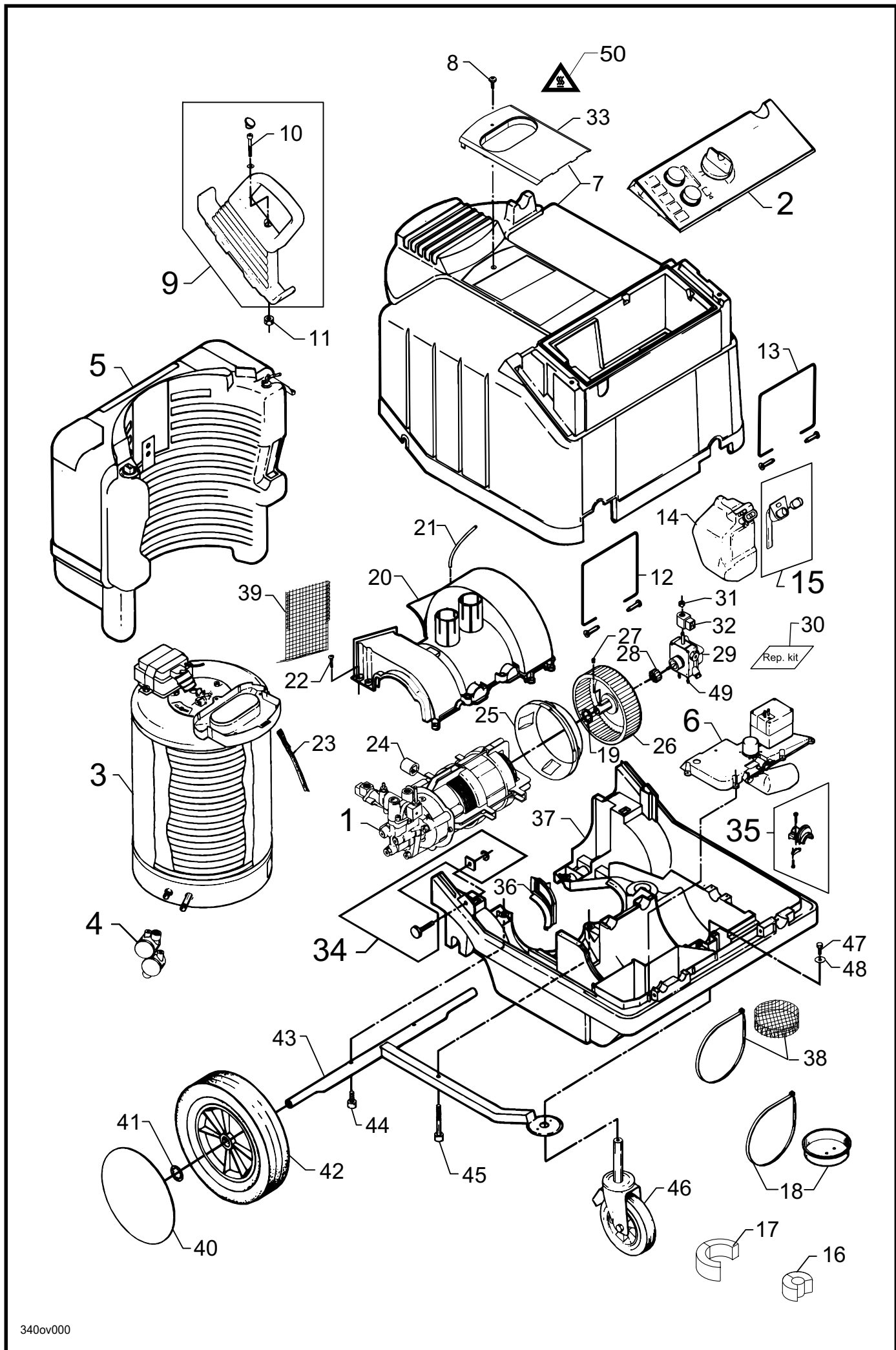



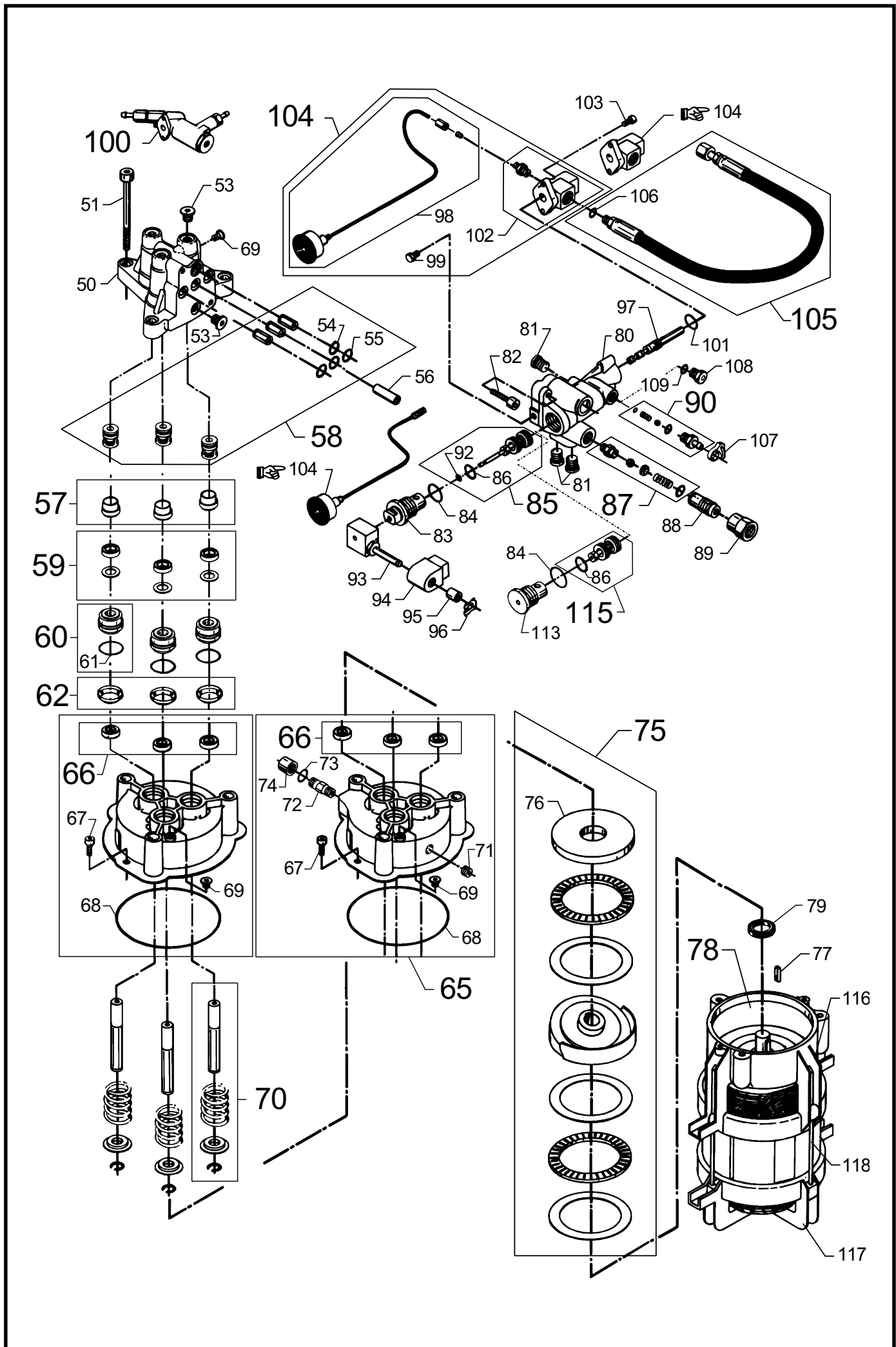

340ov000

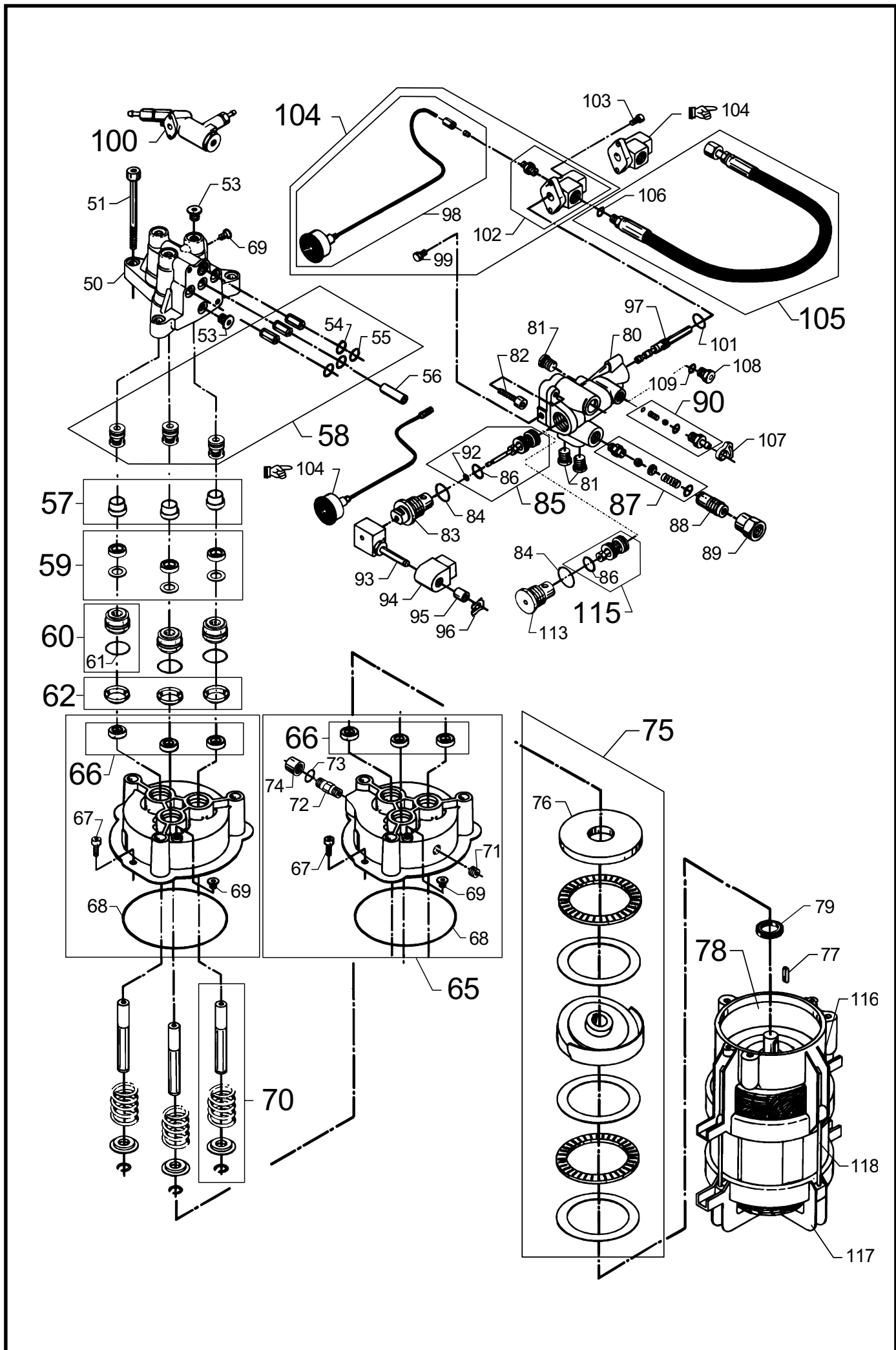

Pos. Ref.	Nr. No.	Betegnels Bezeichnung	Designation Désignation	0840H/HA	1640H/HA	1840H/HA	3040H/HA	3840HA	MASTER
1	-	Motorpumpehed Motor pump unit Motorpumpeneinheit Corps de pompe		x	x	x	x	x	x
50	6187132	Topstykke Cylinder head Zylinderkopf Culasse		1	1	1	1	1	1
51	1813393	Skrue Screw, Insex Schraube Vis	M10x100	3	3	3	3	3	3
53	6180906	Prop m. o-ring Plug with o-ring Pfropfen mit o-ring Manchon a. joint torique		3	3	3	3	3	3
54	3001807	O-ring O-ring O-Ring Joint torique		1	1	1	1	1	1
55	3001070	O-ring O-ring O-Ring Joint torique		3	3	3	3	3	3
56	6120624	Afstandsboesning Spacer Distanzhülse Douille d'écartement		1	1	1	1	1	1
57	6183050	Afstandsstykke (3 stk.) Spacer (3 pcs.) Distanzstück (3 Stck.) Pièce d'espace (3 pcs.)		1	1	1	1	1	1
58	1119209	Rep.sæt, ventilsystem Rep. kit, valvesystem Rep.satz, Ventilsystem Kit de système de clapet		x	x	x	x	x	x
59	1119212	Rep.sæt, Støttering/U-manchet Rep. kit, Back-up ring/U-seal Rep.satz, Stützring/U-Manschette Kit, Anneau d'appui/U-raccord		1	1	1	1	1	1
60	6180910	Trykring, kompl. Thrust collar, compl. Druckring, Kompl. Anneau d'arrêt, compl.		3	3	3	3	3	3
61	3004009	O-ring O-ring O-Ring Joint torique		3	3	3	3	3	3
62	6183051	Afstandsstykke (3 stk.) Spacer (3 pcs.) Distanzstück (3 Stck.) Pièce d'espace (3 pcs.)		1	1	1	1	1	1
65	6180947	Cylinderblok, kompl. Cylinderblock 19.04.99 => Zylinderblock, kompl. Carter-cylindre, compl.		x	x	x	x	x	x
-	6180911	Cylinderblok, kompl. Cylinderblock, compl. Zylinderblock, kompl. Carter-cylindre, compl.		x	x	x	x	x	x
66	1117642	U-manchet (3 stk.) U-seal (3 pcs.) U-Manschette (3 Stck.) Joint huile (3 pcs.)		1	1	1	1	1	1
67	1814573	Skrue Screw Insex Schraube Vis	M6x35	2	2	2	2	2	2
68	3003886	O-ring O-ring O-Ring Joint torique	120,4x1,78	1	1	1	1	1	1
69	6180912	Prop m. O-ring Plug with O-ring Pfropfen mit O-Ring Manchon a. joint torique		2	2	2	2	2	2

Pos. Ref.	Nr. No.	Betegnels Bezeichnung	Designation Désignation	0840H/HA	1640H/HA	1840H/HA	3040H/HA	3840HA	MASTER
70	-	Rep.sæt, keramikstempel Rep. kit, ceramic piston Satz, Keramischer druckkolben Kit de piston ceramique							
-	1119201	0840H/HA 1640H/HA (1440H) 2340HA (1840H/HA,60Hz)		3	3				
-	1119202	3040H/HA 3840HA (1840H/HA,50Hz) 40HAMASTER				3	3		3
71	1602325	Rørprop Plug 19.04.99 => Pfropfen Boucon		1	1	1	1	1	1
72	6184810	Gevindestykke 1/4 Threaded piece 19.04.99 => Gewindestück 1/4" Pièce avec filetage 1/4"		1	1	1	1	1	1
73	3002185	O-ring O-ring 19.04.99 => O-Ring Joint torique		1	1	1	1	1	1
74	6184807	Slutmuffe Sealing cap 19.04.99 => Verschlusskappe Bouchon		1	1	1	1	1	1
75	-	Rep.sæt, skraskive/lejer Rep. kit, wobble disc/bearings Rep.satz, Taumelscheibe/Lager Kit, disque oblique/roulements							
-	1119205	0840H/HA, 60Hz => 01.03.94 USA, CDN		x					
-	1119649	0840H/HA, 60Hz 01.03.94 => USA, CDN		x					
-	1119226	1640H/HA, 50Hz => 01.01.94			x				
-	1119648	1640H/HA, 50Hz 01.01.94 =>			x				
-	1119220	1640H/HA, 50Hz => 01.01.94 GB			x				
-	1119221	1840H/HA, 50Hz => 02.10.95				x			
-	1119681	1840H/HA, 50Hz 02.10.95 =>				x			
-	1119222	3040H/HA, 50Hz => 02.10.95					x		
-	1119688	3040H/HA, 50Hz 02.10.95 =>					x		
-	1119656	3840HA, 50Hz						x	
-	1119656	40HAMASTER							x
-	1119223	1640H/HA, 60Hz => 01.03.94 1440H, 50Hz (IRL) => 01.01.94 1640H/HA, 60Hz 01.03.94 => 1440H, 50Hz (IRL) 01.01.94 =>			x (x) x (x)				
-	1119224	1840H/HA, 60Hz => 01.03.94				x			
-	1119647	1840H/HA, 60Hz 01.03.94 =>				x			
-	1119826	2340HA, 60Hz							
-	1119225	3040H/HA, 60Hz => 02.10.95					x		
-	1119689	3040H/HA, 60Hz 02.10.95 =>					x		
-	1119655	3840HA, 60Hz						x	
-	1119655	40HAMASTER							x
76	6181518	Lejeskive, 3 ~ Bearing track 02.10.95 Lagerscheibe				1	1		
-	6182479	Rondelle de palier 02.10.95 =>				1	1	1	1
76	-	Lejeskive, 1~ Bearing track Lagerscheibe Rondelle de palier							
-	6181518	1~, 50Hz => 01.01.94		1	1	1			
-	6181518	1~, 60Hz => 01.03.94		1	1	1			
-	6182479	1~, 50Hz 01.01.94 =>		1	1	1			
-	6182479	1~, 60Hz 01.03.94 =>		1	1	1			
77	3202421	Feder Key Federkeil Clavette		1	1	1	1	1	1



Pos. Ref.	Nr. No.	Betegnelse Bezeichnung	Designation Désignation	0840/H/HA	1640/H/HA	1840/H/HA	3040/H/HA	3840/HA	MASTER	
78	-	El-motor m. feder El.motor w. key El-Motor m. Federkeil El. moteur avec clavette		Se side 13 See page 13 Siehe Seite 13 Voir page 13						
79	1119671	Rep.sæt, akseltætningsring Rep.kit, sealing ring for shaft Rep.satz, Wellendichtungsring Kit, joint annulaire p. arbre		1	1	1	1	1	1	
80	6181477	Ventilhus Valve housing Ventilgehäuse Carter-by pass		1	1	1	1	1	1	
81	6180913	Blændprop m. o-ring Hole plug w. o-ring Verschlußpfropfen m. o-Ring Bouchon a. joint torique		3	3	3	3	3	3	
82	1803345	Skrue Screw Insex Schraube Vis	M8x30	2	2	2	2	2	2	
83	6184525	Prop Plug Pfropfen Bouchon		1	1	1	1	1	1	
84	3001963	O-ring O-ring O-Ring Joint torique		1	1	1	1	1	1	
85	1119227	Rep.sæt, ventilmekle Rep. kit, piston Rep.satz, Kolben Kit de rép, piston	 H	1	1	1				
-	1119247	Rep.sæt, ventilmekle Rep. kit, piston Rep.satz, Kolben Kit de rép, piston	 HA	1	1	1				
-	1119228	Rep.sæt, ventilmekle Rep. kit, piston Rep.satz, Kolben Kit de rép., piston	 H				1			
-	1119248	Rep.sæt, ventilmekle Rep. kit, piston Rep.satz, Kolben Kit, piston - (2340HA)	 HA				1	1	1	
86	3003860	O-ring O-ring O-Ring Joint torique		1	1	1	1	1	1	
87	1118512	Rep.sæt, sikkerhedsventil Rep. kit, Safety valve Rep.satz, Sicherheitsventil Kit de rép., soupape de sûreté		1	1	1	1	1	1	
88	6100940	Justerskrue Adjustment screw Justierschraube Vis de réglage		1	1	1	1	1	1	
89	6100928	Kontramøtrik Lock nut Gegenmutter Contre écrou		1	1	1	1	1	1	
90	1119406	Rep.sæt, kontraventil Rep. kit, non return valve Rep.satz, Rückschlagventil Kit de rép., clapet anti retour		1	1	1	1			
92	3000387	O-ring O-ring O-Ring Joint torique		1	1	1	1	1	1	
93	6184930	Damptrin Steamstage Dampfstufe Etagé vapeur		1	1	1	1	1	1	
94	3820305	Spole Coil Spule Bobine	(Suntec)	1	1	1	1	1	1	
95	6184533	Bøsning Bush Buchse Baque		1	1	1	1	1	1	

Pos. Ref.	Nr. No.	Betegnelse Bezeichnung	Designation Désignation	0840/H/HA	1640/H/HA	1840/H/HA	3040/H/HA	3840/HA	MASTER	
96	1813591	Låseclips Lock clip Schließring Circlip		1	1	1	1	1	1	
97	6180916	Injektordyse med O-ring Injectornozzle w. O-ring Injektordüse m. O-Ring Buse de l'injecteur a. joint torique		1	1	1	1	1	1	
98	6184949	Manometer, komplet Pressure gauge, compl. Manometer, kompl. Manomètre, compl.		1	1	1	1	1	1	
99	6181542	Blændprop ø4 Plug ø4 Verschlußpfropfen ø4 Bouchon ø4	40H	1	1	1				
100	-	Hus f. automatisk start/stop Auto start/stop housing Gehäuse Auto Start/Stop Carter marche/arrêt auto		Se side 13 See page 13 Siehe Seite 13 Voir page 13						
101	3001674	O-ring O-ring O-Ring Joint torique		1	1	1	1	1	1	
102	6184934	Afgangsvinkel, komplet Outlet elbow, compl. Auslaßwinkel, kompl. Coude du dépats, compl.		1	1	1	1	1	1	
103	1813484	Skrue Screw Schraube Vis	M6x16	2	2	2	2	2	2	
104	1119691	Opgraderingskit for manometer Upgrade kit f. pressure gauge 40H Aufgradierungssatz f. Manometer Kit d'amélioration p. manomètre		x	x	x				
-		For renser produceret før 02.03.92 For cleaners produced until 02.03.92 Für reiniger, die bis 02.03.92 hergestellt worden sind Pour les appareils fabriqués avant 02.03.92								
105	1450000	Intern højtryksslange, komplet Internal h.p. hose, compl. Interner Hochdruckschlauch Tuyau h.p. interne, compl.		x	x	x	x	x	x	
106	3000072	O-ring O-ring O-Ring Joint torique		1	1	1	1	1	1	
107	1814029	Slangeklemme Hose clip Schlauchschele Collier de serrage		1	1	1	1			
108	6105533	Prop Plug Pfropfen Manchon							1 1	
109	3000072	O-ring O-ring O-Ring Joint torique							1 1	
113	6180650	Prop - uden damptrin Plug - without heating stage Pfropfen - ohne Dampfstufe Bouchon - sans étage de vapeur					1			
115	6184941	Rep.sæt, ventilmekle u. damptrin Kit, piston w/u heating stage Rep.satz, Kolben ohne Dampfstufe Kit, piston sans étage de vapeur					1			
116	6180948	D-lejedæksel Front bearing cover D-Lagerdeckel AV-flasque de carter		1	1	1	1	1	1	
117	6180949	N-lejedæksel Rear bearing cover N-Lagerdeckel AR-flasque de carter		1	1	1	1	1	1	
118	6180939	Stagbolt Stud Stehbolzen Entretoise		4	4	4	4	4	4	

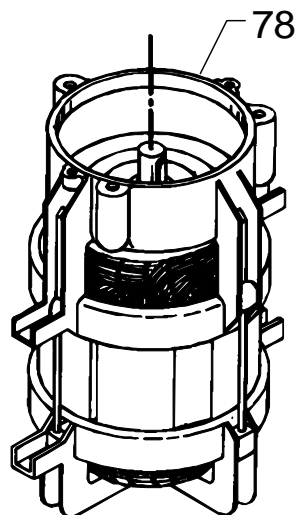
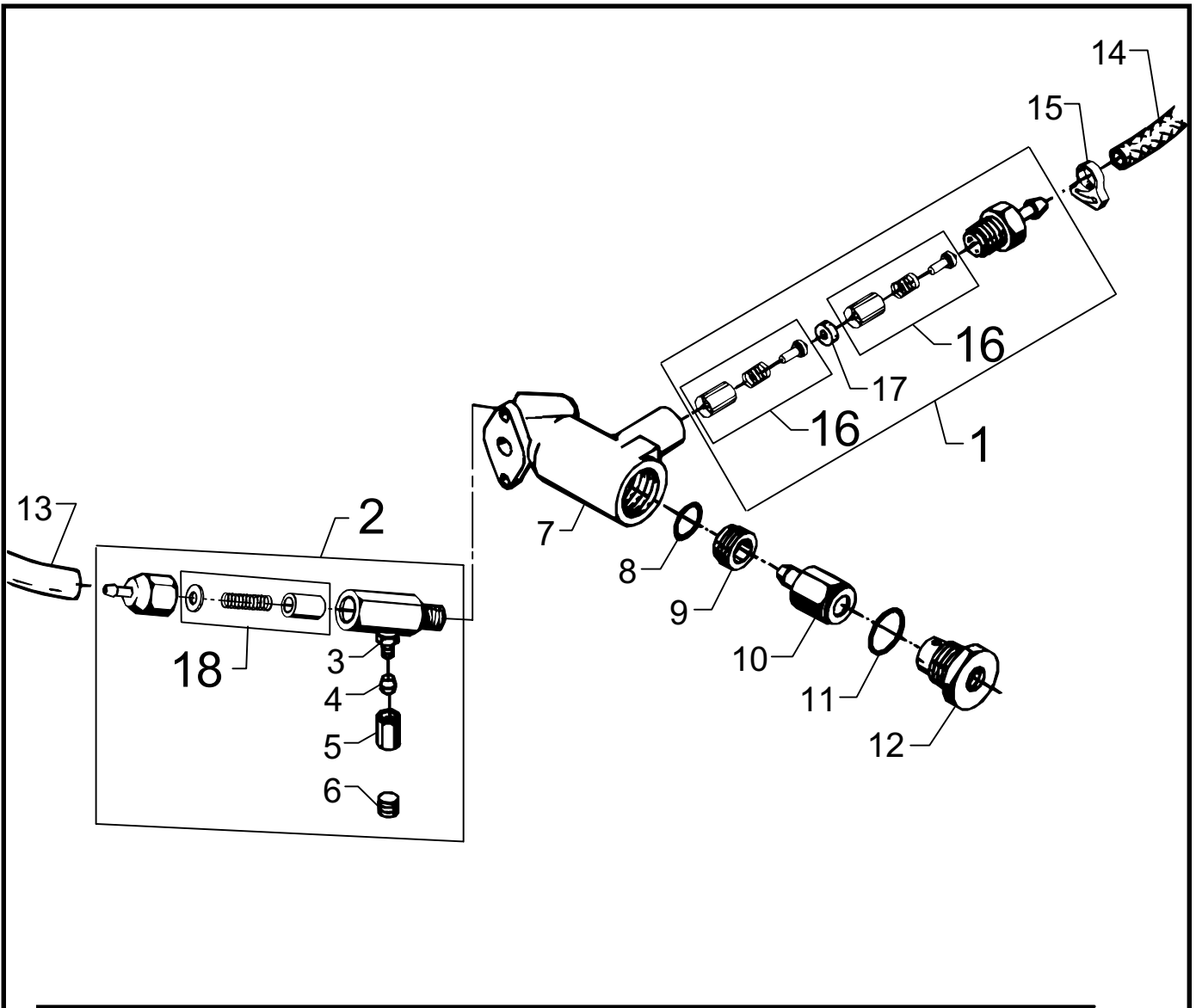

Pos. Ref.	Nr. No.	Betegnelse Bezeichnung	Designation Désignation	0840/H/A	1640/H/A	1840/H/A	3040/H/A	3840/H/A	MASTER
100	-	Hus f. automatisk start/stop Auto start/stop housing, compl. Gehäuse Auto Start/Stop Carter marche/arrêt auto		HA	HA	HA	HA	HA	HA
1	1119318	Rep.sæt, kontraventil S/S Kit, non return valve Rep.satz, Rückschlagventil S/S Kit, clapet anti retour m./a.	Start/Stop	x	x	x	x	x	x
2	1119288	Rep.sæt, udluftningsventil Rep. kit, venting valve Rep.satz, Entlüftungsventil Kit de rép., clapet de purge		x	x	x	x	x	x
3	1603422	Forskruing 1/8" - ø4 Threaded connection 1/8" - ø4 Verschraubung 1/8" - ø4 Raccord fileté 1/8" - ø4		1	1	1	1	1	1
4	1603448	Skærering Cutting ring Schneidring Anneau		1	1	1	1	1	1
5	1603430	Omløber ø4 Union nut ø4 Überwurfmutter ø4 Ecrou ø4		1	1	1	1	1	1
6	1602333	Blændpop 1/8" Hole plug 1/8" Verschlusspfropfen 1/8" Bouchon 1/8"		1	1	1	1	1	1
7	6401819	Hus f. automatisk start/stop Auto start/stop housing Gehäuse Auto Start/Stop Carter marche/arrêt auto		1	1	1	1	1	1
8	3001112	O-ring O-ring O-Ring Joint torique		1	1	1	1	1	1
9	6201534	Sæde f. aflastningsventil Seat f. relief valve Sitz f. Entlastungsventil Siège de soupape de détente		1	1	1	1	1	1
10	6350463	Stempel f. aflastningsventil, kompl. Piston f. relief valve, compl. Kolben f. Entlastungsventil, kompl. Piston de soupape de détente		1	1	1	1	1	1
11	3000825	O-ring O-ring O-Ring Joint torique		1	1	1	1	1	1
12	6401817	Tilslutningsprop Connecting union Anschlusspfropfen Raccord		1	1	1	1	1	1
13	2450010	Slange 1/4" Hose 1/4" Schlauch, 1/4" Tuyau, 1/4"		1	1	1	1	1	1
14	2406357	Slange, blå 1/4" Hose, blue 1/4" Schlauch, blau 1/4" Tuyau, bleu 1/4"		1	1	1	1	1	1
15	1801034	Slangeklemme Hose clip Schlauchschelle Collier de serrage	13mm	2	2	2	2	2	2
16	1119566	Rep.sæt, kontraventil Rep. kit, nonreturn valve Rep.satz, Rückschlagventil Kit de rép., clapet anti-retour		2	2	2	2	2	2
17	6201535	Sæde Seat Sitz Siège		1	1	1	1	1	1
18	1119317	Rep.sæt, udluftningsventil Rep.Kit, venting valve Rep.satz, Entlüftungsventil Kit de rép., vis de purge		1	1	1	1	1	1

Pos. Ref.	Nr. No.	Betegnelse Bezeichnung	Designation Désignation	0840/H/A	1640/H/A	1840/H/A	3040/H/A	3840/H/A	MASTER
78	-	El-motor m. feder El. motor w. key El-Motor m. Federkeil El. moteur avec clavette	50Hz						
-	6183394	1x220/230 V, 50 Hz			1				
-	6183392	1x240 V, 50 Hz			1				
-	6183393	3x415/440 V, 50 Hz					1		
78	-	El-motor m. feder El. motor w. key El-Motor m. Federkeil El. moteur avec clavette	60Hz						
-	6183404	1x115 V, 60 Hz	USA, CDN	1					
-	6183403	1x220 V, 60 Hz			1	1			
-	6183402	1x220 V, 60 Hz	USA, CDN			1			
-	6183408	1x220 V, 60 Hz	(2340HA)						
-	6183395	3x220 V, 60 Hz 3x230 V, 60 Hz 3x220/440, 60 Hz	USA, CDN				1		
-	6180400	Use + 6183390: 3x380-440 V, 60 Hz			1	1			
78	-	El-motor m. feder El. motor w. key El-Motor m. Federkeil El. moteur avec clavette	50/60Hz						
-	6183398	3x200 V, 50 Hz 3X200V, 60 Hz				1			
-	6183391	3x380/220 V, 50 Hz 3x380/220 V, 60 Hz			1				
-	6183396	3x200 V, 50 Hz 3X200V, 60 Hz				1			
-	6183390	3x380/220V, 50 Hz 3x380-440 V, 60 Hz					1		
-	6183405	3x400/230 V, 50 Hz 3x440/220 V, 60 Hz						1	1
-	6183407	3x415 V, 50Hz						1	1
-	6183399	1x110 V, 50Hz			1				
-	-	Instruktionsbog Instruction manual Betriebsanleitung Livret d'instructions							
-	6189413	DK-N-S-SF						x	x
-	6189414	GB-D-F-NL-E-P-I-GR						x	x
-	6189446	DK-N-S-SF		x	x	x	x		
-	6189447	GB-D-F-NL-E		x	x	x	x		
-	6189448	USA							
-	6189449	CDN							

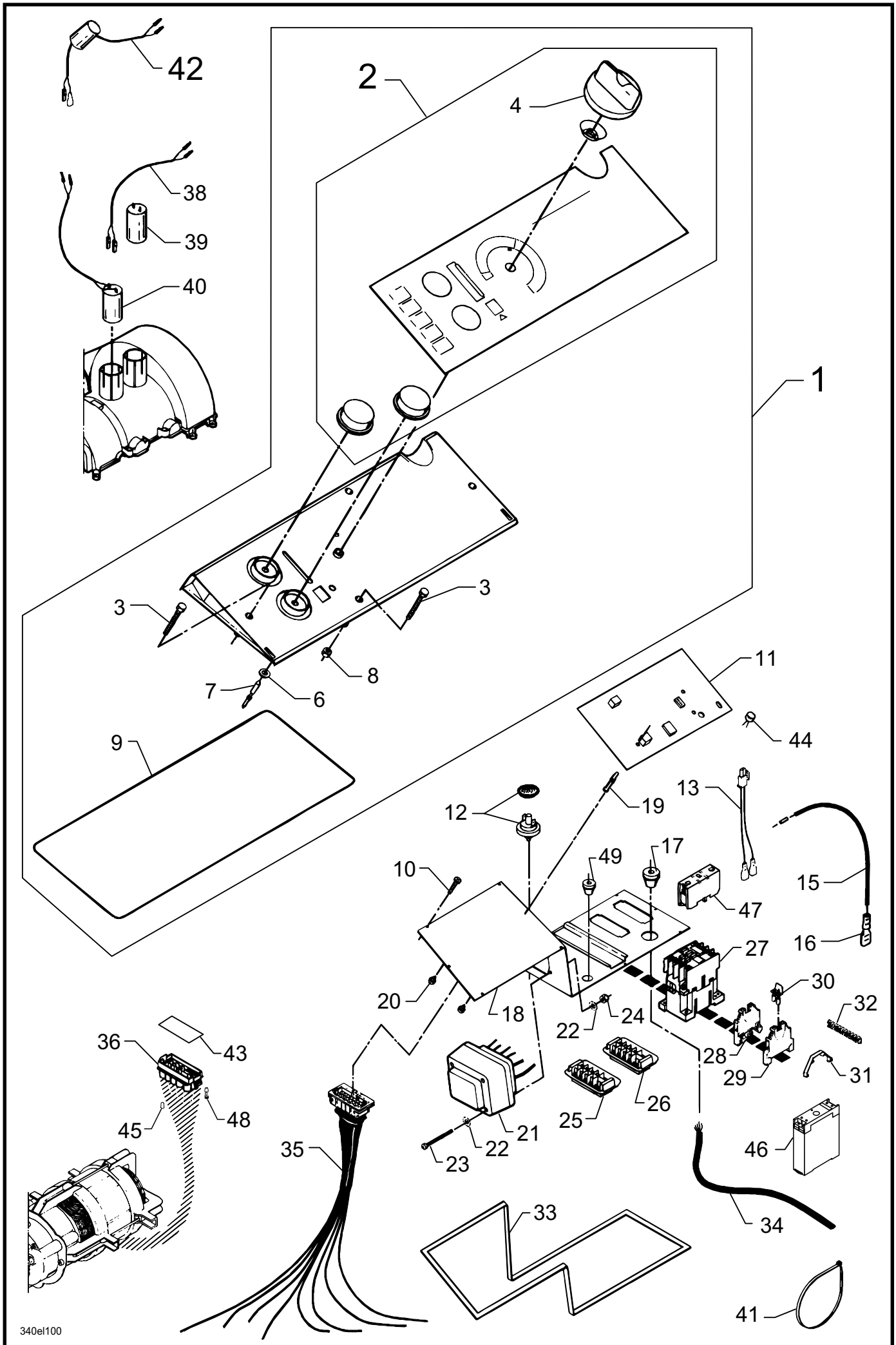

340el100

598 51 50 - 00.07

Pos. Ref.	Nr. No.	Betegnelse Bezeichnung	Designation Désignation	0840H/HA	1640H/HA	1840H/HA	3040H/HA	3840HA	MASTER
2	-	El-dele Electrical components Elektrische Komponenten Éléments électriques		x	x	x	x	x	
1	-	Sæt, instrumentpanel - ALTO Kit, control panel Satz, Armaturenbrett Kit, tableau de commande							
-	1119424	0840H		H					
-	1119425	0840HA		HA					
-	1119426	1640H			H				
-	1119427	1640HA			HA				
-	1119428	1840H				H			
-	1119429	1840HA				HA			
-	1119640	1440H, IRL	⇒01.10.98	H					
-	1119430	2340HA	USA/CDN						
-	1119431	3040H					H		
-	1119432	3040HA					HA		
-	1119473	u. damptrin - w/h heating stage o. Dampfstufe - sans étage vapeur							
-	1119433	3840HA						HA	
-	1119472	40HA MASTER							HA
2	-	Rep.sæt, greb/label - ALTO Kit, switches/label Satz, Schalteren/Aufkleber Kit, poignées/autocollant							
-	1119434	0840H		H					
-	1119435	0840HA		HA					
-	1119436	1640H			H				
-	1119437	1640HA			HA				
-	1119438	1840H				H			
-	1119439	1840HA				HA			
-	1119641	1440H, IRL	⇒01.10.98	H					
-	1119440	2340HA	USA/CDN						
-	1119441	3040H					H		
-	1119442	3040HA					HA		
-	1119474	u. damptrin - w/h heating stage o. Dampfstufe - sans étage vapeur							
-	1119443	3840HA						HA	
-	1119460	40HA MASTER							HA
3	1813666	Skrue Screw Schraube Vis	M5x45	4	4	4	4	4	4
4	6180920	Temperaturknop Temperature button Temperaturgriff Manette de température		1	1	1	1	1	1
6	1813682	Skive, aluminium Washer, aluminium Scheibe, Aluminium Rondelle, aluminium		1	1	1	1	1	1
7	6184104	Aksel Shaft Welle Abre		1	1	1	1	1	1
8	1813195	Møtrik Nut Mutter Ecrou		4	4	4	4	4	4
9	6184110	Pakning Gasket Dichtung Joint		1	1	1	1	1	1
10	1813989	Skrue Screw Schraube Vis	35x16 RF	12	12	12	12	12	12
11	6420030	Elektronisk styring El. control circuit board El. Steuerungseinheit Unité de commande électr.	40H	H	H	H	H		
-	6420031	40HA	⇒ 97.30	HA	HA	HA	HA		
-	6420032	3840HA	⇒ 97.30					HA	
-	6420033	40HA	97.31 ⇒	HA	HA	HA	HA		
-	6420034	3840HA, MASTER	97.31 ⇒					HA	HA

Pos. Ref.	Nr. No.	Betegnelse Bezeichnung	Designation Désignation	0840H/HA	1640H/HA	1840H/HA	3040H/HA	3840HA	MASTER
12	3820354	Fasefølge pressostat Phase seq. press. switch Phasenfolge Druckschalter Pressostat d'ordre des phases				1	1	1	1
-	4601147	Prop Plug Stöpsel Bouchon	1~	1	1				
13	6184876	Ledning for pressostat Cable for pressure switch Leitung für Druckschalter Câble pour pressostat				1	1	1	1
15	-	Ledning, sort Cable, black Leitung, schwarz Câble, noir	1x2,5 / H07V-K	x	x	x	x	x	x
15	-	Ledning, grøn Cable, green Leitung, Grün Câble, gris	TEW 105°C AWG 14 CDN	x	x	x	x		
16	3820941	Kabelsko Thimble of cable Kabelschuh Cousse de câble		x	x	x	x	x	x
17	-	Pakdåse Cable grommet Stopfbuchse Presse-étoupe		1	1	1	1	1	1
-	3803780	TET 10-14		1	1	1	1	1	1
-	3803798	(110/115V) TET 14-20	CDN	1					
-	3803798	(110/115V) TET 14-20	USA, CDN				1		
18	6184875	El-konsol Mounting plate Verbindungsplatte Plaque électrique		1	1	1	1	1	1
18	6184879	El-konsol Mounting plate Verbindungsplatte Plaque électrique	Δ/Y					1	1
19	3820347	Stag Tie rod Abstandsstange Tirant		1	1	1	1	1	1
20	1813740	Skrue Screw Schraube Vis	35x10	3	3	3	3	3	3
21	-	Styrettransformer Control transformer Steuerungstransformator Transformateur commande							
-	6184828	380V							
-	6184829	200V							
-	6184830	220V							
-	6184831	240V							
-	6184832	110V (115V)							
-	6184833	415V-50/60Hz							
-	6184834	415/440V							
-	6184835	220/380V							
-	6184836	220/440V							
-	6184837	100V-50/60Hz	GB						
22	1801281	Skive Washer Scheibe Rondelle	M3	8	8	8	8	8	8
23	1813856	Skrue Screw Schraube Vis	3x45	4	4	4	4	4	4
24	1800168	Møtrik Nut Mutter Ecrou	M3	4	4	4	4	4	4
25	3820214	Motorstik, (han) sort Motor plug, (male) black Motorstecker, (außen) schwarz Fiche de commutation, (mâle) noir	Y						

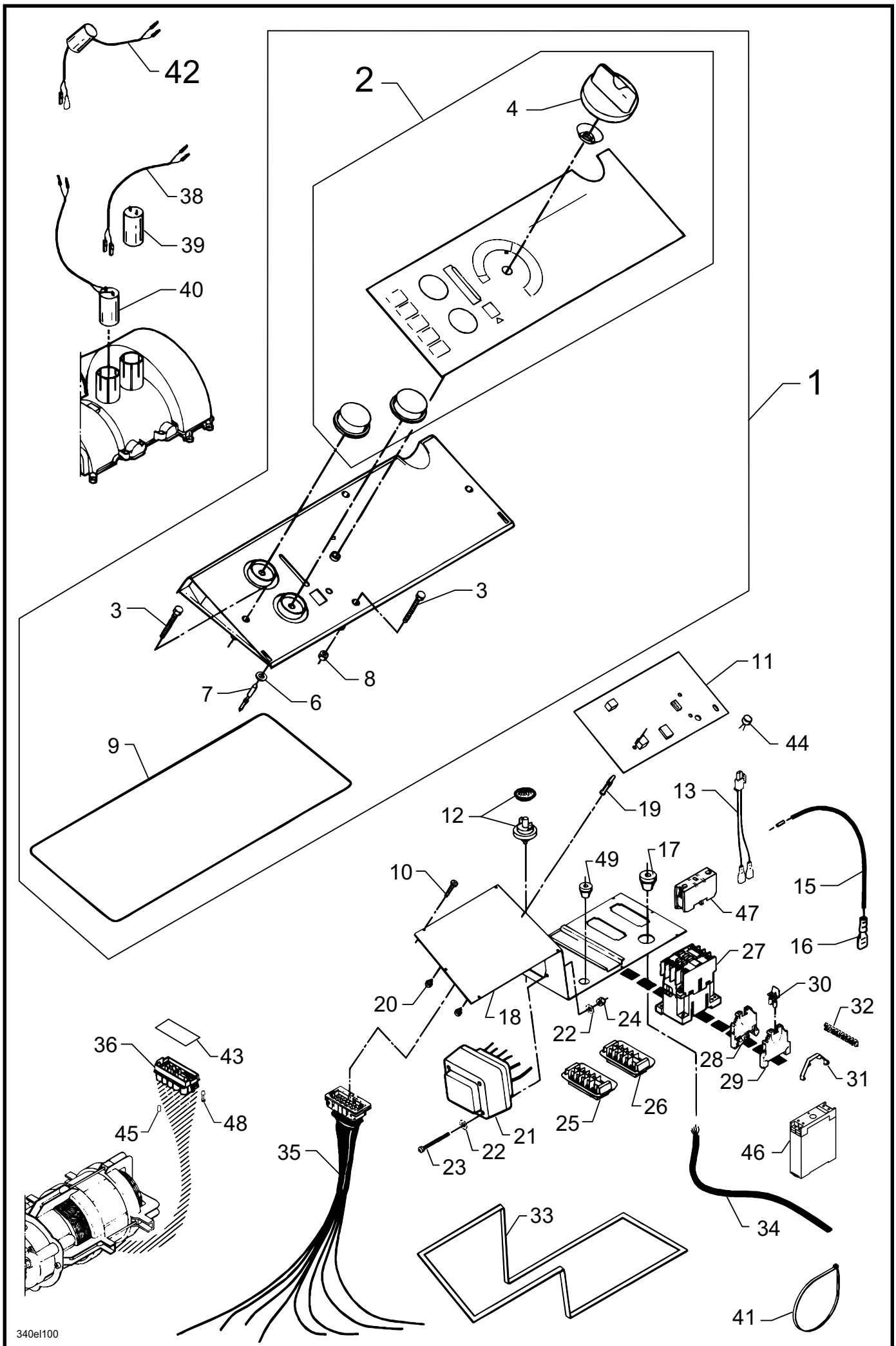

340el100

598 51 50 - 00.07

Pos. Ref.	Nr. No.	Betegnels Bezeichnung	Designation Désignation	0840/H/A	1640/H/A	1840/H/A	3040/H/A	3840/H/A	MASTER
25	3820206	Motorstik, (han) grå Motor plug, (male) grey Motorstecker, (außen) grau Fiche de commutation, (mâle) gris	Δ						
26	3821022	Omkoblingsstik (han) blå Change over plug, (male) Umschaltstecker, (außen) blau Fiche de commutation, (mâle) bleu	B-E-I-N						
26	3821445	Stjernekobling (gul) Star connection (yellow) Sternschaltung (gelb) Étoile-commutation (jaune)	B-E-I-N						
27	-	Kontaktor Contactor Schütz Contacteur	24V						
-	3804051	CA3 - 16 - 10							
-	3804168	CA3 - 23 - 10	⇒ 31.12.99						
-	3821739	23A 24V 50-60Hz	01.01.00 ⇒						
-	3804234	CA3 - 30 - 10							
28	3807518	Rækkeklæmme Terminal clip Klemme Rangée de bornes							
-	3807518			7	7	7	7	7	7
-	3821515		(2340HA)				(7)		
-	3821030		B, E, I, N			4	4	4	4
-	3821048	Endeplade End stop Endverschuß Support arrière	B, E, I, N			2	2	2	2
29	3817483	Rækkeklæmme, jord Terminal clip, earth Klemme, Erde Rangée de bornes, terre							
29	3821513	Rækkeklæmme, jord Terminal clip, earth Klemme, Erde Rangée de bornes, terre	(2340HA)						
30	3807534	Topolet laske Bipolar short circuit bridge Zweipolig Lasche Plaque - bipolaire							
-	3800331	Trepollet laske Three-poled short circuit bridge Dreipolig Lasche Plaque - tripolaire							
31	3807542	Afdækning Cover Abdeckung Couverture		4	4	4	4	4	4
32	-	Komponentafmærkning Component marking Komponenten markierung Marque des composants							
-	3820362	3P [$\frac{1}{\Delta}$ 1 L3 L2 L1 2 3]							
-	3820370	3P Y/ Δ [$\frac{1}{\Delta}$ L3 L2 L1 1 2 3 4 5]							
-	3820388	1P [$\frac{1}{\Delta}$ 1 N P 2 3]							
33	6184733	Pakning Gasket Dichtung Joint		1	1	1	1	1	1
34	-	El-kabel El. cable Anschlusskabel Câble électrique							
-	6180260	H07RN-F 4G 1.5 DK, S, NL, F, D, CH, A, U, B, I, E, N, SF (3x380V 50Hz) GB, U, SGP, AUS			x	x	x	x	
-	6180261	H07RN-F 3G 1.5 D, A, B, E, F, I, N, NL, F GB, SGP, AUS (1x240V 50Hz) U (1x220V 60Hz) - SF (1x220V 50Hz)			x				
-	6180262	H07RN-F 3G 2.5			x	x			
-	6180268	H07RN-F 3G 4							
-	6180269	H07RN-F 3G 2.5	GB Y/Δ					x	x

Pos. Ref.	Nr. No.	Betegnels Bezeichnung	Designation Désignation	0840/H/A	1640/H/A	1840/H/A	3040/H/A	3840/H/A	MASTER
-	3821316	SOW-AWG 20A w/ GFCI	USA	x					
-	3821142	(1x115V 60Hz) SOW-AWG 14/3 w/ GFCI	USA			x			
-	6180263	SOW-AWG 12/3 (1x115V 60Hz)	CDN	x					
-	6180264	SOW-AWG 14/3 (1x220V 60Hz)	CDN			x			
-	6180265	SOW-AWG 14/4 (3x220V, 3x415-440V 60Hz)						x	
-	6180266	SVCT4G2.0	J					x	
-	3821014	SOW-AWG w/ GFCI	(2340HA)						
-	6180239	SOW-AWG	(2340HA)						
35	6185845	Styrekabler m. stik Control wires w. connectors		1	1	1	1	1	1
-	6184825	Steuerungskabeln m. Steckern Câble direction ⇒	26.10.95	1	1	1	1	1	1
36	3820230	Motorstik (hun) Motor plug (female) Motorstecker (innen) Fiche moteur (femelle)							
38	6180273	Kondensatorledning Capacitor wire	1.6 - 1.8 50Hz		x	x			
-	6180275	Kondensatorleitung Câble de condensateur	0.8 - 1.8 60Hz	x		x			
39	-	Kondensator (start) Capacitor (start-up) Kondensator (Start) Condensateur (marche)							
-	3821063	160-200 µF	(2340HA)		x	x			
-	3821139	200-250 µF			x	x			
-	3821216	315-350 µF		x	x				
40	-	Kondensator (drift) Capacitor (operation) Kondensator (Betrieb) Condensateur (fonction.)							
-	3821427	1~, 60Hz	40 µF		x	x			
-	3821426	1~, 60Hz	USA, CDN 100 µF	x					
41	1814052	Kabelbinder Cable clip Kabelhalter Support pour câble	L = 150 mm	2	2	2	2		
42	1119612	Rep.sæt, kondensatorledning Kit, capacitor wire, 1~ 60Hz Rep. satz, Kondensatorleitung kit de rép., câble de condensateur	USA, CDN						
43	3821456	Pakning for motorstik Gasket f. motor plug Dichtung f. Motorstecker Joint p. Fiche de commutation		1	1	1	1		
44	3821255	Sikring Fuse 2AT Sicherung Fusible		1	1	1	1		
45	3820909	Blændprop Plug Pfropfen Manchon			3	3			
46	3821482	Timer Timer Zeitschalter Rupteur						1	1
47	3821509	Hjælpekontakt Auxiliary switch Zusatzschalter Bouton auxiliaire	1~	1	1	(1)			
48	1119375	Powertimer stik (25 stk.) Powertimer plug (25 pcs.) Powertimerstecker (25 Stck.) Fiche Powertimer (25 pcs.)							
49	3803764	Pakdåse Cable grommet Stopfbuchse Presse-étoupe	TET5-7C	1	1	1	1	1	1

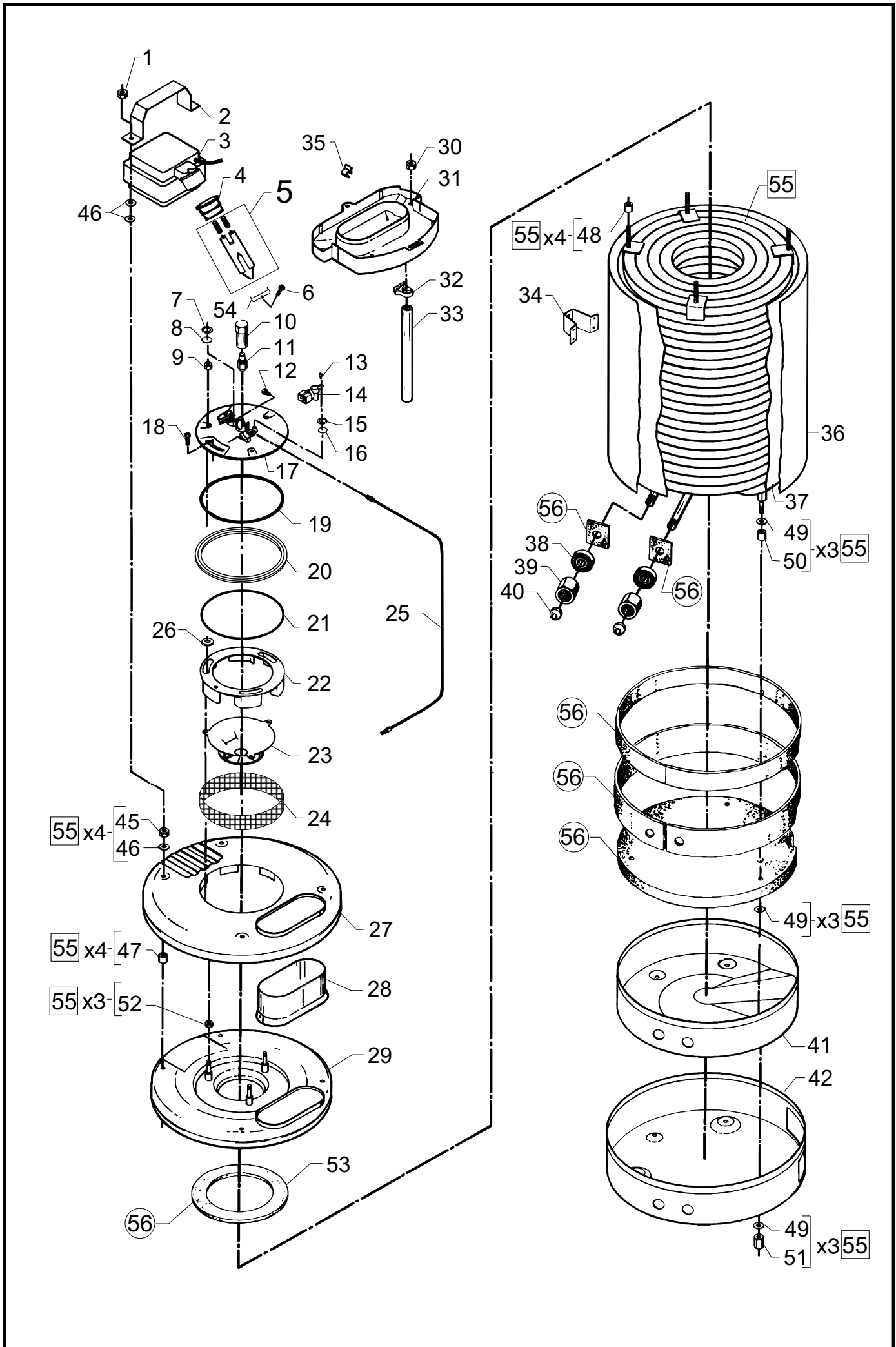

598 51 50 - 00.07

Pos. Ref.	Nr. No.	Betegnels Bezeichnung	Designation Désignation	08/01/H/A	16/01/H/A	18/01/H/A	30/01/H/A	38/01/H/A	MASTER
3	-	Kedel Boiler Kessel Chaudière							
1	1803725	Møtrik Nut Mutter Ecrou	M8	2	2	2	2	2	2
2	6184290	Beslag Fittings Beschlag Fixation		1	1	1	1	1	1
3	-	Tændtransformer Ignition transformer Zündtransformator Transformateur d'allumage	10kW	1	1	1	1	1	1
-	6184840	380V, 50-60Hz							
-	6184841	200V, 50-60Hz							
-	6184842	220V, 50-60Hz							
-	6184843	240V, 50Hz							
-	6184839	110-115V, 50-60Hz	CDN 0.8	x					
-	6184838	230V, 60Hz	USA 1.8/3.0		x	x			
-	6184848	110-115V, 50-60Hz	USA 0.8	x					
-	6184847	220V, 60Hz	USA 1.8		x				
-	6184845	415V, 50-60Hz							
-	6184846	440V, 50-60Hz							
-	6185840	Alle, all, alle, toutes						x	x
4	6184729	Tylle Cap Kappe Capuchon		1	1	1	1	1	1
5	6184359	Elektrodeholder, komplet Holder for electrode, compl. Halter f. Elektrode, kompl. Support p. électrode, compl.		1	1	1	1		
-	6186362							1	1
6	1805464	Skrue for elektroder Screw for electrodes Schraube für Elektroden Vis pour électrode	M4x16	1	1	1	1	1	1
7	1814611	Seegerring Circlip Seegerring Anneau		1	1	1	1	1	1
8	6184295	Inspektionsglas Inspection glass Inspektionsglas Oeil de controle		1	1	1	1	1	1
9	1802743	Møtrik Nut Mutter Ecrou	M5	3	3	3	3	3	3
10	6184400	Dyseholder Holder f. nozzle Düsensitz Support du gicleur		1	1	1	1		
-	6184412							1	1
11	2802445	Oliedyse Oil nozzle, (4.0) Brennstoffdüse Gicleur			1	1	1		
-	2802719							1	1
-	2802649	(5.17)	CDN 1.8 - 3.0		1	1			
-	2802647	(3.6)	CDN 0.8	1					
-	2802690	(3.6)	USA 0.81	1					
12	1803717	Skrue for dyse Screw for nozzle Schraube für Düse Vis pour buse	4x6	1	1	1	1	1	1
13	1800606	Skrue Screw Schraube Vis	M4x10	1	1	1	1	1	1
14	6420300	Flammeføler, komplet Flame sensor, complete Fühler f. Flammenüberwachung Sonde - contrôle flammes		1	1	1	1	1	1
15	1814584	Seegerring Seeger circlip ring SeegerRing Anneau Seeger						1	1

Pos. Ref.	Nr. No.	Betegnels Bezeichnung	Designation Désignation	08/01/H/A	16/01/H/A	18/01/H/A	30/01/H/A	38/01/H/A	MASTER
16	6220285	Glas Glass Glas Controlle							1 1
17	6184272	Kedeldæksel Boiler cover Kesseldeckel Couvercle de bruleur		1	1	1	1		
-	6186377							1	1
18	1813575	Skrue Screw Schraube Vis	M5x12 M5x16	1	1	1	1		
-	1814516							1	1
19	6184296	Pakning Gasket Dichtung Joint		1	1	1	1	1	1
20	6184318	Ring f. kedeldæksel Ring f. boiler cover Ring f. Kesseldeckel Anneau p. couvercle de bruleur							1 1
21	6184319	Pakning Gasket Dichtung Joint							1 1
22	6184255	Luftspjæld Air throttle Luftscheiber Régulateur d'air		1	1	1	1	1	1
23	6184350	Luftfordeler Air distributor Luftverteiler Distributeur d'air		1	1	1	1		
-	6186361								1 1
24	6184322	Luftfilter Air filter Luftfilter Filtre à air							1 1
25	6184450	Olierør, komplet Oil pipe, complete Ölrohr, kompl Tube à fuel, compl.		1	1	1	1	1	1
26	1807999	Skive Washer Scheibe Rondelle		3	3	3			
27	6184281	Kedeltop, udvendig Boilertop, outer section Oberes Kesselteil, Außen Capot de chaudière, extérieure		1	1	1	1	1	1
28	6184259	Skorsten Chimney Schornstein Cheminée		1	1	1	1	1	1
29	6184360	Kedeltop, indvendig Boilertop, inner section Oberes Kesselteil, Innen Capot de chaudière, intérieure		1	1	1	1		
-	6186360								1 1
30	1803725	Møtrik Nut Mutter Ecrou		2	2	2	2	2	2
31	6184303	Vandskjold Water shield Wasserchutzschirm Jupon d'eau		1	1	1	1	1	1
32	1813658	Spændebånd Hose Clip Schlauchschelle Collier de serrage	ø17-20	1	1	1	1	1	1
33	2450009	Slange Hose Schlauch Tuyau	1/2"	1	1	1	1	1	1
34	6184286	Støttebeslag (for tank) Fitting Beschlag Patte fixation		1	1	1	1	1	1
35	3821105	Kabelholder Cable clip Kabelhalter Support câble		1	1	1	1	1	1

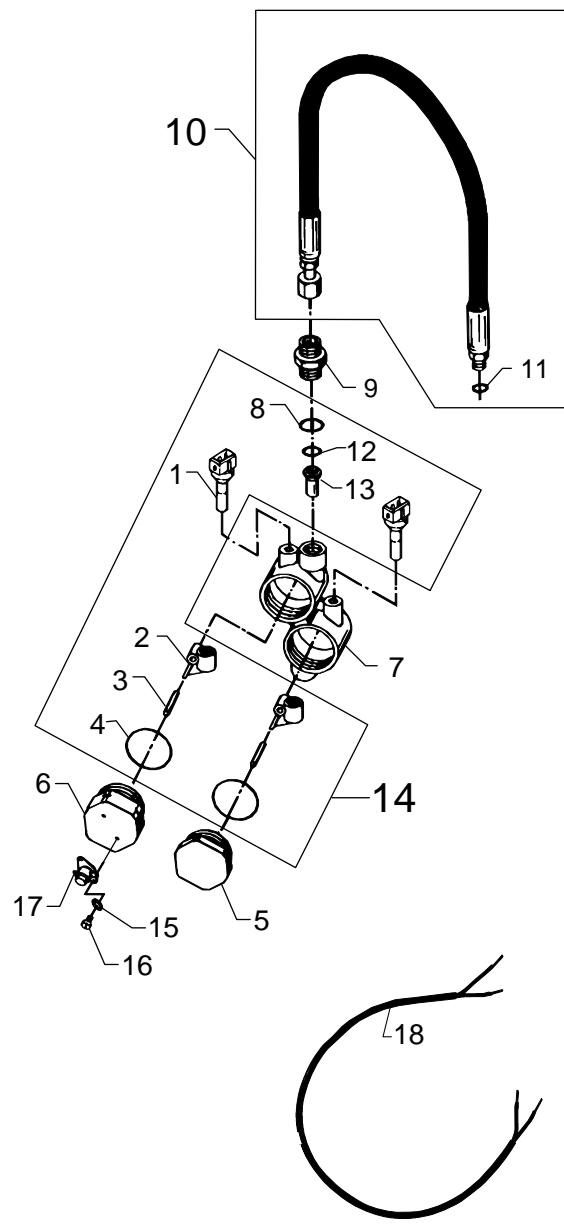
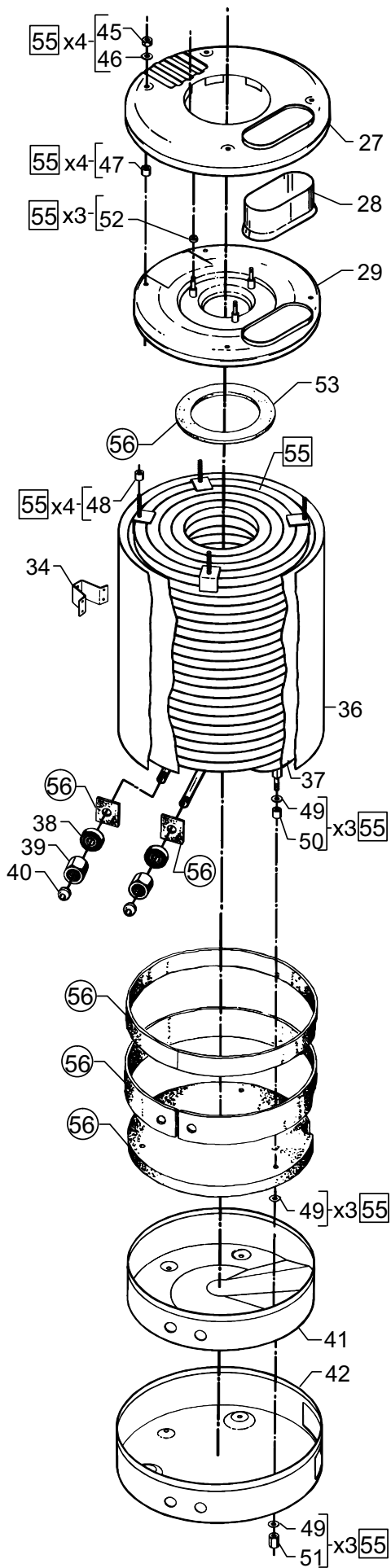

Pos. Ref.	Nr. No.	Betegnels Bezeichnung	Designation Désignation	0840/H/A	1640/H/A	1840/H/A	3040/H/A	3840/H/A	MASTER
36	6184262	Kedelsvøb, udvendig Boiler jacket, outer Außenmantel f. Kessel Jupe externe		1	1	1	1	1	1
37	6185927	Kedelsvøb, indvendig Boiler jacket, inner Innenmantel f. Kessel Jupe interne		1	1	1	1	1	1
38	6184282	Rørgennemføring (gummipakning) Rubber lead-in Gummidichtung Support de caoutchouc		2	2	2	2	2	2
39	6184288	Omløber Union nut Überwurfmutter Ecrou		2	2	2	2	2	2
40	6184287	Nippel Nipple Nippel Raccord		2	2	2	2	2	2
41	6184250	Kedelbund, indvendig Boiler buttom, inner Kessel-unterteil, Innen- Fond de chaudière, intérieure		1	1	1	1	1	1
42	6184254	Kedelbund, udvendig Boiler buttom, outer Kessel-unterteil, Außen- Fond de chaudière, extérieure		1	1	1	1	1	1
45	1803725	Møtrik Nut Mutter Ecrou	M8	4	4	4	4	4	4
46	1800796	Skive Washer Scheibe Rondelle	M8	8	8	8	8	8	8
47	6184275	Bøsning Bush Buchse Baque		4	4	4	4	4	4
48	6184293	Bøsning Bush Buchse Baque		4	4	4	4	4	4
49	1813567	Skive Washer Scheibe Rondelle		9	9	9	9	9	9
50	6184275	Bøsning Bush Buchse Baque		3	3	3	3	3	3
51	6184276	Møtrik Nut Mutter Ecrou		3	3	3	3	3	3
52	6184294	Bøsning Bush Buchse Baque		3	3	3	3		
53	1119700	Spiralpakning Coil gasket Heizschlangedichtung Joint p. serpentin		1	1	1	1	1	1
54	6184328	Bøjle for elektrodeholder Clamp for electrode holder Bügel für Elektrodenhalter Pince pour support électrode		1	1	1	1	1	1
55	6184931	Kedelspiral m. møtrikker Boiler coil with nuts Heizschlange mit Muttern Chaudière avec écrous		x	x	x	x		
-	6184946							x	x
55	6185929	Kedelspiral m. møtrikker, RF Boiler coil with nuts, SS Heizschlange mit Muttern, RF Chaudière avec écrous, INOX		x	x	x	x		
-	6185928							x	x
56	1119236	Isoleringssæt Insulation kit Satz für Isolation Kit de isolant		1	1	1	1	1	1

Pos. Ref.	Nr. No.	Betegnels Bezeichnung	Designation Désignation	0840/H/A	1640/H/A	1840/H/A	3040/H/A	3840/H/A	MASTER
4	-	Strømningskontakt Flow switch Strömungsschalter Circulation sélecteur		x	x	x	x	x	x
1	6420302	Reedkontakt m. O-ring Reed switch with O-ring Reedschalter mit O-ring Reed sélecteur avec joint torique		2	2	2	2	2	2
2	6184927	Svingarm m. magnet, sæt N-S Swing arms w. magnet, kit N-S Pendelarm m. Magnet, Satz N-S Levier a. aimant, kit N-S		1	1	1	1	1	1
3	6184923	Aksel Shaft Welle Axe		2	2	2	2	2	2
4	3001716	O-ring O-ring O-Ring Joint torique		2	2	2	2	2	2
5	6184802	Dæksel, tyndt Plug, thin Verschlusschraube, dünn Bouchon, mince		1	1	1	1	1	1
6	6184801	Dæksel, tyk Plug, thick Verschlusschraube, dick Bouchon, gros		1	1	1	1	1	1
7	6184534	Indikatorhus Housing Gehäuse Carter		1	1	1	1	1	1
8	3000064	O-ring O-ring O-Ring Joint torique		1	1	1	1	1	1
9	1601079	Forskruing Threaded connection Verschraubung Raccord		1	1	1	1	1	1
10	1450000	Intern højtryksslange med O-ring Internal h. p. hose with O-ring Interner H.d. Schlauch + O-Ring Tuyau h. p., int. a. joint torique		x	x	x	x	x	x
11	3000072	O-ring O-ring O-Ring Joint torique		1	1	1	1	1	1
12	3001799	O-ring O-ring O-Ring Joint torique	HA	1	1	1	1	1	1
13	6401821	Dyse Nozzle Düse Buse	HA	1	1	1	1	1	1
14	1119311	Rep.sæt, strømningskontakt Rep. kit, flow switch Rep. Satz, Strömungsschalter Kit, circulation sélecteur	H & HA	x	x	x	x	x	x
15	1809953	Stjerneskrive, HA Washer Scheibe Rondelle	97.31 ⇒	2	2	2	2	2	2
16	1803139	Maskinskrue, HA Screw Schraube Vis	97.31 ⇒	2	2	2	2	2	2
17	3821228	Termoafbryder, HA Thermal switch Thermoschalter Interrupteur thermique	97.31 ⇒	1	1	1	1	1	1
18	6185931	Kabel, HA Cable Kabel Câble	97.31 ⇒	1	1	1	1	1	1

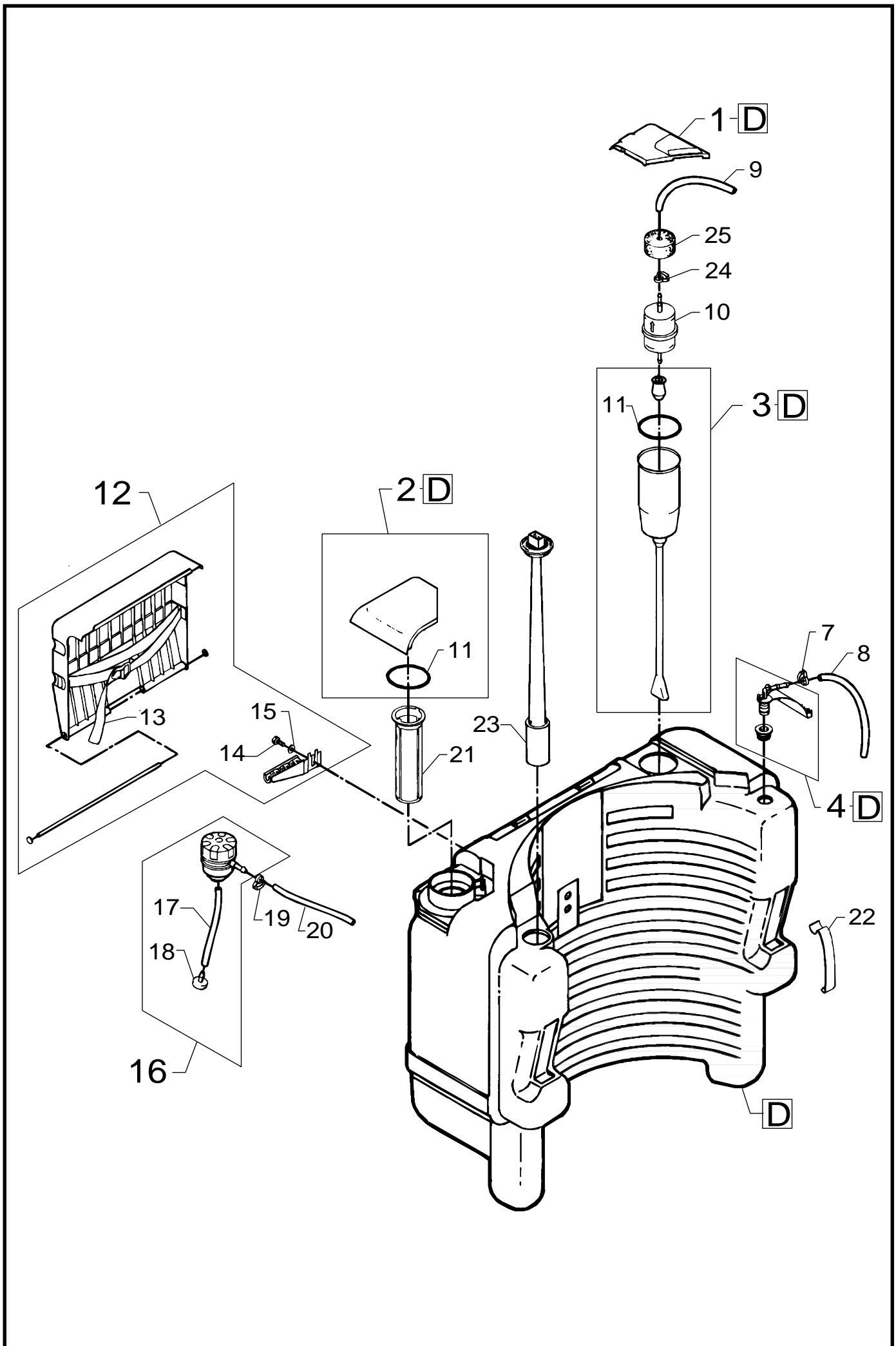

Pos. Ref.	Nr. No.	Betegnelse Bezeichnung	Designation Désignation	0840/H/A	1640/H/A	1840/H/A	3040/H/A	3840/H/A	MASTER
5	-	Brændstoftank Fuel tank Brennstofftank Réservoir du fuel							
D	6184932	Brændstoftank, sæt Fuel tank, kit Brennstofftank, Satz Réservoir du fuel, kit		x	x	x	x	x	x
D	6184944	Brændstoftank, sæt Fuel tank, kit Brennstofftank, Satz Réservoir du fuel, kit	CDN	x	x	x	x		
1	6184097	Filterdæksel Cover for filter Deckel für Filter Couvercle du filtre		1	1	1	1	1	1
2	1119237	Rep.sæt, Låg for brændstoftank Rep. kit, Cover for fuel tank Satz, Deckel für Brennstofftank Kit, Couvercle du réservoir fuel		x	x	x	x	x	x
2	1119271	Rep.sæt, Låg for brændstoftank Rep. kit, Cover for fuel tank Satz, Deckel für Brennstofftank Kit, Couvercle du réservoir fuel	CDN	x	x	x	x		
3	1119238	Rep.sæt, Filterophæng Rep. kit, Filter holder Rep.satz, Filterhalterung Kit de rép., Plongeur filt. (fuel)		x	x	x	x	x	x
4	1119239	Rep.sæt, Returdæksel Rep. kit, Return lid Rep.satz, Rückführungsdeckel Kit de rép., Retur fuel		1	1	1	1	1	1
7	6184101	Slangeklemme Hose clip Schlauchschelle Collier de serrage		1	1	1	1	1	1
8	2450007	Olieslange Fuel hose Brennstoffschlauch Tuyau à fuel	950mm	1	1	1	1	1	1
9	2450006	Olieslange Fuel hose Brennstoffschlauch Tuyau à fuel	1200mm	1	1	1	1	1	1
10	6184100	Oliefilter Fuelfilter Brennstofffilter Filtre à fuel		1	1	1	1	1	1
11	3003944	O-ring O-ring O-Ring Joint torique		2	2	2	2	2	2
12	1119240	Rep.sæt, Dunkholder Rep. kit, Container rack Rep.satz, Behältergestell Kit de rép., Capot receptacle		x	x	x	x	x	x
13	6184902	Dunksele Strap for container Reimen f. Behälter Sangle p. bidon		1	1	1	1	1	1
14	1802933	Skrue Screw Schraube Vis	M6x22 RF	1	1	1	1	1	1
15	1813807	Skive Washer Scheibe Rondelle		1	1	1	1	1	1
16	6180425	Doseringsenhed, komplet Dosing unit, complete Dosierungseinheit. kompl. Unité de dosage		x	x	x	x	x	x
17	2450002	Slange Hose Schlauch Tuyau		1	1	1	1	1	1
18	6400240	Filter Filter Filter Filtre		1	1	1	1	1	1

Pos. Ref.	Nr. No.	Betegnelse Bezeichnung	Designation Désignation	0840/H/A	1640/H/A	1840/H/A	3040/H/A	3840/H/A	MASTER
19	1810084	Slangeklemme Hose clip Schlauchschelle Collier de serrage		1	1	1	1	1	1
20	2450011	Slange Hose Schlauch Tuyau		1	1	1	1	1	1
21	1604222	Filtersi Strainer Filter Filtre		1	1	1	1	1	1
22	2601565	Fjederclips Hook Federschoß Ressort de fixation		2	2	2	2	2	2
23	6420303	Niveauføler, komplet Level switch, compl. Niveaukontakt, kompl. Niveau contact, compl.		1	1	1	1	1	1
24	1810084	Spændebånd Hose clip Schlauchschelle Collier de serrage		1	1	1	1	1	1
25	6184117	Skumgummiprop Foam rubber stopper Schaumstoffkorken Bouchon caoutchouc		1	1	1	1	1	1

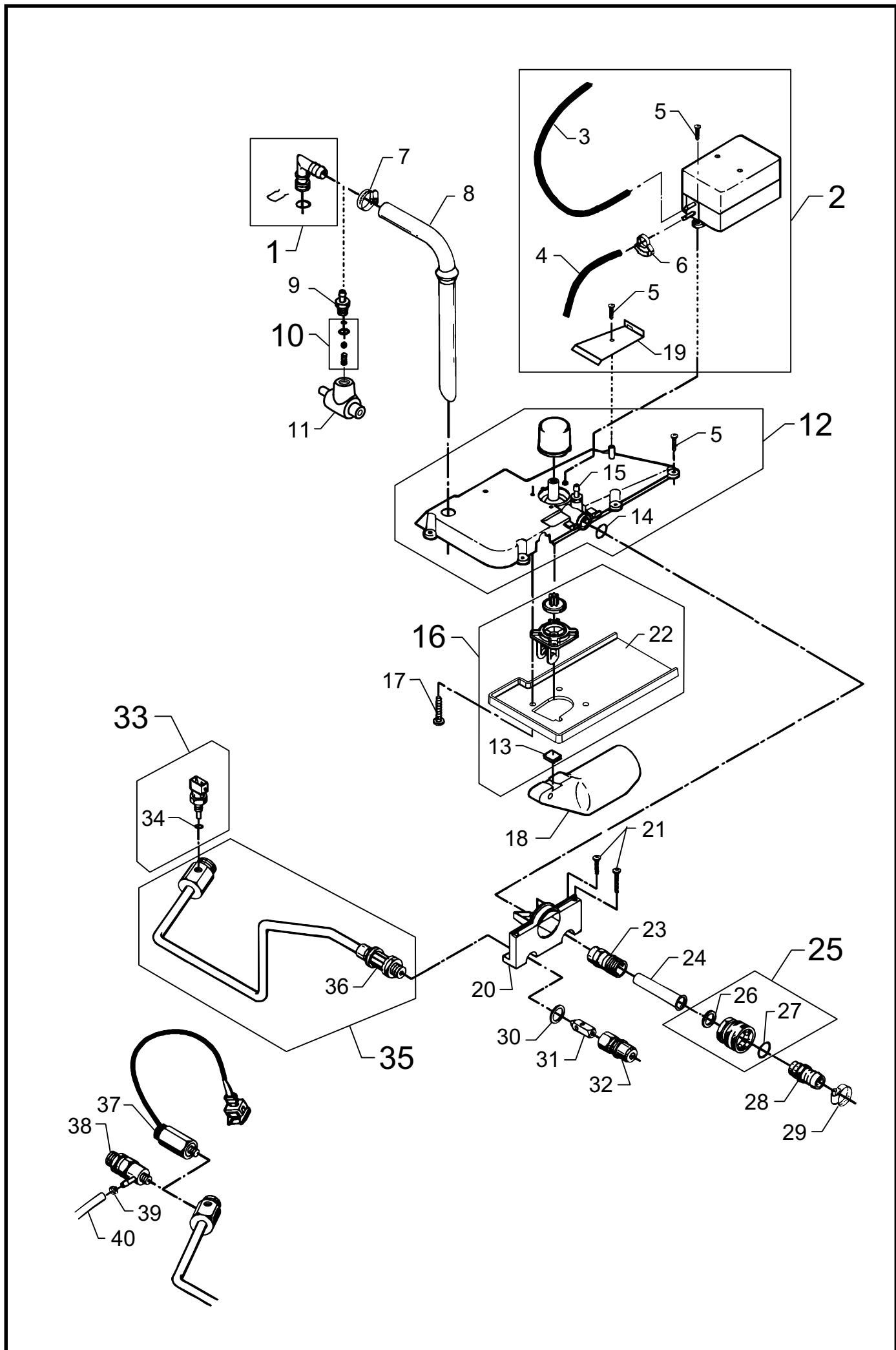

Pos. Ref.	Nr. No.	Betegnels Bezeichnung	Designation Désignation	0840/H/A	1640/H/A	1840/H/A	3040/H/A	3840/H/A	MASTER
6	-	Svømmerhuslåg Cover f. float chamber Deckel f. Schwimmergehäuse Couvercle p. bac à flotteur		x	x	x	x	x	x
1	1119210	Rep.sæt, tilgangsvinkel Rep. kit, inlet elbow Rep.satz, Einlaßwinkel Kit de rép., coude du entrée		x	x	x	x	x	x
2	1119695	Rep.sæt, „No Scale“ pumpe Rep. kit, „No Scale“ pump Rep.satz, „No Scale“ Pumpe Kit de rép, pompe de „No Scale“		x	x	x	x	x	x
3	2450003	Slange Hose, 400mm Schlauch Tuyau		1	1	1	1	1	1
4	2406423	Slange Hose, 180mm Schlauch Tuyau	26.10.95 =>	1	1	1	1	1	1
5	1813989	Skrue Screw Schraube Vis	35x16 RF	7	7	7	7	7	7
6	1814151	Slangeklemme Hose clip Schlauchschelle Collier de serrage	Ø7.8/8.7	2	2	2	2	2	2
7	1805100	Spændebånd Hose clip Schlauchschelle Collier de serrage	Ø8-22 GLV	1	1	1	1	1	1
8	6184588	Sugerør, tilgang Suction tube, inlet Saugrohr, Einlaß Tube d'aspiration, entrée		1	1	1	1		
-	6184590	Sugerør, tilgang Suction tube, inlet Saugrohr, Einlaß Tube d'aspiration, entrée						1	1
9	3400512	Slangestuds Hose tail Schlauchstutzen Raccord de tuyau						1	1
10	1119694	Rep. sæt for kemiinjektor Rep. kit for chemical injector Rep. satz, für Chemikalieninjektor Kit de rép. pour injecteur chemie						1	1
11	6184677	Hus Housing Gehäuse Carter						1	1
12	1119242	Rep.sæt, svømmerhuslåg Rep. kit, float chamber cover Satz, Schwimmergehäusedeckel Kit de couvercle (bac à flotteur)	H	x	x	x	x		
-	1119249	Rep.sæt, svømmerhuslåg Rep. kit, float chamber cover Satz, Schwimmergehäusedeckel Kit de couvercle (bac à flotteur)	HA	x	x	x	x	x	x
13	6184581	Ventilsæde for svømmer Valve seat Ventilsitz Siège de soupape		1	1	1	1	1	1
14	3004221	O-ring O-ring O-Ring Joint torique		1	1	1	1	1	1
15	6401820	Slangestuds Hose tail Schlauchstutzen Raccord de tuyau	HA	1	1	1	1	1	1
16	1119243	Rep.sæt, svømmerventil Rep. kit, float valve Rep.satz, Schwämmerventil Kit de rép, flotteur (clapet)		x	x	x	x	x	x
17	1813641	Skrue Screw Schraube Vis	40x16 RF	4	4	4	4	4	4

Pos. Ref.	Nr. No.	Betegnels Bezeichnung	Designation Désignation	0840/H/A	1640/H/A	1840/H/A	3040/H/A	3840/H/A	MASTER
18	6184084	Svømmer Float Schwimmer Flotteur		1	1	1	1	1	1
19	6184679	Beslag for „No Scale“ pumpe Fitting for „No Scale“ pump Haltung für „No Scale“ Pumpe Garniture p. pompe de „No Scale“		1	1	1	1	1	1
20	6184086	Manometerkonsol Pressure gauge bracket Manometerdeckel Capot de manomètre		1	1	1	1	1	1
21	1813633	Skrue Screw Schraube Vis	35x25 RF	6	6	6	6	6	6
22	6184591	Ledeplade Guide plate Führungsplatte Plaque guide		1	1	1	1	1	1
23	6184583	Filterhus Housing f. filter Filtergehäuse Gaine de filtre d'eau		1	1	1	1	1	1
24	6100941	Filter Strainer Filter Filtre		1	1	1	1	1	1
25	1602945	Lynkobling, komplet Quick coupling, compl. Schnellkupplung, kompl. Coupleur rapide, compl.		x	x	x	x	x	x
26	3001237	Pakning Gasket Dichtung Joint		1	1	1	1	1	1
27	3000320	O-ring O-ring O-Ring Joint torique		1	1	1	1	1	1
28	1600659	Lynkoblingsnippel (lavtryk) Nipple f. quick coupling L.P. Nippel f. Schnellkupplung N.D. Entrée du coupleur rapide B.P.		1	1	1	1	1	1
-	1602473	Lynkoblingsnippel (lavtryk) Nipple f. quick coupling L.P. Nippel f. Schnellkupplung N.D. Entrée du coupleur rapide B.P.	CH						
-	1605955	Lynkoblingsnippel (lavtryk) Nipple f. quick coupling L.P. Nippel f. Schnellkupplung N.D. Entrée du coupleur rapide B.P.	USA CDN						
29	1802107	Spændebånd Hose clip Schlauchschelle Collier de serrage		1	1	1	1	1	1
30	1801075	Tætningsskive Tightening gasket Dichtungsscheibe Rondelle d'étanchéité		1	1	1	1	1	1
31	6101038	Stempel Piston Kolben Piston		1	1	1	1	1	1
32	1600493	Lynkoblingsnippel (højtryk) Nipple f. quick coupling H.P. Nippel f. Schnellkupplung H.D. Entrée du coupleur rapide H.P.		1	1	1	1	1	1
-	1603101	Lynkoblingsnippel, RF (højtryk) Nipple f. quick coupling, SS H.P. Nippel f. Schnellkupplung, RF H.D. Entrée du coupleur rapide, INOX		1	1	1	1	1	1

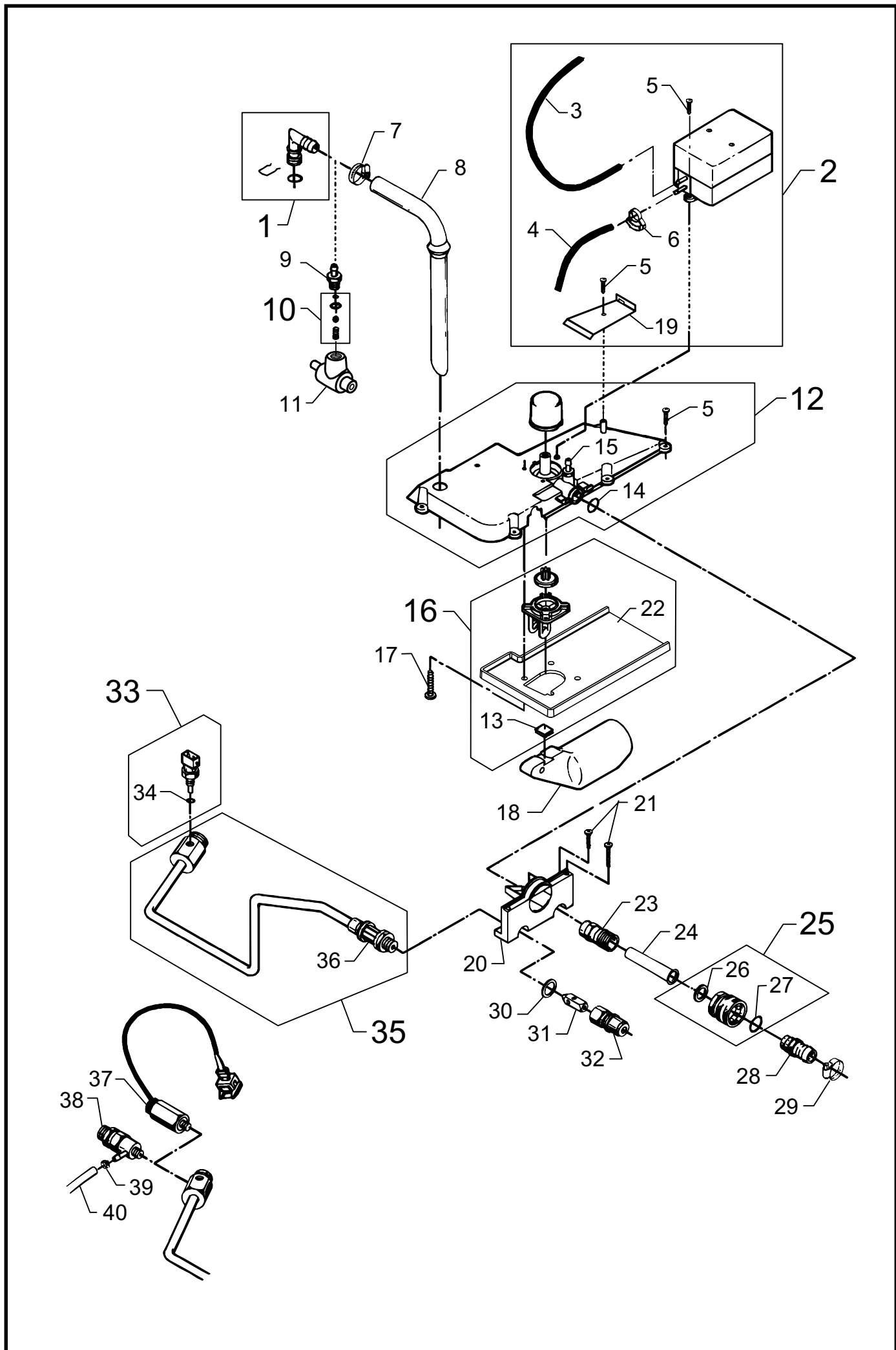

598 51 50 - 00.07

